

Programmable Controller

MELSEC iQ-R
series

MELSEC iQ-R Simple Motion Module User's Manual (Advanced Synchronous Control)

-RD77MS2
-RD77MS4
-RD77MS8
-RD77MS16



-RD77GF4
-RD77GF8
-RD77GF16
-RD77GF32



SAFETY PRECAUTIONS

(Read these precautions before using this product.)

Before using this product, please read this manual and the relevant manuals carefully and pay full attention to safety to handle the product correctly.

The precautions given in this manual are concerned with this product only. Refer to the MELSEC iQ-R Module Configuration Manual for a description of the PLC system safety precautions.

In this manual, the safety precautions are classified into two levels: "  WARNING" and "  CAUTION".

 WARNING	Indicates that incorrect handling may cause hazardous conditions, resulting in death or severe injury.
 CAUTION	Indicates that incorrect handling may cause hazardous conditions, resulting in minor or moderate injury or property damage.

Under some circumstances, failure to observe the precautions given under "  CAUTION" may lead to serious consequences.

Observe the precautions of both levels because they are important for personal and system safety.

Make sure that the end users read this manual and then keep the manual in a safe place for future reference.

[Design Precautions]

WARNING

- Configure safety circuits external to the programmable controller to ensure that the entire system operates safely even when a fault occurs in the external power supply or the programmable controller. Failure to do so may result in an accident due to an incorrect output or malfunction.
 - (1) Emergency stop circuits, protection circuits, and protective interlock circuits for conflicting operations (such as forward/reverse rotations or upper/lower limit positioning) must be configured external to the programmable controller.
 - (2) When the programmable controller detects an abnormal condition, it stops the operation and all outputs are:
 - Turned off if the overcurrent or overvoltage protection of the power supply module is activated.
 - Held or turned off according to the parameter setting if the self-diagnostic function of the CPU module detects an error such as a watchdog timer error.
 - (3) All outputs may be turned on if an error occurs in a part, such as an I/O control part, where the CPU module cannot detect any error. To ensure safety operation in such a case, provide a safety mechanism or a fail-safe circuit external to the programmable controller. For a fail-safe circuit example, refer to "General Safety Requirements" in the MELSEC iQ-R Module Configuration Manual.
 - (4) Outputs may remain on or off due to a failure of a component such as a relay and transistor in an output circuit. Configure an external circuit for monitoring output signals that could cause a serious accident.
 - In an output circuit, when a load current exceeding the rated current or an overcurrent caused by a load short-circuit flows for a long time, it may cause smoke and fire. To prevent this, configure an external safety circuit, such as a fuse.
 - Configure a circuit so that the programmable controller is turned on first and then the external power supply. If the external power supply is turned on first, an accident may occur due to an incorrect output or malfunction.
 - For the operating status of each station after a communication failure, refer to manuals relevant to the network. Incorrect output or malfunction due to a communication failure may result in an accident.
-

[Design Precautions]

WARNING

- When connecting an external device with a CPU module or intelligent function module to modify data of a running programmable controller, configure an interlock circuit in the program to ensure that the entire system will always operate safely. For other forms of control (such as program modification, parameter change, forced output, or operating status change) of a running programmable controller, read the relevant manuals carefully and ensure that the operation is safe before proceeding. Improper operation may damage machines or cause accidents.
 - Especially, when a remote programmable controller is controlled by an external device, immediate action cannot be taken if a problem occurs in the programmable controller due to a communication failure. To prevent this, configure an interlock circuit in the program, and determine corrective actions to be taken between the external device and CPU module in case of a communication failure.
 - Do not write any data to the "system area" and "write-protect area" of the buffer memory in the module. Also, do not use any "use prohibited" signals as an output signal from the CPU module to each module. Doing so may cause malfunction of the programmable controller system. For the "system area", "write-protect area", and the "use prohibited" signals, refer to the user's manual for the module used.
 - If a communication cable is disconnected, the network may be unstable, resulting in a communication failure of multiple stations. Configure an interlock circuit in the program to ensure that the entire system will always operate safely even if communications fail. Failure to do so may result in an accident due to an incorrect output or malfunction.
 - To maintain the safety of the programmable controller system against unauthorized access from external devices via the network, take appropriate measures. To maintain the safety against unauthorized access via the Internet, take measures such as installing a firewall.
 - Configure safety circuits external to the programmable controller to ensure that the entire system operates safely even when a fault occurs in the external power supply or the programmable controller. Failure to do so may result in an accident due to an incorrect output or malfunction.
 - (1) Machine home position return is controlled by two kinds of data: a home position return direction and a home position return speed. Deceleration starts when the proximity dog signal turns on. If an incorrect home position return direction is set, motion control may continue without deceleration. To prevent machine damage caused by this, configure an interlock circuit external to the programmable controller.
 - (2) When the module detects an error, the motion slows down and stops or the motion rapidly stops, depending on the stop group setting in parameter. Set the parameter to meet the specifications of a positioning control system. In addition, set the home position return parameter and positioning data within the specified setting range.
 - (3) Outputs may remain on or off, or become undefined due to a failure of a component such as an insulation element and transistor in an output circuit, where the module cannot detect any error. In a system that the incorrect output could cause a serious accident, configure an external circuit for monitoring output signals.
 - If safety standards (ex., robot safety rules, etc.) apply to the system using the module, servo amplifier and servomotor, make sure that the safety standards are satisfied.
 - Construct a safety circuit externally of the module or servo amplifier if the abnormal operation of the module or servo amplifier differs from the safety directive operation in the system.
-

[Design Precautions]

WARNING

- Do not remove the SSCNETIII cable while turning on the control circuit power supply of the module and servo amplifier. Do not see directly the light generated from SSCNETIII connector of the module or servo amplifier and the end of SSCNETIII cable. When the light gets into eyes, you may feel something wrong with eyes. (The light source of SSCNETIII complies with class1 defined in JISC6802 or IEC60825-1.)
-

[Design Precautions]

CAUTION

- Do not install the control lines or communication cables together with the main circuit lines or power cables. Keep a distance of 100 mm or more between them. Failure to do so may result in malfunction due to noise.
 - During control of an inductive load such as a lamp, heater, or solenoid valve, a large current (approximately ten times greater than normal) may flow when the output is turned from off to on. Therefore, use a module that has a sufficient current rating.
 - After the CPU module is powered on or is reset, the time taken to enter the RUN status varies depending on the system configuration, parameter settings, and/or program size. Design circuits so that the entire system will always operate safely, regardless of the time.
 - Do not power off the programmable controller or reset the CPU module while the settings are being written. Doing so will make the data in the flash ROM and SD memory card undefined. The values need to be set in the buffer memory and written to the flash ROM and SD memory card again. Doing so also may cause malfunction or failure of the module.
 - When changing the operating status of the CPU module from external devices (such as the remote RUN/STOP functions), select "Do Not Open in Program" for "Opening Method Setting" in the module parameters. If "Open in Program" is selected, an execution of the remote STOP function causes the communication line to close. Consequently, the CPU module cannot reopen the line, and external devices cannot execute the remote RUN function.
-

[Installation Precautions]

WARNING

- Shut off the external power supply (all phases) used in the system before mounting or removing the module. Failure to do so may result in electric shock or cause the module to fail or malfunction.
-

[Installation Precautions]

CAUTION

- Use the programmable controller in an environment that meets the general specifications in the Safety Guidelines included with the base unit. Failure to do so may result in electric shock, fire, malfunction, or damage to or deterioration of the product.
 - To mount a module, place the concave part(s) located at the bottom onto the guide(s) of the base unit, and push in the module until the hook(s) located at the top snaps into place. Incorrect interconnection may cause malfunction, failure, or drop of the module.
 - To mount a module with no module fixing hook, place the concave part(s) located at the bottom onto the guide(s) of the base unit, push in the module, and fix it with screw(s). Incorrect interconnection may cause malfunction, failure, or drop of the module.
 - When using the programmable controller in an environment of frequent vibrations, fix the module with a screw.
 - Tighten the screws within the specified torque range. Undertightening can cause drop of the screw, short circuit, or malfunction. Overtightening can damage the screw and/or module, resulting in drop, short circuit, or malfunction.
 - When using an extension cable, connect it to the extension cable connector of the base unit securely. Check the connection for looseness. Poor contact may cause malfunction.
 - When using an SD memory card, fully insert it into the SD memory card slot. Check that it is inserted completely. Poor contact may cause malfunction.
 - Securely insert an extended SRAM cassette into the cassette connector of the CPU module. After insertion, close the cassette cover and check that the cassette is inserted completely. Poor contact may cause malfunction.
 - Do not directly touch any conductive parts and electronic components of the module, SD memory card, extended SRAM cassette, or connector. Doing so can cause malfunction or failure of the module.
-

[Wiring Precautions]

WARNING

- Shut off the external power supply (all phases) used in the system before installation and wiring. Failure to do so may result in electric shock or cause the module to fail or malfunction.
 - After installation and wiring, attach a blank cover module (RG60) to each empty slot and an included extension connector protective cover to the unused extension cable connector before powering on the system for operation. Failure to do so may result in electric shock.
-

[Wiring Precautions]

CAUTION

- Individually ground the FG and LG terminals of the programmable controller with a ground resistance of 100 ohms or less. Failure to do so may result in electric shock or malfunction.
 - Use a solderless terminal with an insulation sleeve for terminal block wiring. Note that up to two solderless terminals can be connected per terminal block.
 - Use applicable solderless terminals and tighten them within the specified torque range. If any spade solderless terminal is used, it may be disconnected when the terminal screw comes loose, resulting in failure.
 - Check the rated voltage and signal layout before wiring to the module, and connect the cables correctly. Connecting a power supply with a different voltage rating or incorrect wiring may cause fire or failure.
 - Connectors for external devices must be crimped or pressed with the tool specified by the manufacturer, or must be correctly soldered. Incomplete connections may cause short circuit, fire, or malfunction.
 - Securely connect the connector to the module. Poor contact may cause malfunction.
 - Do not install the control lines or communication cables together with the main circuit lines or power cables. Keep a distance of 100 mm or more between them. Failure to do so may result in malfunction due to noise.
 - When an overcurrent caused by an error of an external device or a failure of a module flows for a long time, it may cause smoke and fire. To prevent this, configure an external safety circuit, such as a fuse.
 - Place the cables in a duct or clamp them. If not, dangling cable may swing or inadvertently be pulled, resulting in damage to the module or cables or malfunction due to poor contact. Do not clamp the extension cables with the jacket stripped. Doing so may change the characteristics of the cables, resulting in malfunction.
 - When disconnecting the communication cable or power cable from the module, do not pull the cable by the cable part. For the cable connected to the terminal block, loosen the terminal screws. Pulling the cable connected to the module may result in malfunction or damage to the module or cable.
 - Check the interface type and correctly connect the cable. Incorrect wiring (connecting the cable to an incorrect interface) may cause failure of the module and external device.
 - Tighten the terminal screws or connector screws within the specified torque range. Undertightening can cause drop of the screw, short circuit, fire, or malfunction. Overtightening can damage the screw and/or module, resulting in drop, short circuit, fire, or malfunction.
 - Tighten the terminal block mounting screws, terminal screws, and module fixing screws within each specified torque range. Undertightening of the terminal block mounting screws and terminal screws can cause short circuit, fire, or malfunction. Overtightening of them can damage the screw and/or module, resulting in drop, short circuit, or malfunction. Undertightening of the module fixing screws can cause drop of the screw. Overtightening of them can damage the screw and/or module, resulting in drop.
 - When disconnecting the cable from the module, do not pull the cable by the cable part. For the cable with connector, hold the connector part of the cable. For the cable connected to the terminal block, loosen the terminal screw. Pulling the cable connected to the module may result in malfunction or damage to the module or cable.
-

[Wiring Precautions]

CAUTION

- Prevent foreign matter such as dust or wire chips from entering the module. Such foreign matter can cause a fire, failure, or malfunction.
 - A protective film is attached to the top of the module to prevent foreign matter, such as wire chips, from entering the module during wiring. Do not remove the film during wiring. Remove it for heat dissipation before system operation.
 - Programmable controllers must be installed in control panels. Connect the main power supply to the power supply module in the control panel through a relay terminal block. Wiring and replacement of a power supply module must be performed by qualified maintenance personnel with knowledge of protection against electric shock. For wiring, refer to the MELSEC iQ-R Module Configuration Manual.
 - For Ethernet cables to be used in the system, select the ones that meet the specifications in the user's manual for the module used. If not, normal data transmission is not guaranteed.
-

[Startup and Maintenance Precautions]

WARNING

- Do not touch any terminal while power is on. Doing so will cause electric shock or malfunction.
 - Correctly connect the battery connector. Do not charge, disassemble, heat, short-circuit, solder, or throw the battery into the fire. Also, do not expose it to liquid or strong shock. Doing so will cause the battery to produce heat, explode, ignite, or leak, resulting in injury and fire.
 - Shut off the external power supply (all phases) used in the system before cleaning the module or retightening the terminal screws, connector screws, or module fixing screws. Failure to do so may result in electric shock.
-

[Startup and Maintenance Precautions]

CAUTION

- When connecting an external device with a CPU module or intelligent function module to modify data of a running programmable controller, configure an interlock circuit in the program to ensure that the entire system will always operate safely. For other forms of control (such as program modification, parameter change, forced output, or operating status change) of a running programmable controller, read the relevant manuals carefully and ensure that the operation is safe before proceeding. Improper operation may damage machines or cause accidents.
 - Especially, when a remote programmable controller is controlled by an external device, immediate action cannot be taken if a problem occurs in the programmable controller due to a communication failure. To prevent this, configure an interlock circuit in the program, and determine corrective actions to be taken between the external device and CPU module in case of a communication failure.
 - Do not disassemble or modify the modules. Doing so may cause failure, malfunction, injury, or a fire.
 - Use any radio communication device such as a cellular phone or PHS (Personal Handy-phone System) more than 25 cm away in all directions from the programmable controller. Failure to do so may cause malfunction.
 - Shut off the external power supply (all phases) used in the system before mounting or removing the module. Failure to do so may cause the module to fail or malfunction.
 - Tighten the screws within the specified torque range. Undertightening can cause drop of the component or wire, short circuit, or malfunction. Overtightening can damage the screw and/or module, resulting in drop, short circuit, or malfunction.
 - After the first use of the product, do not mount/remove the module to/from the base unit, and the terminal block to/from the module, and do not insert/remove the extended SRAM cassette to/from the CPU module more than 50 times (IEC 61131-2 compliant) respectively. Exceeding the limit may cause malfunction.
 - After the first use of the product, do not insert/remove the SD memory card to/from the CPU module more than 500 times. Exceeding the limit may cause malfunction.
 - Do not touch the metal terminals on the back side of the SD memory card. Doing so may cause malfunction or failure of the module.
 - Do not touch the integrated circuits on the circuit board of an extended SRAM cassette. Doing so may cause malfunction or failure of the module.
 - Do not drop or apply shock to the battery to be installed in the module. Doing so may damage the battery, causing the battery fluid to leak inside the battery. If the battery is dropped or any shock is applied to it, dispose of it without using.
 - Startup and maintenance of a control panel must be performed by qualified maintenance personnel with knowledge of protection against electric shock. Lock the control panel so that only qualified maintenance personnel can operate it.
 - Before handling the module, touch a conducting object such as a grounded metal to discharge the static electricity from the human body. Failure to do so may cause the module to fail or malfunction.
 - Before testing the operation, set a low speed value for the speed limit parameter so that the operation can be stopped immediately upon occurrence of a hazardous condition.
 - Confirm and adjust the program and each parameter before operation. Unpredictable movements may occur depending on the machine.
 - When using the absolute position system function, on starting up, and when the module or absolute position motor has been replaced, always perform a home position return.
-

[Startup and Maintenance Precautions]

CAUTION

- Before starting the operation, confirm the brake function.
 - Do not perform a megger test (insulation resistance measurement) during inspection.
 - After maintenance and inspections are completed, confirm that the position detection of the absolute position detection function is correct.
 - Lock the control panel and prevent access to those who are not certified to handle or install electric equipment.
-

[Operating Precautions]

CAUTION

- When changing data and operating status, and modifying program of the running programmable controller from an external device such as a personal computer connected to an intelligent function module, read relevant manuals carefully and ensure the safety before operation. Incorrect change or modification may cause system malfunction, damage to the machines, or accidents.
 - Do not power off the programmable controller or reset the CPU module while the setting values in the buffer memory are being written to the flash ROM in the module. Doing so will make the data in the flash ROM and SD memory card undefined. The values need to be set in the buffer memory and written to the flash ROM and SD memory card again. Doing so also may cause malfunction or failure of the module.
 - Note that when the reference axis speed is specified for interpolation operation, the speed of the partner axis (2nd, 3rd, or 4th axis) may exceed the speed limit value.
 - Do not go near the machine during test operations or during operations such as teaching. Doing so may lead to injuries.
-

[Disposal Precautions]

CAUTION

- When disposing of this product, treat it as industrial waste.
 - When disposing of batteries, separate them from other wastes according to the local regulations. For details on battery regulations in EU member states, refer to the MELSEC iQ-R Module Configuration Manual.
-

[Transportation Precautions]

CAUTION

- When transporting lithium batteries, follow the transportation regulations. For details on the regulated models, refer to the MELSEC iQ-R Module Configuration Manual.
 - The halogens (such as fluorine, chlorine, bromine, and iodine), which are contained in a fumigant used for disinfection and pest control of wood packaging materials, may cause failure of the product. Prevent the entry of fumigant residues into the product or consider other methods (such as heat treatment) instead of fumigation. The disinfection and pest control measures must be applied to unprocessed raw wood.
-

CONDITIONS OF USE FOR THE PRODUCT

(1) Mitsubishi programmable controller ("the PRODUCT") shall be used in conditions;

- i) where any problem, fault or failure occurring in the PRODUCT, if any, shall not lead to any major or serious accident; and
- ii) where the backup and fail-safe function are systematically or automatically provided outside of the PRODUCT for the case of any problem, fault or failure occurring in the PRODUCT.

(2) The PRODUCT has been designed and manufactured for the purpose of being used in general industries.

MITSUBISHI SHALL HAVE NO RESPONSIBILITY OR LIABILITY (INCLUDING, BUT NOT LIMITED TO ANY AND ALL RESPONSIBILITY OR LIABILITY BASED ON CONTRACT, WARRANTY, TORT, PRODUCT LIABILITY) FOR ANY INJURY OR DEATH TO PERSONS OR LOSS OR DAMAGE TO PROPERTY CAUSED BY the PRODUCT THAT ARE OPERATED OR USED IN APPLICATION NOT INTENDED OR EXCLUDED BY INSTRUCTIONS, PRECAUTIONS, OR WARNING CONTAINED IN MITSUBISHI'S USER, INSTRUCTION AND/OR SAFETY MANUALS, TECHNICAL BULLETINS AND GUIDELINES FOR the PRODUCT.

("Prohibited Application")

Prohibited Applications include, but not limited to, the use of the PRODUCT in;

- Nuclear Power Plants and any other power plants operated by Power companies, and/or any other cases in which the public could be affected if any problem or fault occurs in the PRODUCT.
- Railway companies or Public service purposes, and/or any other cases in which establishment of a special quality assurance system is required by the Purchaser or End User.
- Aircraft or Aerospace, Medical applications, Train equipment, transport equipment such as Elevator and Escalator, Incineration and Fuel devices, Vehicles, Manned transportation, Equipment for Recreation and Amusement, and Safety devices, handling of Nuclear or Hazardous Materials or Chemicals, Mining and Drilling, and/or other applications where there is a significant risk of injury to the public or property.

Notwithstanding the above, restrictions Mitsubishi may in its sole discretion, authorize use of the PRODUCT in one or more of the Prohibited Applications, provided that the usage of the PRODUCT is limited only for the specific applications agreed to by Mitsubishi and provided further that no special quality assurance or fail-safe, redundant or other safety features which exceed the general specifications of the PRODUCTS are required. For details, please contact the Mitsubishi representative in your region.

INTRODUCTION

Thank you for purchasing the Mitsubishi Electric MELSEC iQ-R series programmable controllers.

This manual describes the functions and programming of the relevant products listed below. Before using this product, please read this manual and the relevant manuals carefully and develop familiarity with the functions and performance of the MELSEC iQ-R series programmable controller to handle the product correctly.

When applying the program examples provided in this manual to an actual system, ensure the applicability and confirm that it will not cause system control problems.

Please make sure that the end users read this manual.

Relevant products

RD77MS2, RD77MS4, RD77MS8, RD77MS16
RD77GF4, RD77GF8, RD77GF16, RD77GF32

Point

Symbols used in this manual are shown below.

A serial No. is inserted in the "****" mark.

- [Pr.**]: Symbols indicating positioning parameter or home position return parameter items
- [Da.**]: Symbols indicating positioning data or block start data items
- [Md.**]: Symbols indicating monitor data items
- [Cd.**]: Symbols indicating control data items
- [RD77MS]: Symbols indicating that it corresponds to only RD77MS
- [RD77GF]: Symbols indicating that it corresponds to only RD77GF

COMPLIANCE WITH EMC AND LOW VOLTAGE DIRECTIVES

Method of ensuring compliance

To ensure that Mitsubishi programmable controllers maintain EMC and Low Voltage Directives when incorporated into other machinery or equipment, certain measures may be necessary. Please refer to one of the following manuals.

 MELSEC iQ-R Module Configuration Manual

 Safety Guidelines (This manual is included with the base unit.)

The CE mark on the side of the programmable controller indicates compliance with EMC and Low Voltage Directives.

Additional measures

To ensure that this product maintains EMC and Low Voltage Directives, please refer to one of the following manuals.

 MELSEC iQ-R Module Configuration Manual

 Safety Guidelines (This manual is included with the base unit.)

CONTENTS

SAFETY PRECAUTIONS	1
CONDITIONS OF USE FOR THE PRODUCT	9
INTRODUCTION	10
COMPLIANCE WITH EMC AND LOW VOLTAGE DIRECTIVES	10
RELEVANT MANUALS	13
TERMS	14
CHAPTER 1 OUTLINE OF ADVANCED SYNCHRONOUS CONTROL	15
1.1 Outline of Synchronous Control	15
1.2 Performance Specifications	19
1.3 Operation Method of Synchronous Control	22
Synchronous control execution procedure	22
Starting/ending for synchronous control	23
Stop operation of output axis	26
CHAPTER 2 INPUT AXIS MODULE	28
2.1 Servo Input Axis	28
Overview of servo input axis	28
Servo input axis parameters	30
Servo input axis monitor data	33
2.2 Synchronous Encoder Axis	35
Overview of synchronous encoder axis	35
Setting method for synchronous encoder	38
Synchronous encoder axis parameters	46
Synchronous encoder axis parameters via link device [RD77GF]	52
Synchronous encoder axis control data	55
Synchronous encoder axis monitor data	59
CHAPTER 3 CAM FUNCTION	62
3.1 Control Details for Cam Function	62
3.2 Create Cam Data	69
Memory configuration of cam data	69
Cam data operation function	74
Cam auto-generation function	79
CHAPTER 4 ADVANCED SYNCHRONOUS CONTROL	91
4.1 Main Shaft Module	91
Overview of main shaft module	91
Main shaft parameters	92
Main shaft clutch parameters	94
Main shaft clutch control data	100
4.2 Auxiliary Shaft Module	101
Overview of auxiliary shaft module	101
Auxiliary shaft parameters	101
Auxiliary shaft clutch parameters	103
Auxiliary shaft clutch control data	109
4.3 Clutch	110
Overview of clutch	110

Control method for clutch	110
Smoothing method for clutch.....	117
Use example of clutch.....	122
4.4 Speed Change Gear Module.....	123
Overview of speed change gear module.....	123
Speed change gear parameters	124
4.5 Output Axis Module.....	125
Overview of output axis module	125
Output axis parameters.....	127
4.6 Synchronous Control Change Function	131
Overview of synchronous control change function	131
Synchronous control change control data.....	131
4.7 Synchronous Control Monitor Data.....	135
4.8 Phase Compensation Function	140
4.9 Output Axis Sub Functions	142
CHAPTER 5 ADVANCED SYNCHRONOUS CONTROL INITIAL POSITION	143
<hr/>	
5.1 Synchronous Control Initial Position	143
5.2 Synchronous Control Initial Position Parameters	147
5.3 Cam Axis Position Restoration Method	150
Cam axis current value per cycle restoration	150
Cam reference position restoration	154
Cam axis feed current value restoration	156
5.4 Synchronous Control Analysis Mode	159
5.5 Cam Position Calculation Function	162
Cam position calculation control data	162
Cam position calculation monitor data.....	164
5.6 Method to Restart Synchronous Control	169
APPENDICES	170
<hr/>	
Appendix 1 List of Buffer Memory Addresses (for Synchronous Control).....	170
Appendix 2 Sample Program of Synchronous Control of the RD77MS	181
INDEX	186
<hr/>	
REVISIONS.....	188
WARRANTY	189
TRADEMARKS	190

RELEVANT MANUALS

Manual name [manual number]	Description	Available form
MELSEC iQ-R Simple Motion Module User's Manual (Advanced Synchronous Control) [IB-0300249ENG] (This manual)	Functions and programming for the synchronous control of the Simple Motion module	Print book e-Manual PDF
MELSEC iQ-R Simple Motion Module User's Manual (Startup) [IB-0300245ENG]	Specifications, procedures before operation, system configuration, wiring, and operation examples of the Simple Motion module	Print book e-Manual PDF
MELSEC iQ-R Simple Motion Module User's Manual (Application) [IB-0300247ENG]	Functions, input/output signals, buffer memory, parameter settings, programming, and troubleshooting of the Simple Motion module	Print book e-Manual PDF
MELSEC iQ-R Simple Motion Module User's Manual (Network) [IB-0300307ENG]	Functions, parameter settings, troubleshooting and buffer memory of CC-Link IE Field Network	Print book e-Manual PDF

This manual does not include information on the module function blocks.

For details, refer to the Function Block Reference for the module used.

Point

e-Manual refers to the Mitsubishi Electric FA electronic book manuals that can be browsed using a dedicated tool.

e-Manual has the following features:

- Required information can be cross-searched in multiple manuals.
- Other manuals can be accessed from the links in the manual.
- The hardware specifications of each part can be found from the product figures.
- Pages that users often browse can be bookmarked.
- Sample programs can be copied to an engineering tool.

TERMS

Unless otherwise specified, this manual uses the following terms.

Term	Description
16-axis module	A generic term for RD77MS16
2-axis module	A generic term for RD77MS2
32-axis module	A generic term for RD77GF32
4-axis module	A generic term for RD77MS4
8-axis module	A generic term for RD77MS8
Axis	Another term for a servo amplifier
Buffer memory	A memory in an intelligent function module, where data (such as setting values and monitoring values) are stored. When using the CPU module, the memory is indicated for storing data (such as setting values and monitored values) of the Ethernet function and data used for data communication of the multiple CPU function.
CC-Link IE Field Network	A high-speed and large-capacity open field network that is based on Ethernet (1000BASE-T)
CPU module	The abbreviation for the MELSEC iQ-R series CPU module
Device	A device (X, Y, M, D, or others) in a CPU module
Engineering tool	A generic term for GX Works3 and MR Configurator2
Global label	A label that is enabled for all program data when creating multiple program data in the project. There are two types of global labels: module label that is automatically generated by GX Works3 and label that can be created for the any of the specified devices.
GX Works3	The product name of the software package for the MELSEC programmable controllers
Intelligent function module	A MELSEC iQ-R series module that has functions other than input and output, such as an A/D converter module and D/A converter module
Label	A label that represents a device in a given character string
Link device	A device (RX, RY, RWr, or RWw) in a module on CC-Link IE Field Network
Link scan (Link scan time)	Time required for all the stations on the network to transmit data. The link scan time depends on data volume and the number of transient transmission requests.
Module label	A label that represents one of memory areas (I/O signals and buffer memory areas) specific to each module in a given character string. GX Works3 automatically generates this label, which can be used as a global label.
MR Configurator2	The product name of the setup software for the servo amplifier
MR-J3(W)-B	MR-J3-_B_(-RJ)/MR-J3W-_B_ Servo amplifier series
MR-J4(W)-B	MR-J4-_B_(-RJ)/MR-J4W-_B_ Servo amplifier series
MR-J4-B-RJ	MR-J4-_B_-RJ Servo amplifier series
MR-J4-GF	MR-J4-_GF_(-RJ) Servo amplifier series
MR-J4-GF-RJ	MR-J4-_GF_-RJ Servo amplifier series
MR-JE-B(F)	MR-JE-_B_/MR-JE-_BF_ Servo amplifier series
RD77GF	Another term for the MELSEC iQ-R series Simple Motion module (compatible with CC-Link IE Field Network)
RD77MS	Another term for the MELSEC iQ-R series Simple Motion module (compatible with SSCNETⅢ/H)
Remote input (RX)	Bit data input from a slave station to the master station (For some areas in a local station, data are input in the opposite direction.)
Remote output (RY)	Bit data output from the master station to a slave station (For some areas in a local station, data are output in the opposite direction.)
Remote register (RWr)	Word data input from a slave station to the master station (For some areas in a local station, data are input in the opposite direction.)
Remote register (RWw)	Word data output from the master station to a slave station (For some areas in a local station, data are output in the opposite direction.)
Servo amplifier	A generic term for a drive unit Unless specified in particular, indicates the motor driver unit of the sequential command method which is controlled by the Simple Motion module (belonging to own station).
Simple Motion module	The abbreviation for the MELSEC iQ-R series Simple Motion module
SSCNETⅢ*1	High speed synchronous communication network between RD77MS and servo amplifier
SSCNETⅢ/H*1	

*1 SSCNET: Servo System Controller NETwork

The outline, specifications and the operation method of synchronous control using the Simple Motion module are explained in this chapter.

This chapter helps to understand what can be done using the positioning system and which procedure to use for a specific purpose.

1.1 Outline of Synchronous Control

"Synchronous control" can be achieved using software instead of controlling mechanically with gear, shaft, speed change gear or cam, etc.

"Synchronous control" synchronizes movement with the input axis (servo input axis or synchronous encoder axis), by setting "the advanced synchronous control parameters" and starting synchronous control on each output axis.

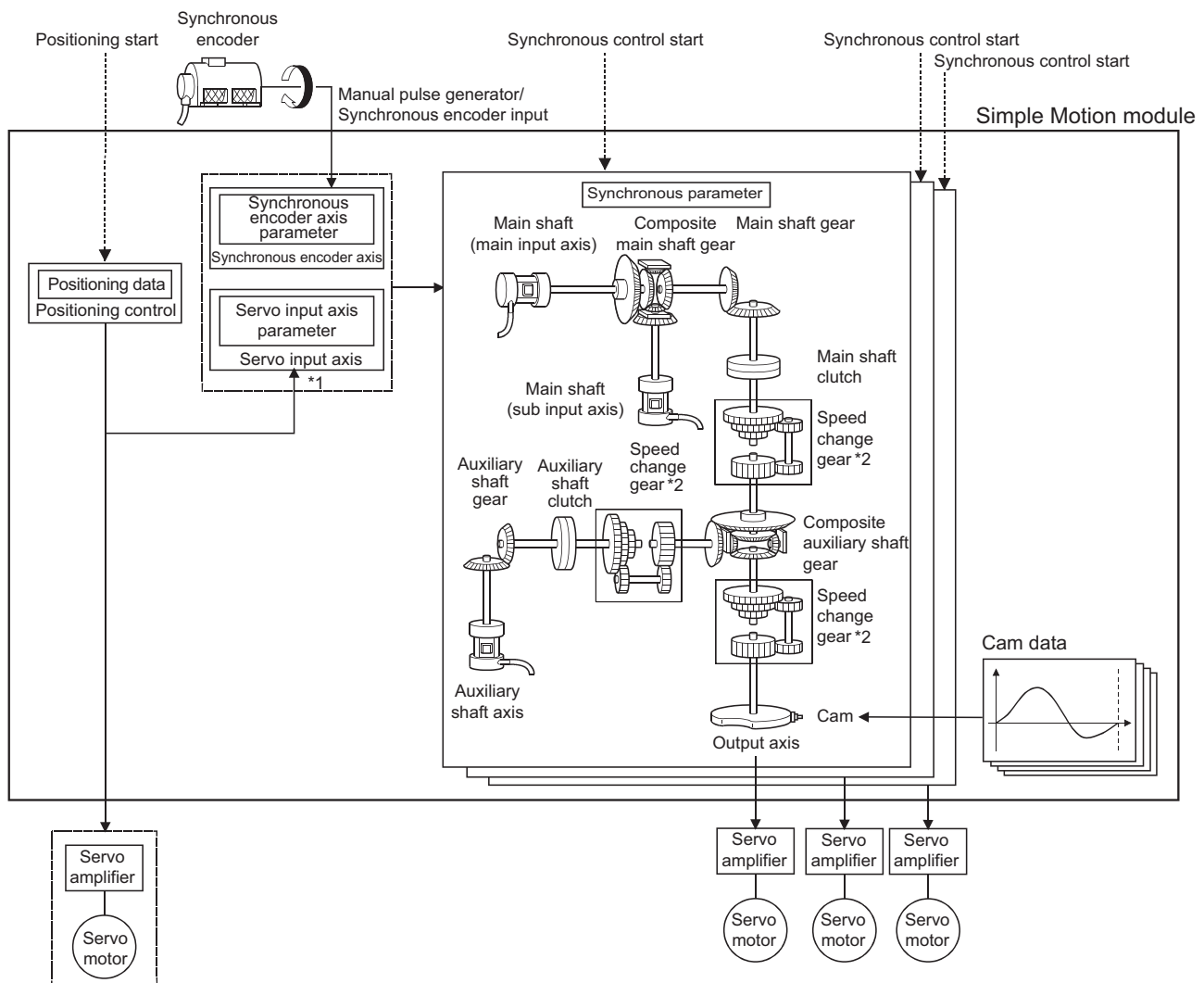

It is possible to control without amplifier by setting the virtual servo amplifier.

*1 It is possible to drive the servo input axis except for the positioning control (home position return, manual control, speed-torque control, synchronous control).

For details on the positioning control, the home position return, the manual control and the speed-torque control, refer to the following.

📖 MELSEC iQ-R Simple Motion Module User's Manual (Application)

*2 Speed change gear can be arranged on one of "Main shaft side", "Auxiliary shaft side" or "After composite auxiliary shaft gear".

List of synchronous control module

The module is used in synchronous control as follows.

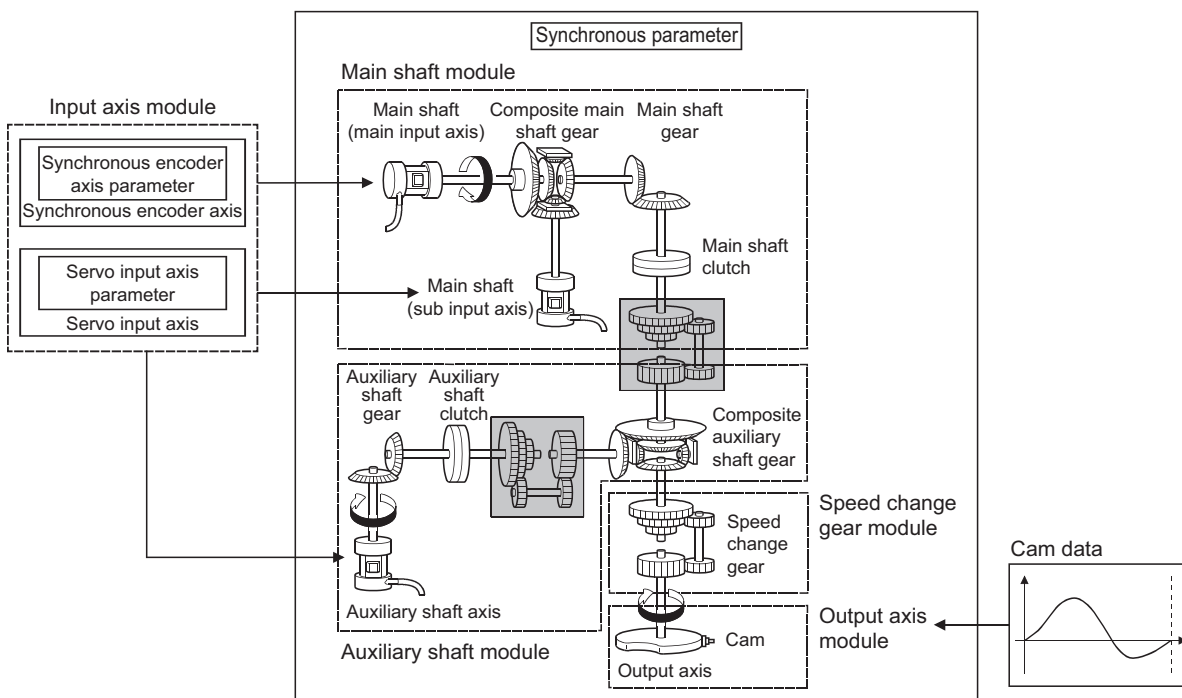

Point

- Input axis module can be set to one of servo input axis or synchronous encoder axis.
- Speed change gear can be arranged on one of main shaft side, auxiliary shaft side or after composite auxiliary shaft gear.
- Set the movement amount of input axis module as large as possible to prevent the speed fluctuation of output axis module in the synchronous control. If the movement amount of input axis module is small, the speed fluctuation of output axis module may occur depending on the setting for advanced synchronous parameter.
- The following items can be monitored in the "Synchronous Control Image" window using the Simple Motion Module Setting Function; each synchronous control monitor data and the rotation direction of main shaft main input axis, main shaft sub input axis, auxiliary shaft axis, and output axis (cam axis feed current value)





Input axis

- Input axis module

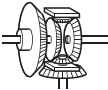

Name	Parts	Function description	Maximum number of usable					Reference	
			per module						per axis
			2-axis module [RD77MS]	4-axis module	8-axis module	16-axis module	32-axis module [RD77GF]		
Servo input axis	—	• Used to drive the input axis with the position of the servomotor controlled by the Simple Motion module.	2	4	8	16	32	—	Page 28 Servo Input Axis
Synchronous encoder axis	—	• Used to drive the input axis with input pulse from the synchronous encoder.	RD77MS	4	—	—	—	—	Page 35 Synchronous Encoder Axis
			RD77GF	—	4	8	16	32	

■ Output axis

• Main shaft module

Name	Parts	Function description	Maximum number of usable					per axis	Reference
			per module						
			2-axis module [RD77MS]	4-axis module	8-axis module	16-axis module	32-axis module [RD77GF]		
Main shaft main input axis		<ul style="list-style-type: none"> The input axis on the main side of the main shaft module. The reference position on the main shaft. 	2	4	8	16	32	1	Page 91 Main Shaft Module
Main shaft sub input axis		<ul style="list-style-type: none"> The input axis on the sub side of the main shaft module. It is used to input the compensation amount for the position of the main shaft main input axis. 	2	4	8	16	32	1	Page 91 Main Shaft Module
Composite main shaft gear		<ul style="list-style-type: none"> The composite movement amount of the main shaft main input axis and the main shaft sub input axis are transmitted to the main shaft gear. 	2	4	8	16	32	1	Page 91 Main Shaft Module
Main shaft gear		<ul style="list-style-type: none"> The converting movement amount after composite main shaft gear is transmitted by the setting gear ratio. 	2	4	8	16	32	1	Page 91 Main Shaft Module
Main shaft clutch		<ul style="list-style-type: none"> The movement amount of the main shaft is transmitted by the clutch ON/OFF. 	2	4	8	16	32	1	Page 91 Main Shaft Module Page 110 Clutch

• Auxiliary shaft module

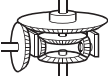
Name	Parts	Function description	Maximum number of usable					per axis	Reference
			per module						
			2-axis module [RD77MS]	4-axis module	8-axis module	16-axis module	32-axis module [RD77GF]		
Auxiliary shaft axis		<ul style="list-style-type: none"> The input axis of the auxiliary shaft module. 	2	4	8	16	32	1	Page 101 Auxiliary Shaft Module
Auxiliary shaft gear		<ul style="list-style-type: none"> The converting movement amount of the auxiliary shaft is transmitted by the setting gear ratio. 	2	4	8	16	32	1	Page 101 Auxiliary Shaft Module
Auxiliary shaft clutch		<ul style="list-style-type: none"> The movement amount of the auxiliary shaft is transmitted by the clutch ON/OFF. 	2	4	8	16	32	1	Page 101 Auxiliary Shaft Module Page 110 Clutch
Composite auxiliary shaft gear		<ul style="list-style-type: none"> The composite movement amount of the main shaft and the auxiliary shaft are transmitted. 	2	4	8	16	32	1	Page 101 Auxiliary Shaft Module

• Speed change gear module

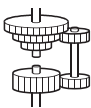
Name	Parts	Function description	Maximum number of usable					Reference	
			per module						per axis
			2-axis module [RD77MS]	4-axis module	8-axis module	16-axis module	32-axis module [RD77GF]		
Speed change gear		<ul style="list-style-type: none"> It is used to change the speed by setting speed change ratio during the operation. 	2	4	8	16	32	1	☞ Page 123 Speed Change Gear Module

• Output axis module

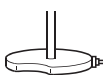
Name	Parts	Function description	Maximum number of usable					Reference	
			per module						per axis
			2-axis module [RD77MS]	4-axis module	8-axis module	16-axis module	32-axis module [RD77GF]		
Output axis		<ul style="list-style-type: none"> The cam conversion is processed based on the input movement amount and the setting cam data. The feed current value is output as the command to the servo amplifier. 	2	4	8	16	32	1	☞ Page 125 Output Axis Module

■ Cam data

Name	Function description	Maximum number of usable	Reference
		per module	
Cam data	<ul style="list-style-type: none"> It controls the operation pattern of the output axis (two-way operation and feed operation), which is corresponding to the input movement amount of the output axis module. 	Up to 256 [RD77MS] Up to 1024 [RD77GF]	☞ Page 62 CAM FUNCTION

1.2 Performance Specifications

Performance specifications

Item		Number of settable axes				
		2-axis module [RD77MS]	4-axis module	8-axis module	16-axis module	32-axis module [RD77GF]
Input axis	Servo input axis	2 axes/module	4 axes/module	8 axes/module	16 axes/module	32 axes/module
	Synchronous encoder axis	RD77MS	4 axes/module			
RD77GF		—	4 axes/module	8 axes/module	16 axes/module	32 axes/module
Composite main shaft gear		1/output axis				
Main shaft main input axis		1 axis/output axis				
Main shaft sub input axis		1 axis/output axis				
Main shaft gear		1/output axis				
Main shaft clutch		1/output axis				
Auxiliary shaft		1 axis/output axis				
Auxiliary shaft gear		1/output axis				
Auxiliary shaft clutch		1/output axis				
Composite auxiliary shaft gear		1/output axis				
Speed change gear		1/output axis				
Output axis (Cam axis)		2 axes/module	4 axes/module	8 axes/module	16 axes/module	32 axes/module

Cam specifications

Item		Specification	
Memory capacity	Cam storage area	256k bytes [RD77MS] 3M bytes [RD77GF]	
	Cam open area	1024k bytes [RD77MS] 16M bytes [RD77GF]	
Number of cam registration*1		Up to 256 [RD77MS] Up to 1024 [RD77GF] (Dependent on memory capacity, cam resolution and coordinate number)	
Comment		Up to 32 characters per cam data	
Cam data	Stroke ratio data format	Cam resolution	256/512/1024/2048/4096/8192/16384/32768
		Stroke ratio	-214.7483648 to 214.7483647 [%]
	Coordinate data format	Coordinate number	2 to 16384 [RD77MS] 2 to 65535 [RD77GF]
		Coordinate data	Input value: 0 to 2147483647 Output value: -2147483648 to 2147483647

*1 The maximum number of cam registration by the cam resolution is shown below. (In case it created by the same cam resolution.)

■ Stroke ratio data format

• RD77MS

Cam resolution	Maximum number of cam registration	
	Cam storage area	Cam open area
256	256	256
512	128	256
1024	64	256
2048	32	128
4096	16	64
8192	8	32
16384	4	16
32768	2	8

• RD77GF

Cam resolution	Maximum number of cam registration	
	Cam storage area	Cam open area
256	1024	
512	1024	
1024	1024	
2048	1024	
4096	1024	
8192	512	
16384	256	
32768	128	

■ Coordinate data format

• RD77MS

Coordinate number	Maximum number of cam registration	
	Cam storage area	Cam open area
128	256	256
256	128	256
512	64	256
1024	32	128
2048	16	64
4096	8	32
8192	4	16
16384	2	8

• RD77GF

Coordinate number	Maximum number of cam registration	
	Cam storage area	Cam open area
128	1024	
256	1024	
512	1024	
1024	1024	
2048	1024	
4096	512	
8192	256	
16384	128	
32768	64	
65535	32	

Cam operation specifications

Item	Specification
Operation method of cam data	(1) Engineering tool Write/read/verify to cam storage area (2) Via buffer memory (Cam data operation function) Write/read to cam storage area and cam open area
Cam auto-generation function	Automatically generate the following cams. <ul style="list-style-type: none"> • Cam for rotary cutter [RD77MS] • Cam for rotary cutter (central reference) [RD77GF] • Easy stroke ratio cam [RD77GF] • Advanced stroke ratio cam [RD77GF]
Cam position calculation function	Calculate the cam position by the program. Used to calculate the cam position for the synchronous control initial position before starting synchronous control.

Synchronous encoder axis specifications

Item	Specification	
Number of control axes	2-axis module: 4, 4-axis module: 4, 8-axis module: 4, 16-axis module: 4 [RD77MS] 4-axis module: 4, 8-axis module: 8, 16-axis module: 16, 32-axis module: 32 [RD77GF]	
Synchronous encoder axis type	Incremental synchronous encoder [RD77MS]/ Synchronous encoder via servo amplifier/ Synchronous encoder via CPU/ Synchronous encoder via link device [RD77GF]	
Control unit	mm, inch, degree, pulse (Possible to select the decimal places of position unit and speed unit)	
Unit conversion	Numerator	-2147483648 to 2147483647 [Synchronous encoder axis position unit]
	Denominator	1 to 2147483647 [pulse]
Length per cycle setting range	1 to 2147483647 [Synchronous encoder axis position unit]	
Current value range	Current value	-2147483648 to 2147483647 [Synchronous encoder axis position unit]
	Current value per cycle	0 to (Length per cycle - 1) [Synchronous encoder axis position unit]
Control method	Control instruction	Current value change, Counter disable, Counter enable
	Current value setting address	Address setting range: -2147483648 to 2147483647 [Synchronous encoder axis position unit]

1.3 Operation Method of Synchronous Control

Synchronous control execution procedure

The synchronous control is executed using the following procedure.

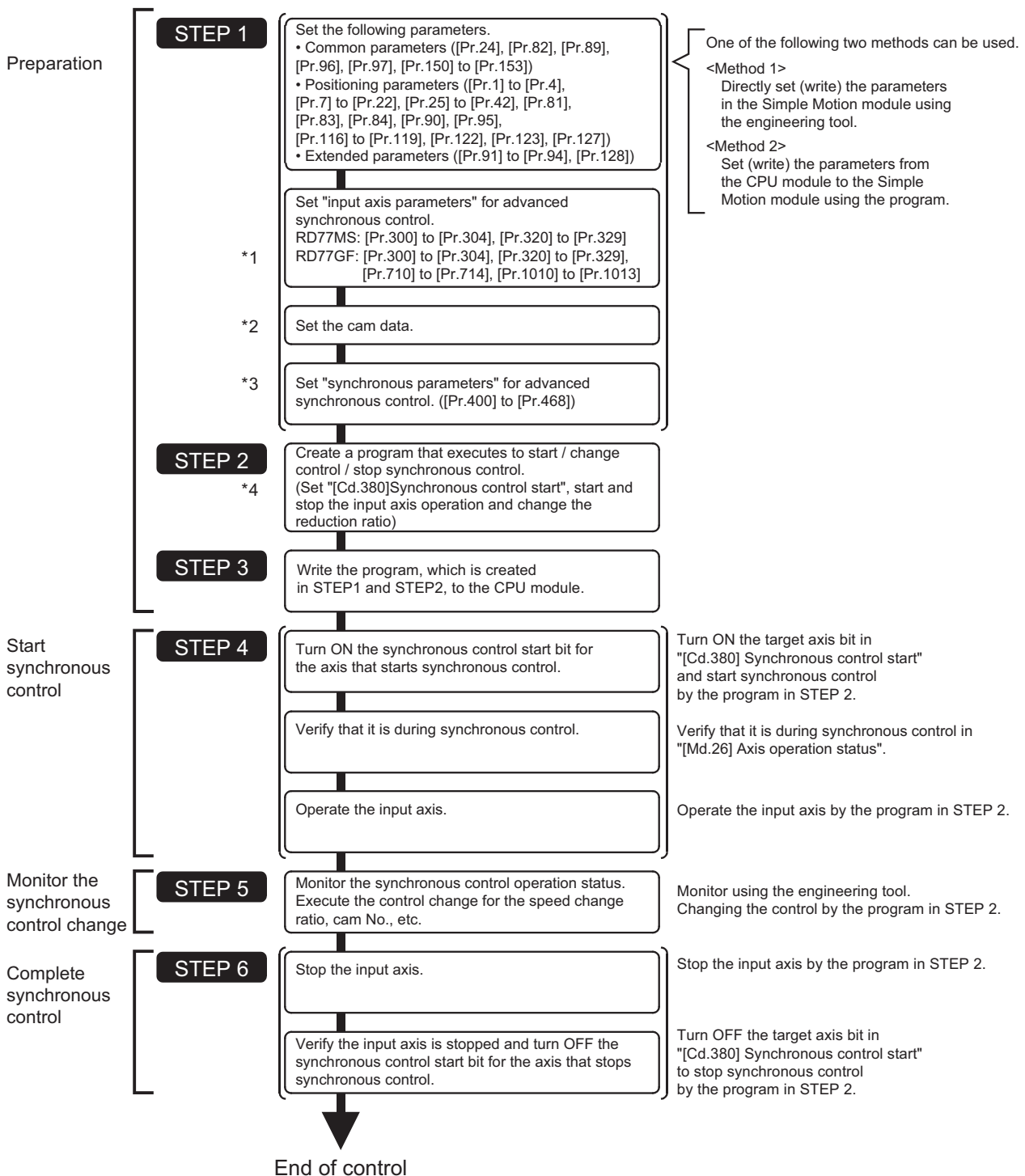

*1 Page 28 INPUT AXIS MODULE

*2 Page 62 CAM FUNCTION

*3 Page 91 ADVANCED SYNCHRONOUS CONTROL, Page 147 Synchronous Control Initial Position Parameters

*4 Page 181 Sample Program of Synchronous Control of the RD77MS

Precautions

- Mechanical elements such as limit switches are considered as already installed.
- Parameter settings for positioning control apply for all axes with the Simple Motion module.
- Be sure to execute the home position return when the home position return request flag is ON.

Starting/ending for synchronous control

Set the advanced synchronous control parameters for each output axis to start synchronous control.

The status changes to synchronous control after the advanced synchronous control parameters are analyzed at the start of synchronous control, and the output axes synchronize with input axis operations.

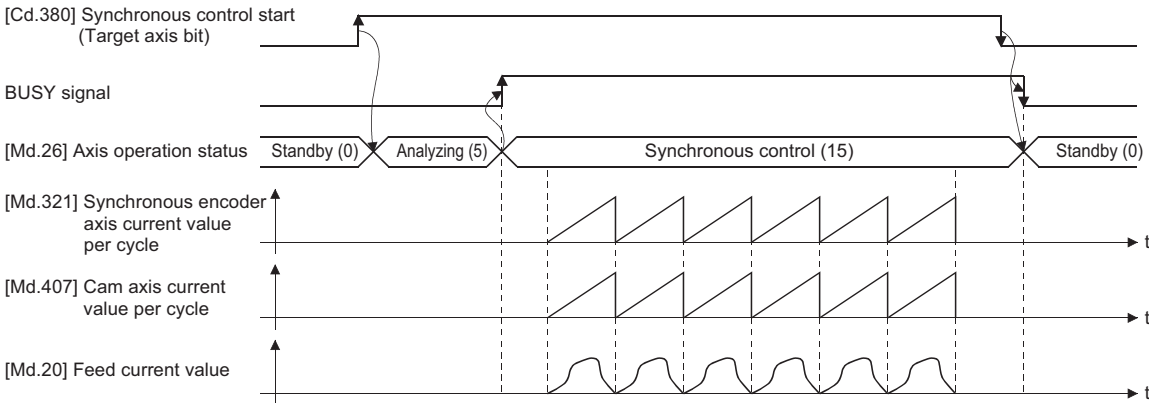

Synchronous control system control data

Setting item	Setting details	Setting value	Default value	Buffer memory address	
				Axis 1 to axis 16	Axis 17 to axis 32
[Cd.380] Synchronous control start	<ul style="list-style-type: none"> • Synchronous control begins if the target axis bit is turned ON. • Synchronous control ends if the bit is turned OFF during synchronous control. Fetch cycle: Operation cycle	■Set the target axis in bit. Set with the following two buffer memory addresses. <ul style="list-style-type: none"> • Buffer memory address: 36320 (bit0: axis 1 to bit15: axes 16^{*1}) • Buffer memory address: 1036320 (bit0: axes 17 to bit15: axes 32^{*1}) Buffer memory address: 36320 b15 b12 b8 b4 b0 Axis 1 to 16 Buffer memory address: 1036320 b15 b12 b8 b4 b0 Axis 17 to 32 OFF : Synchronous control end ON : Synchronous control start	0	36320	1036320

*1 The range from axis 1 to 2 is valid in the 2-axis module, from axis 1 to 4 is valid in the 4-axis module, from axis 1 to 8 is valid in the 8-axis module, from axis 1 to 16 is valid in the 16-axis module, and from axis 1 to 32 is valid in the 32-axis module.

Starting method for synchronous control

Synchronous control can be started by turning the target axis bit from OFF to ON in "[Cd.380] Synchronous control start" after setting the advanced synchronous control parameters.

"5: Analyzing" is set in "[Md.26] Axis operation status" at the synchronous control start, and the advanced synchronous control parameters are analyzed. The BUSY signal turns ON after completion of analysis, and "15: Synchronous control" is set in "[Md.26] Axis operation status".

Start the input axis operation after confirming that "15: Synchronous control" is set in "[Md.26] Axis operation status".

Ending method for synchronous control

Synchronous control can be ended by turning the target axis bit from ON to OFF in "[Cd.380] Synchronous control start" after the input axis operation is stopped.

The BUSY signal turns OFF at the synchronous control end, and "0: Standby" is set in "[Md.26] Axis operation status" at the output axis stop.

Synchronous control can also be ended by turning the target axis bit from ON to OFF in "[Cd.380] Synchronous control start" during the input axis operation. However, it is recommended to end after stopping the input axis operation since the output axis stops immediately.

Refer to the following for the stop operation of output axis at the synchronous control end.

 Page 26 Stop operation of output axis

Starting history

The starting history is updated when starting synchronous control. "9020: Synchronous control operation" is stored in "[Md.4] Start No.".

Status when starting synchronous control

The following bits in "[Md.31] Status" are turned OFF when starting synchronous control in the same way as for the positioning control start.

Bit	Details
b0	In speed control flag
b1	Speed-position switching latch flag
b2	Command in-position flag
b4	Home position return complete flag
b5	Position-speed switching latch flag
b10	Speed change 0 flag

- If bit for multiple axes are turned ON simultaneously in "[Cd.380] Synchronous control start", control is not started simultaneously since the analysis is processed for each axis in numerical order. When the multiple axes must be started simultaneously, start the input axis operation after confirming that all axes are configured for the synchronous control.
- If the input axis operates during the analysis at the synchronous control start, the movement amount of the input axis is reflected immediately after the synchronous control start. The output axis might rapidly accelerate depending on the movement amount of the input axis. Start the input axis operation after confirming that are configured for synchronous control.
- The analysis process for synchronous control start might take time depending on the setting of the advanced synchronous control parameters. (When "0: Cam axis current value per cycle restoration" is set in "[Pr.462] Cam axis position restoration object" and the cam (cam resolution: 32768) is searched: About 26 ms, When "0: Cam axis current value per cycle restoration" is set in "[Pr.462] Cam axis position restoration object" and the cam (cam resolution: 256) is searched: About 0.4 ms [RD77MS], about 0.5 ms [RD77GF]) Set "1: Cam reference position restoration" or "2: Cam axis feed current value restoration" in "[Pr.462] Cam axis position restoration object" to start synchronous control at high speed.
- When the advanced synchronous control parameters are set to the value outside the setting range, the synchronous control does not start, and the input axis error No. is stored in the monitor data.

Stop operation of output axis

If the following causes occur in stopping the output axis during synchronous control, synchronous control is completed after stops processing for the output axis (BUSY signal is OFF, axis operation status is standby).

Synchronous alignment must be executed for the output axis to restart the synchronous control ( Page 125 Output Axis Module).

Stop cause	Stop process
The target axis bit of "[Cd.380] Synchronous control start" is turned from ON to OFF.	Immediate stop
Software stroke limit error occurrence	
Emergency stop	
Forced stop	
Stop group1 to 3*1 (Stop with hardware stroke limit or stop command)	Deceleration stop

*1 Refer to the following for details.

 MELSEC iQ-R Simple Motion Module User's Manual (Application)

Immediate stop

The operation stops without decelerate. The Simple Motion module immediately stops the command, but the operation will coast for the droop pulses accumulated in the deviation counter of the servo amplifier.

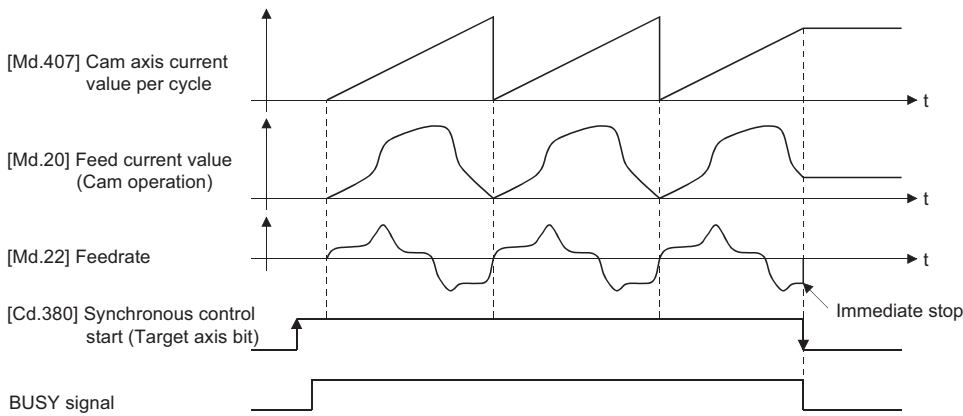

Deceleration stop

The output axis stops with deceleration according to the setting in "[Pr.37] Stop group 1 rapid stop selection" to "[Pr.39] Stop group 3 rapid stop selection". The deceleration time is set in "[Pr.446] Synchronous control deceleration time" for deceleration stop, and in "[Pr.36] Rapid stop deceleration time" for rapid stop. The slope of deceleration is as follows.

$$\text{Slope of deceleration} = \frac{[\text{Pr.8}] \text{ Speed limit value}}{\text{Deceleration time (Rapid stop deceleration time)}}$$

The cam axis current value per cycle is not updated, and only the feed current value is updated, since the deceleration stop begins. Therefore, the path of the feed current value is drawn regardless the cam operation with deceleration stop.

The input axis must be stopped when the output axis is stop synchronizing with the input axis.

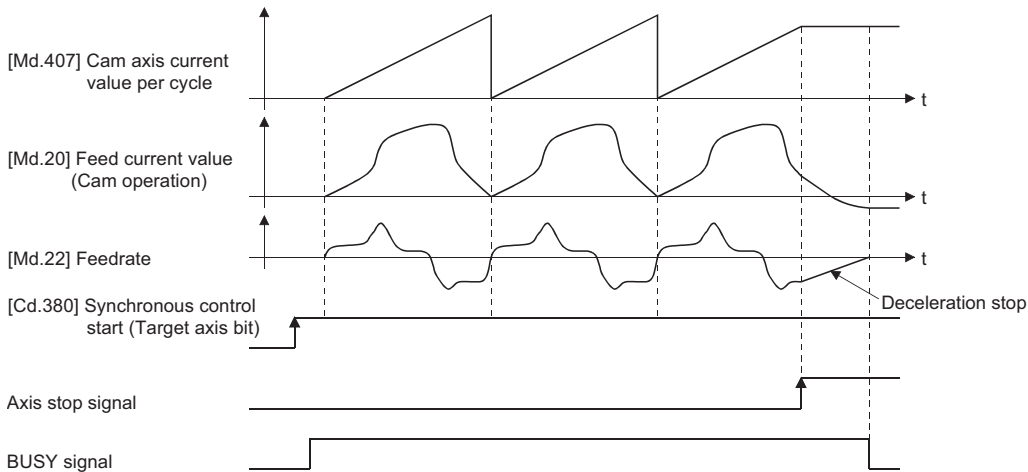

2 INPUT AXIS MODULE

The settings for the parameter and monitor data for the input axis module that used with synchronous control are explained in this chapter.

Refer to the following for details on the connection and control for the servo amplifier and the synchronous encoder that are used for input axis module.

📖 MELSEC iQ-R Simple Motion Module User's Manual (Application)

2.1 Servo Input Axis

Overview of servo input axis

The servo input axis is used to drive the input axis based on the position of the servomotor that is being controlled by the Simple Motion module.

The status of a servo input axis can also be monitored even before the synchronous control start since the setting of a servo input axis is valid after the system's power supply ON.

The following shows the relationship between the position of the servomotor and the servo input axis.

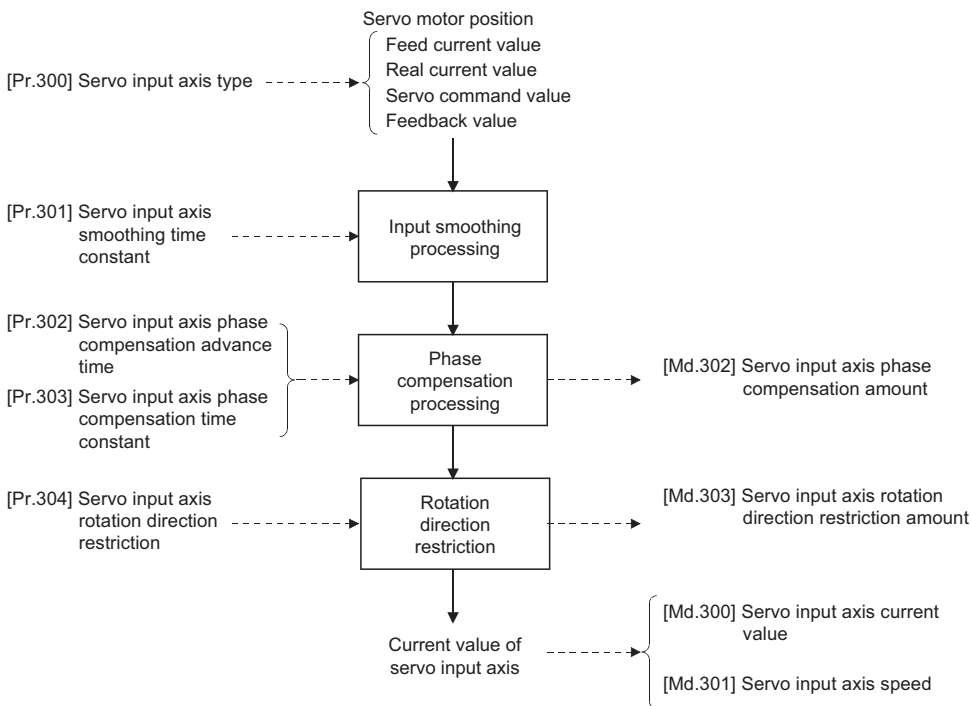

Control method for servo input axis

All controls (including synchronous control) can be executed for a servo input axis.

Refer to the following for the controls other than the synchronous control.

📖 MELSEC iQ-R Simple Motion Module User's Manual (Application)

Point

If the virtual servo amplifier function is set in the servo input axis, synchronous control can be executed by the input value as virtual.

Refer to the following for details on virtual servo amplifier function.

📖 MELSEC iQ-R Simple Motion Module User's Manual (Application)

If "1: Feed current value" or "2: Real current value" is set in "[Pr.300] Servo input axis type", set "1: Update feed current value" in "[Pr.21] Feed current value during speed control" to start the speed position change control. If "0: Do not update feed current value" or "2: Clear feed current value to zero" is set in [Pr.21], the error "Speed-position switching control start in servo input axis not possible" (error code: 1BA7H) will occur and the control will not start.

Units for the servo input axis

The position units and speed units for the servo input axis are shown below for the setting "[Pr.300] Servo input axis type" and "[Pr.1] Unit setting".

■ Servo input axis position units

Setting value of "[Pr.300] Servo input axis type"	Setting value of "[Pr.1] Unit setting"	Servo input axis position unit	Range
1: Feed current value 2: Real current value	0: mm	$\times 10^{-4}$ mm (10^{-1} μ m)	-214748.3648 to 214748.3647 [mm] (-214748364.8 to 214748364.7 [μ m])
	1: inch	$\times 10^{-5}$ inch	-21474.83648 to 21474.83647 [inch]
	2: degree	$\times 10^{-5}$ degree	-21474.83648 to 21474.83647 [degree]
	3: pulse	pulse	-2147483648 to 2147483647 [pulse]
3: Servo command value 4: Feedback value	—	pulse	-2147483648 to 2147483647 [pulse]

■ Servo input axis speed units

Setting value of "[Pr.300] Servo input axis type"	Setting value of "[Pr.1] Unit setting"	Servo input axis speed unit	Range
1: Feed current value 2: Real current value	0: mm	$\times 10^{-2}$ mm/min	-21474836.48 to 21474836.47 [mm/min]
	1: inch	$\times 10^{-3}$ inch/min	-2147483.648 to 2147483.647 [inch/min]
	2: degree	$\times 10^{-3}$ degree/min ^{*1}	-2147483.648 to 2147483.647 [degree/min] ^{*1}
	3: pulse	pulse/s	-2147483648 to 2147483647 [pulse/s]
3: Servo command value 4: Feedback value	—	pulse/s	-2147483648 to 2147483647 [pulse/s]

*1 This will be the speed unit " $\times 10^{-2}$ degree/min" (Range: -21474836.48 to 21474836.47 [degree/min]), when "[Pr.83] Speed control 10 \times multiplier setting for degree axis" is valid.

Point 

- When "1: Feed current value" or "3: Servo command value" is set in "[Pr.300] Servo input axis type", and the servo input axis becomes servo OFF by the servo alarm or forced stop, the amount of value change may be large. This can be prevented by setting "2: Real current value" or "4: Feedback value" in "[Pr.300] Servo input axis type".

Servo input axis parameters

n: Axis No. - 1 (n: Axis No. - 17 for axis 17 to axis 32)

Setting item	Setting details	Setting value	Default value	Buffer memory address	
				Axis 1 to axis 16	Axis 17 to axis 32
[Pr.300] Servo input axis type	<ul style="list-style-type: none"> Set the current value type to be generated of the input value for the servo input axis. Fetch cycle: <u>At power supply ON</u>	■Set in decimal. 0: Invalid 1: Feed current value 2: Real current value 3: Servo command value 4: Feedback value	0	32800+10n	1032800+10n
[Pr.301] Servo input axis smoothing time constant	<ul style="list-style-type: none"> Set to smooth the input value. Fetch cycle: <u>At power supply ON</u>	■Set in decimal. 0 to 5000 [ms]	0	32801+10n	1032801+10n
[Pr.302] Servo input axis phase compensation advance time	<ul style="list-style-type: none"> Set the time to advance or delay the phase. Fetch cycle: <u>Operation cycle</u>	■Set in decimal. -2147483648 to 2147483647 [μ s]	0	32802+10n 32803+10n	1032802+10n 1032803+10n
[Pr.303] Servo input axis phase compensation time constant	<ul style="list-style-type: none"> Set the time constant to affect the phase compensation. Fetch cycle: <u>At power supply ON</u>	■Set in decimal. 0 to 65535 [ms] ^{*1}	10	32804+10n	1032804+10n
[Pr.304] Servo input axis rotation direction restriction	<ul style="list-style-type: none"> Set this parameter to restrict the input movement amount to one direction. Fetch cycle: <u>At power supply ON</u>	■Set in decimal. 0: Without rotation direction restriction 1: Enable only for current value increase direction 2: Enable only for current value decrease direction	0	32805+10n	1032805+10n

*1 Set the value as follows in a program.
 0 to 32767: Set as a decimal.
 32768 to 65535: Convert into a hexadecimal and set.

[Pr.300] Servo input axis type

Set the current value type to be generated of the input value for the servo input axis.

Setting value	Details
0: Invalid	Servo input axis is invalid.
1: Feed current value	Generate the input value based on "[Md.20] Feed current value".
2: Real current value	Generate the input value based on the real current value, which is converted into units of the encoder feedback pulses from the servo amplifier.
3: Servo command value	Generate the input value based on the command pulse for the servo amplifier (a value that the feed current value is converted into encoder pulse units).
4: Feedback value	Generate the input value based on the encoder feedback pulse from the servo amplifier.

Simple Motion module

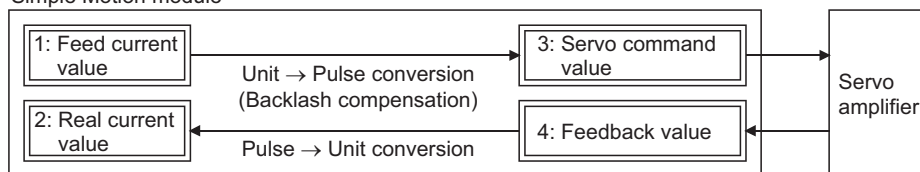

[Pr.301] Servo input axis smoothing time constant

Set the averaging time to execute a smoothing process for the input movement amount from the servo input axis. The smoothing process can moderate speed fluctuation, when the "Real current value" or "Feedback value" is used as input values. The input response is delayed depending on the time corresponding to the setting by smoothing process setting.

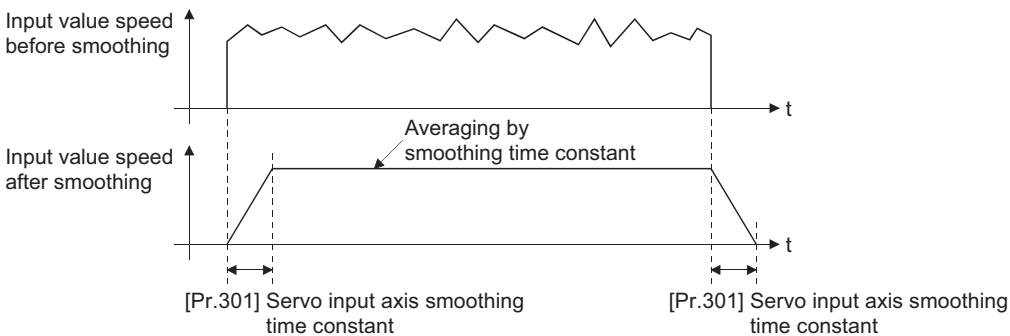

[Pr.302] Servo input axis phase compensation advance time

Set the time to advance or delay the phase (input response) of the servo input axis. Refer to the following for the delay time inherent to the system using the servo input axis.

☞ Page 140 Phase Compensation Function

Setting value	Details
1 to 2147483647 [μ s]	Advance the phase (input response) according to the setting time.
0 [μ s]	Do not execute phase compensation.
-2147483648 to -1 [μ s]	Delay the phase (input response) according to the setting time.

If the setting time is too long, the system experiences overshoot or undershoot at acceleration/deceleration of the input speed. In this case, set longer time to affect the phase compensation amount in "[Pr.303] Servo input axis phase compensation time constant".

[Pr.303] Servo input axis phase compensation time constant

Set the time constant to affect the phase compensation amount for the first order delay. 63 [%] of the phase compensation amount are reflected in the time constant setting.

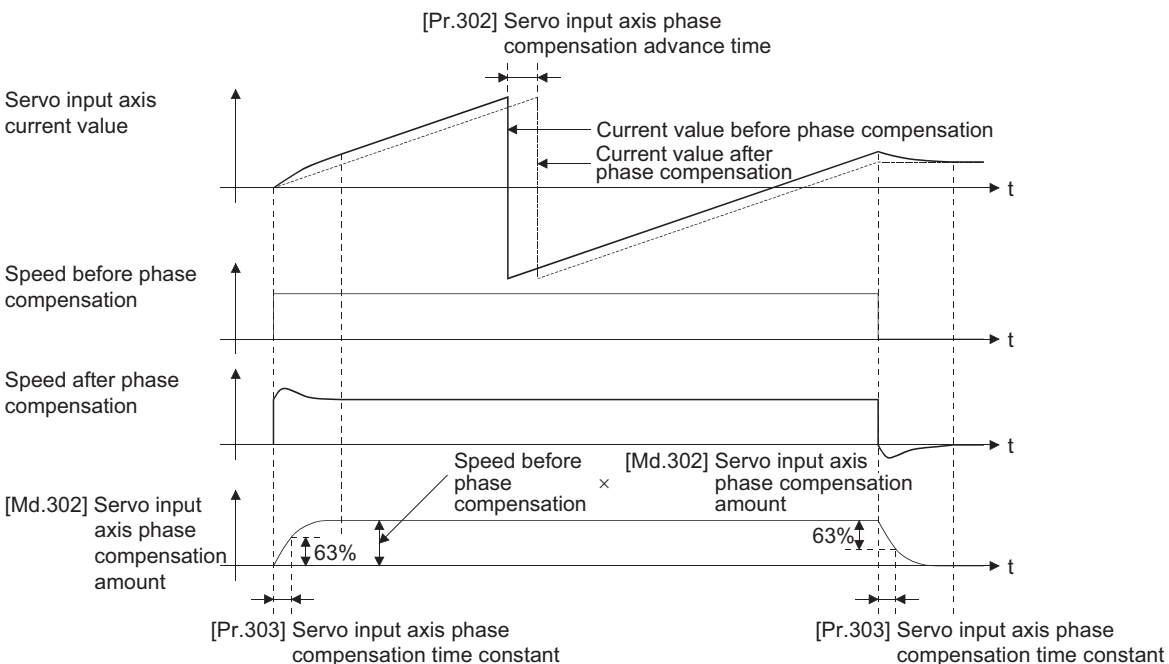

[Pr.304] Servo input axis rotation direction restriction

Set this parameter to restrict the input movement amount for the servo input axis to one direction.

This helps to avoid reverse operation caused by such as machine vibration when "Real current value" or "Feedback value" is used as input values.

Setting value	Details
0: Without rotation direction restriction	Rotation direction restriction is not executed.
1: Enable only for current value increase direction	Enable only the input movement amount in the increasing direction of the servo input axis current value.
2: Enable only for current value decrease direction	Enable only the input movement amount in the decreasing direction of the servo input axis current value.

The input movement amount in the reverse direction of the enabled direction accumulates as a rotation direction restricted amount, and will be reflected when the input movement amount moves in the enabled direction again. Therefore, the current value of servo input does not deviate when the reverse operation is repeated.

The rotation direction restricted amount is set to 0 when the following operations are executed for the servo input axis.

- A servo amplifier is connected
- The home position return is executed
- The current value is changed

For "1: Enable only for current value increase direction" is set in "[Pr.304] Servo input axis rotation direction restriction".

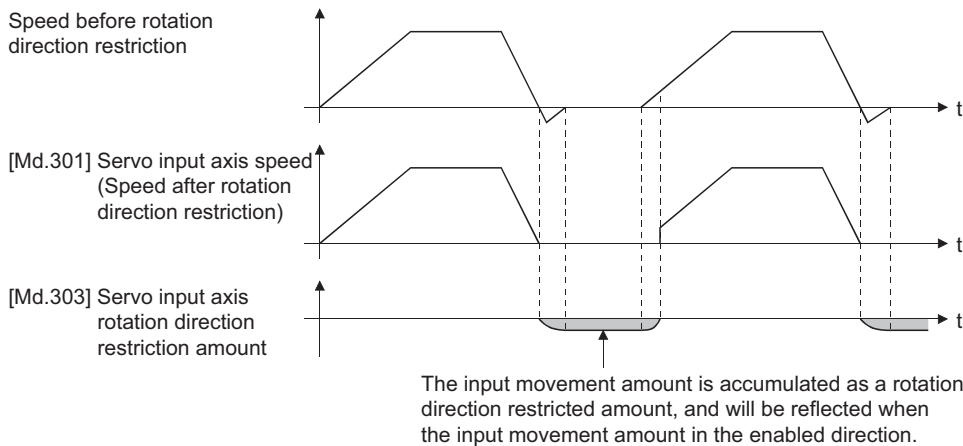

Servo input axis monitor data

n: Axis No. - 1 (n: Axis No. - 17 for axis 17 to axis 32)

Monitor item	Storage details	Monitor value	Buffer memory address	
			Axis 1 to axis 16	Axis 17 to axis 32
[Md.300] Servo input axis current value	<ul style="list-style-type: none"> The current value for the servo input axis is stored. <u>Refresh cycle: Operation cycle</u>	<ul style="list-style-type: none"> Monitoring is carried out in decimal. -2147483648 to 2147483647 [Servo input axis position units^{*1}] 	33120+10n 33121+10n	1033120+10n 1033121+10n
[Md.301] Servo input axis speed	<ul style="list-style-type: none"> The speed for the servo input axis is stored. <u>Refresh cycle: Operation cycle</u>	<ul style="list-style-type: none"> Monitoring is carried out in decimal. -2147483648 to 2147483647 [Servo input axis speed units^{*2}] 	33122+10n 33123+10n	1033122+10n 1033123+10n
[Md.302] Servo input axis phase compensation amount	<ul style="list-style-type: none"> The current phase compensation amount is stored. <u>Refresh cycle: Operation cycle</u>	<ul style="list-style-type: none"> Monitoring is carried out in decimal. -2147483648 to 2147483647 [Servo input axis position units^{*1}] 	33124+10n 33125+10n	1033124+10n 1033125+10n
[Md.303] Servo input axis rotation direction restriction amount	<ul style="list-style-type: none"> While the rotation direction is restricted, the accumulation for the input movement amount in the opposite direction of the enabled direction is stored. <u>Refresh cycle: Operation cycle</u>	<ul style="list-style-type: none"> Monitoring is carried out in decimal. -2147483648 to 2147483647 [Servo input axis position units^{*1}] 	33126+10n 33127+10n	1033126+10n 1033127+10n

*1 Servo input axis position units ( Page 29 Servo input axis position units)

*2 Servo input axis speed units ( Page 29 Servo input axis speed units)

[Md.300] Servo input axis current value

The current value for the servo input axis is stored in servo input axis position units ( Page 29 Servo input axis position units) as follows.

The current value for the servo input axis is the value after processing the smoothing, the phase compensation and the rotation direction restriction.

Setting value of "[Pr.300] Servo input axis type"	Storage details
1: Feed current value 2: Real current value	<ul style="list-style-type: none"> The accumulative current value started with "[Md.20] Feed current value"/"[Md.101] Real current value" for the connection to the servo amplifier is stored. It is also stored in the range from -21474.83648 to 21474.83647 [degree] for degree units. When the "[Md.20] Feed current value"/"[Md.101] Real current value" is changed by the home position return or the current value change, the value is changed to the new current value.
3: Servo command value 4: Feedback value	<ul style="list-style-type: none"> When of the absolute position detection system setting is invalid, the accumulative current value that starts from 0 for the connected servo amplifier is stored. When of the absolute position detection system setting is valid, the accumulative current value that starts from the absolute position command/encoder feedback pulse for the connected servo amplifier is stored. The servo input axis current value will not change, even if the home position return or the current value is changed.

[Md.301] Servo input axis speed

The speed for the servo input axis is stored in servo input axis speed units ( Page 29 Servo input axis speed units). The speed for the servo input axis is the value after processing smoothing, phase compensation, and rotation direction restriction.

[Md.302] Servo input axis phase compensation amount

The phase compensation amount for a servo input axis is stored in servo input axis position units ( Page 29 Servo input axis position units).

The phase compensation amount for a servo input axis is the value after processing smoothing and phase compensation.

[Md.303] Servo input axis rotation direction restriction amount

While the rotation direction is restricted for a servo input axis, the accumulation for input movement amount in the opposite direction of the enabled direction is stored in servo input axis position units ( Page 29 Servo input axis position units) as follows.

Setting value of "[Pr.304] Servo input axis rotation direction restriction"	Storage details
1: Enable only for current value increase direction	A negative accumulation is stored during rotation direction restriction. 0 is stored if there is no restriction.
2: Enable only for current value decrease direction	A positive accumulation is stored during rotation direction restriction. 0 is stored if there is no restriction.

Rotation direction restriction is processed after phase compensation processing. Therefore, if undershoot occurs from phase compensation during deceleration stop, the rotation direction restriction amount might remain.

2.2 Synchronous Encoder Axis

Overview of synchronous encoder axis

The synchronous encoder is used to drive the input axis based on input pulse from a synchronous encoder that is connected externally.

The status of a synchronous encoder axis can also be monitored after the system's power supply turns ON.

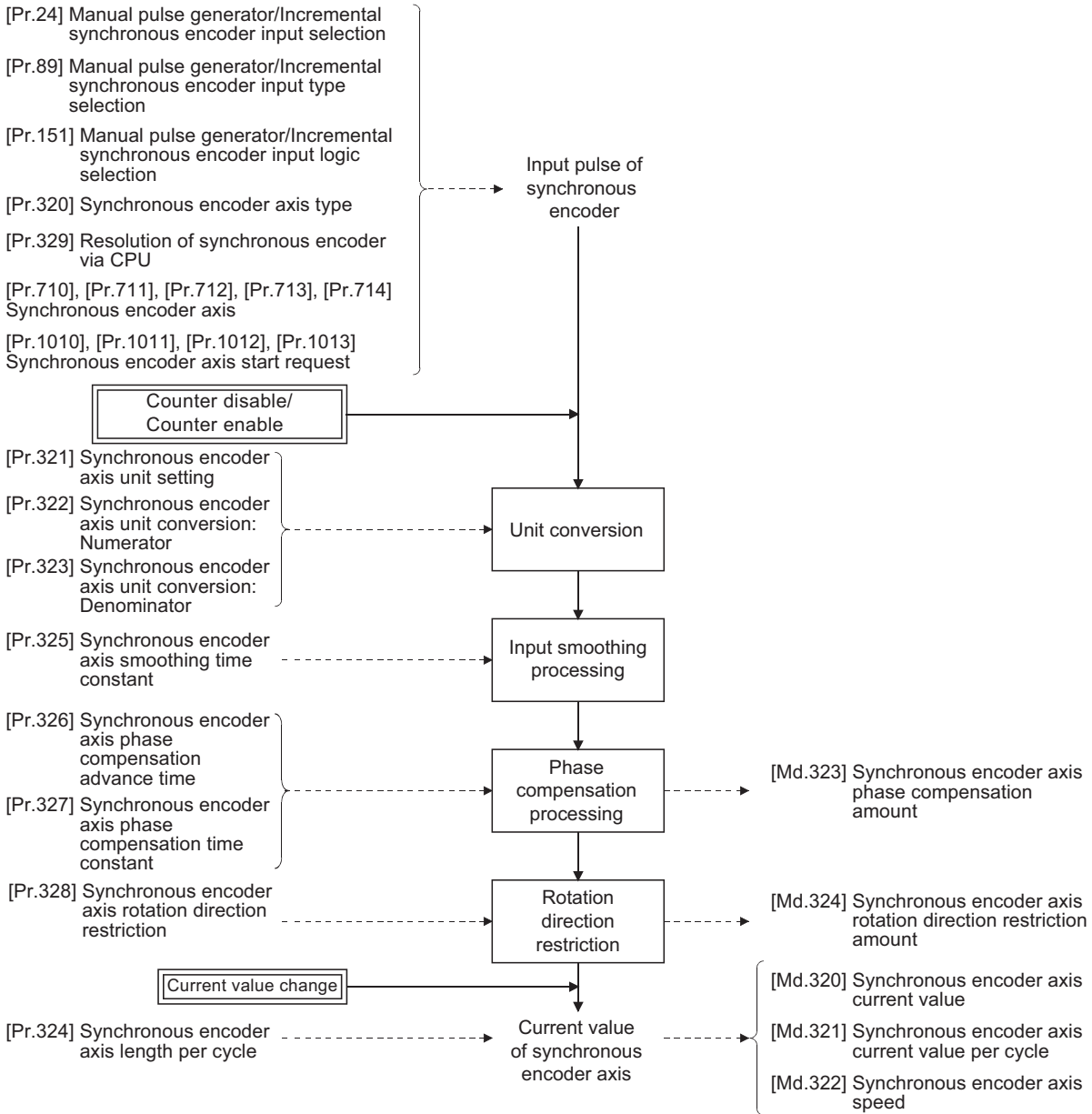

Synchronous encoder axis type

The following 4 types of synchronous encoders can be used for the synchronous encoder axis.

Refer to the following for the setting method for each synchronous encoder axis.

☞ Page 38 Setting method for synchronous encoder

Synchronous encoder axis type	Details
Incremental synchronous encoder [RD77MS]	The incremental synchronous encoder that is connected to the manual pulse generator/incremental synchronous encoder input of the Simple Motion module is used as the synchronous encoder axis.
Synchronous encoder via servo amplifier	Used to use a synchronous encoder connected to the servo amplifier which supports the scale measurement mode as a synchronous encoder axis.
Synchronous encoder via CPU	Used to operate a gray code encoder that is connected to the input module of CPU module as a synchronous encoder axis.
Synchronous encoder via link device [RD77GF]	Used to use an incremental synchronous encoder, etc. connected to the high-speed counter module on the CC-Link IE Field Network as a synchronous encoder axis.

Control method for synchronous encoder axis

The following controls can be executed for the synchronous encoder axis by using "[Cd.320] Synchronous encoder axis control start" and "[Cd.321] Synchronous encoder axis control method".

Setting value of "[Cd.321] Synchronous encoder axis control method"	Control details
0: Current value change	"[Md.320] Synchronous encoder axis current value" and "[Md.321] Synchronous encoder axis current value per cycle" are changed based on the setting of "[Cd.322] Synchronous encoder axis current value setting address".
1: Counter disable	Input from the synchronous encoder is disabled.
2: Counter enable	Input from the synchronous encoder is enabled.

Units for the synchronous encoder axis

The position units and speed units for the synchronous encoder axis are shown below for the setting of "[Pr.321] Synchronous encoder axis unit setting".

■ Synchronous encoder axis position units

Setting value of "[Pr.321] Synchronous encoder axis unit setting"		Synchronous encoder axis position unit	Range
Control unit	Number of decimal places for position		
0: mm	0	mm	-2147483648 to 2147483647 [mm]
	⋮	⋮	⋮
	9	$\times 10^{-9}$ mm	-2.147483648 to 2.147483647 [mm]
1: inch	0	inch	-2147483648 to 2147483647 [inch]
	⋮	⋮	⋮
	9	$\times 10^{-9}$ inch	-2.147483648 to 2.147483647 [inch]
2: degree	0	degree	-2147483648 to 2147483647 [degree]
	⋮	⋮	⋮
	9	$\times 10^{-9}$ degree	-2.147483648 to 2.147483647 [degree]
3: pulse	0	pulse	-2147483648 to 2147483647 [pulse]
	⋮	⋮	⋮
	9	$\times 10^{-9}$ pulse	-2.147483648 to 2.147483647 [pulse]

■ Synchronous encoder axis speed units

Setting value of "[Pr.321] Synchronous encoder axis unit setting"			Synchronous encoder axis speed unit	Range
Control unit	Speed time unit	Number of decimal places for speed		
0: mm	0: second [s]	0	mm/s	-2147483648 to 2147483647 [mm/s]
		⋮	⋮	⋮
		9	$\times 10^{-9}$ mm/s	-2.147483648 to 2.147483647 [mm/s]
	1: minute [min]	0	mm/min	-2147483648 to 2147483647 [mm/min]
		⋮	⋮	⋮
		9	$\times 10^{-9}$ mm/min	-2.147483648 to 2.147483647 [mm/min]
1: inch	0: second [s]	0	inch/s	-2147483648 to 2147483647 [inch/s]
		⋮	⋮	⋮
		9	$\times 10^{-9}$ inch/s	-2.147483648 to 2.147483647 [inch/s]
	1: minute [min]	0	inch/min	-2147483648 to 2147483647 [inch/min]
		⋮	⋮	⋮
		9	$\times 10^{-9}$ inch/min	-2.147483648 to 2.147483647 [inch/min]
2: degree	0: second [s]	0	degree/s	-2147483648 to 2147483647 [degree/s]
		⋮	⋮	⋮
		9	$\times 10^{-9}$ degree/s	-2.147483648 to 2.147483647 [degree/s]
	1: minute [min]	0	degree/min	-2147483648 to 2147483647 [degree/min]
		⋮	⋮	⋮
		9	$\times 10^{-9}$ degree/min	-2.147483648 to 2.147483647 [degree/min]
3: pulse	0: second [s]	0	pulse/s	-2147483648 to 2147483647 [pulse/s]
		⋮	⋮	⋮
		9	$\times 10^{-9}$ pulse/s	-2.147483648 to 2.147483647 [pulse/s]
	1: minute [min]	0	pulse/min	-2147483648 to 2147483647 [pulse/min]
		⋮	⋮	⋮
		9	$\times 10^{-9}$ pulse/min	-2.147483648 to 2.147483647 [pulse/min]

Setting method for synchronous encoder

Incremental synchronous encoder [RD77MS]

■Setting method

Connect the synchronous encoder to the "Manual pulse generator/Incremental synchronous encoder input" of the Simple Motion module.

Set the input method for the incremental synchronous encoder signal using the following parameters. (It may be common to use the same set up for the manual pulse generator input.)

- "[Pr.24] Manual pulse generator/Incremental synchronous encoder input selection"
- "[Pr.89] Manual pulse generator/Incremental synchronous encoder input type selection"
- "[Pr.151] Manual pulse generator/Incremental synchronous encoder input logic selection"

Point

The synchronous encoder axis operates completely independently with the manual pulse generator operation. The parameter and control data for the manual pulse generator operation except the 3 parameters listed above has not influence on control of synchronous encoder axis. Therefore, they can also be controlled simultaneously by common input pulses.

When the synchronous encoder axis connection is valid after the system's power supply is ON, it will be "Synchronous encoder axis current value = 0", "Synchronous encoder axis current value per cycle = 0" and "Counter enabling status".

■Setting example

The following shows an example for setting an incremental synchronous encoder as synchronous encoder axis 2 of the Simple Motion module.

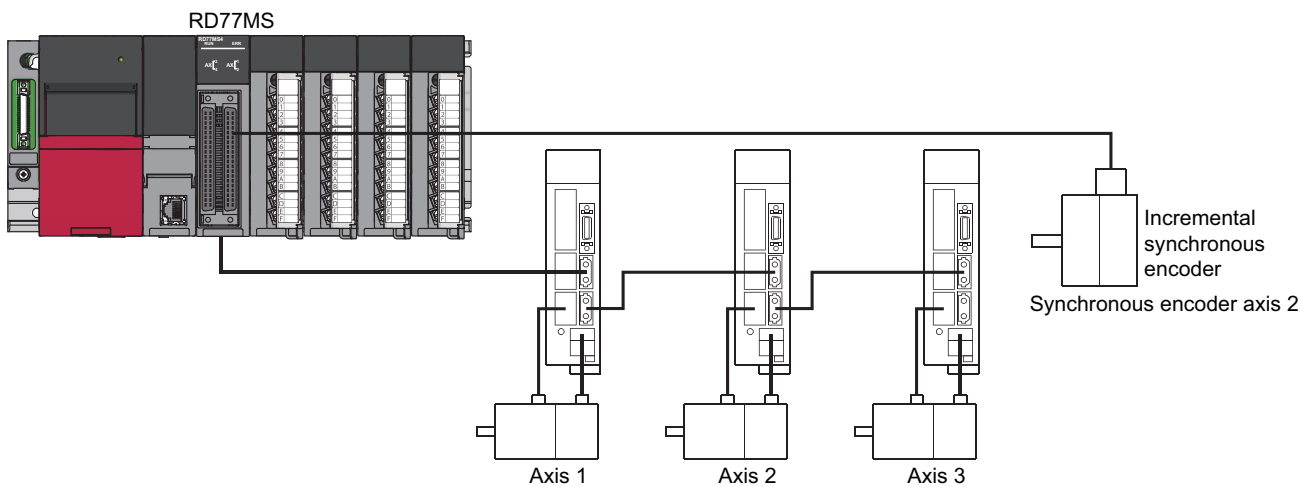

Set "1: Incremental synchronous encoder" in "[Pr.320] Synchronous encoder axis type" for the synchronous encoder axis 2. And, set the input method for incremental synchronous encoder signal in the following parameters.

- "[Pr.24] Manual pulse generator/Incremental synchronous encoder input selection": "0: A-phase/B-phase multiplied by 4"
- "[Pr.89] Manual pulse generator/Incremental synchronous encoder input type selection": "0: Differential output type"
- "[Pr.151] Manual pulse generator/Incremental synchronous encoder input logic selection": "0: Differential output type"

Synchronous encoder via servo amplifier

There are restrictions in the function and the encoder that can be used by the version of the servo amplifier.

■ Setting method

Used to use a synchronous encoder connected to the servo amplifier which supports the scale measurement mode as a synchronous encoder axis.

The following servo amplifiers can be used. The servo amplifier must support the scale measurement function.

- MR-J4-B-RJ [RD77MS]
- MR-J4-GF-RJ [RD77GF]

Only a rotary encoder can be connected. Refer to the following servo amplifier instruction manuals for the version of the servo amplifier which supports the scale measurement function and the rotary encoder which can be used.

📖 SSCNETⅢ/H Interface AC Servo MR-J4-_B_(-RJ) Servo Amplifier Instruction Manual [RD77MS]

📖 CC-Link IE Field Network Interface Servo Amplifier Instruction Manual (Motion Mode) [RD77GF]

A synchronous encoder connected to the specified servo amplifier axis can be used by the following settings.

Setting item	Setting method
Synchronous encoder axis setting	Set "101 to 116: Synchronous encoder via servo amplifier (Connectable servo amplifier: axis 1 to axis 32 ^{*1})" in "[Pr.320] Synchronous encoder axis type". [Setting method of Simple Motion Module Setting Function] Set the synchronous encoder axis parameter according to the setting below. <ul style="list-style-type: none"> • "[Pr.320] Type" 101: Synchronous encoder via servo amplifier <ul style="list-style-type: none"> • "[Pr.320] Axis No. of connected servo amplifier" Axis No. of servo amplifier to connect
Encoder type setting (Absolute/Incremental)	Set the servo parameter "Scale measurement mode selection (PA22)" according to the setting below. <ul style="list-style-type: none"> 0__H: Disabled 1__H: Used in absolute position detection system 2__H: Used in incremental system [Setting method of Simple Motion Module Setting Function] [RD77MS] Set "ABS" or "INC" from the "External synchronous encoder input" list of the amplifier setting dialog. (The amplifier setting dialog can be opened from the "System Configuration" window in the "System Setting".)

*1 The range from axis 1 to 2 is valid in the 2-axis module, from axis 1 to 4 is valid in the 4-axis module, from axis 1 to 8 is valid in the 8-axis module, from axis 1 to 16 is valid in the 16-axis module, and from axis 1 to 32 is valid in the 32-axis module.

When "1__H" is set in the servo parameter "Scale measurement mode selection (PA22)", the synchronous encoder axis current value and the synchronous encoder axis current value per cycle are restored after the servo amplifier axis is connected. Therefore, connection becomes valid, and will be on the counter enabling status. (The current value setting by current value change is required beforehand.)

When "2__H" is set in the servo parameter "Scale measurement mode selection (PA22)", "0" is set to the initial value of the synchronous encoder axis current value and the synchronous encoder axis current value per cycle after the servo amplifier axis is connected. Therefore, connection becomes valid, and will be on the counter enabling status.

If the corresponding servo amplifier axis is not connected, the connection of the synchronous encoder axis will be invalid.

Point

When "1__H" is set in the servo parameter "Scale measurement mode selection (PA22)" and the synchronous encoder movement amount (encoder pulse units) on disconnection or during the power supply OFF exceeds "2147483647" or "-2147483648", the synchronous encoder axis current value is restored with its opposite sign.

■Point of the setting method

- "Scale measurement mode selection (PA22)" is set to the servo amplifier set by "ABS" or "INC" from the "External synchronous encoder input" list of the amplifier setting dialog using the Simple Motion Module Setting Function. [RD77MS]
- When the servo parameter "Scale measurement mode selection (PA22)" is changed, it is required to switch the power of servo amplifier off once after the parameter is transferred to the servo amplifier, and then switch it on again.
- If the servo amplifier set by the servo parameter "Scale measurement mode selection (PA22)" does not support the "Scale measurement mode", "AL.37" (parameter error) will occur in the servo amplifier. Refer to the servo amplifier instruction manual for details of the servo parameter "Scale measurement mode selection (PA22)".
- The synchronous encoder via servo amplifier can be controlled up to 4. However, there is no restriction for the number of connections. Therefore, the error check is not executed even when the external synchronous encoders are set more than 4 in the "System Setting" using the Simple Motion Module Setting Function. [RD77MS]
- The following information of the synchronous encoder via servo amplifier can be output with the optional data monitor. The setting details of the optional data monitor for the synchronous encoder information are shown below. [RD77MS]

Information of synchronous encoder	Setting detail for optional data monitor
Scale position within one-revolution	24: Load side encoder information 1 (Used point: 2words)
Scale absolute counter	25: Load side encoder information 2 (Used point: 2words)

- The following information of the synchronous encoder via servo amplifier can be output with servo cyclic transmission function and servo transient transmission function. For the detail of objects to be set, refer to the manual of the slave device. [RD77GF]

Information of synchronous encoder

Load side encoder information 1

Load side encoder information 2

- A serial absolute synchronous encoder Q171ENC-W8 can be used in an incremental system by setting "2__H" in the servo parameter "Scale measurement mode selection (PA22)" even if the battery of the servo amplifier is dismantled.

■Setting example

The following shows an example for setting a serial absolute synchronous encoder Q171ENC-W8 using MR-J4-B-RJ as synchronous encoder axis 1 of the Simple Motion module.

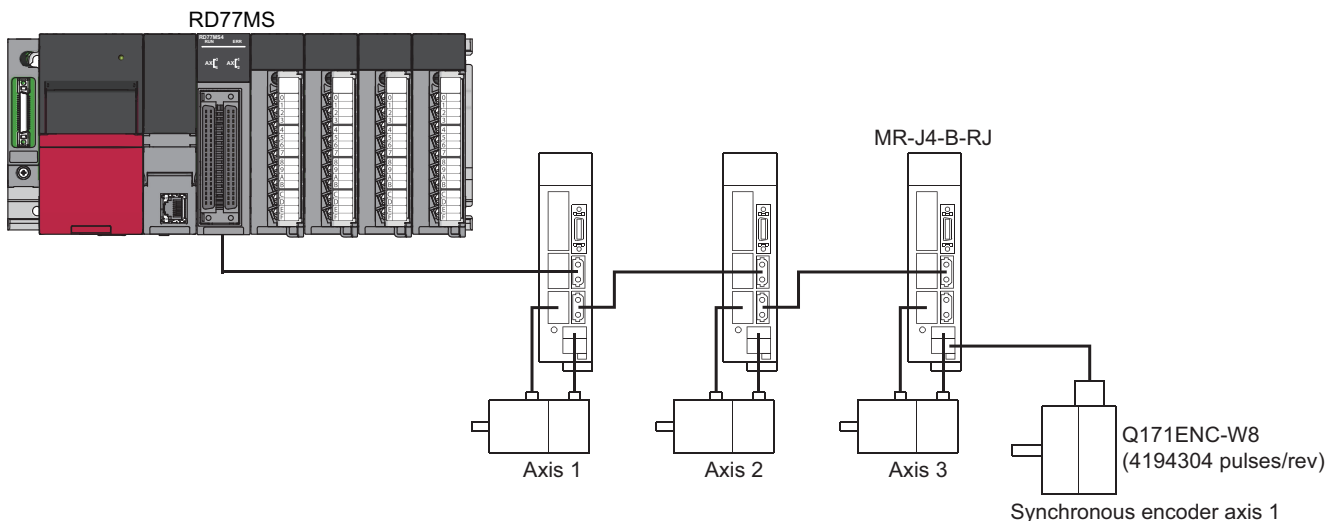

Set the parameters as below.

- Set "101: Synchronous encoder via servo amplifier (servo amplifier axis 3)" in "[Pr.320] Synchronous encoder axis type" of synchronous encoder axis 1.
- Set "MR-J4 series" in "[Pr.100] Connected device" of the axis to connect Q171ENC-W8.
- Set "1__H" or "2__H" in the servo parameter "Scale measurement mode selection (PA22)". (Set "ABS" or "INC" from the "External synchronous encoder input" list of the amplifier setting dialog using the Simple Motion Module Setting Function.) [RD77MS]
- Set "1__H" in the servo parameter "Function selection C-8 (PC26)".

■ Restrictions

- The servo amplifier axis selected as "Synchronous encoder via servo amplifier" in "[Pr.320] Synchronous encoder axis type" does not operate in the fully closed control mode even though "_ _1_H" is set in the servo parameter "Operation mode selection (PA01)".
- The information about the synchronous encoder is output to "[Md.112] Optional data monitor output 4" of the servo amplifier axis selected as "Synchronous encoder via servo amplifier" in "[Pr.320] Synchronous encoder axis type", and "[Pr.94] Optional data monitor: Data type setting 4" is ignored. (Set the total points to be within 3 words for the optional data monitor. Otherwise, the monitor setting is ignored.) [RD77MS]
- When the servo alarms about the serial absolute synchronous encoder connection occur in the servo amplifier axis selected as "Synchronous encoder via servo amplifier" in "[Pr.320] Synchronous encoder axis type", the status becomes servo OFF. "AL.25" (Absolute position erased), "AL.70" (Load-side encoder initial communication error 1), or "AL.71" (Load-side encoder normal communication error 1) occurs in the servo amplifier.
- The error "Synchronous encoder via servo amplifier invalid error" (error code: 1BAAH) occurs in the following cases.

[RD77MS]

- Other than "MR-J4 series" is set in "[Pr.100] Connected device" of the axis No. selected as "Synchronous encoder via servo amplifier" in "[Pr.320] Synchronous encoder axis type".
- The servo amplifier axis which is not set in the system setting is set to the servo amplifier axis No. to connect to "Synchronous encoder via servo amplifier".
- The servo axis, which "Invalid" is set to from the "External synchronous encoder input" list of the amplifier setting dialog using the Simple Motion Module Setting Function, is set to the servo amplifier axis No. to connect to "Synchronous encoder via servo amplifier".
- A linear scale is connected.

[RD77GF]

- The "[Pr.100] Connected device" of the axis No. selected as "Synchronous encoder via servo amplifier" in "[Pr.320] Synchronous encoder axis type" is not set or the servo axis, which scale measurement mode is not enabled, is set to the servo amplifier axis No. to connect to "Synchronous encoder via servo amplifier".
 - A linear scale is connected.
-

Synchronous encoder via CPU (Synchronous encoder via CPU module)

■Setting method

Used to operate a gray code encoder that is connected to the input module of the CPU module as a synchronous encoder axis.

By setting "201: Synchronous encoder via CPU" in "[Pr.320] Synchronous encoder axis type", the synchronous encoder is controlled by the encoder value which is the input value of "[Cd.325] Input value for synchronous encoder via CPU".

The encoder value can be used as a cycle counter within the range from 0 to (Resolution of synchronous encoder via CPU - 1).

Connection is invalid just after the system's power supply is ON. When "1" is set in "[Cd.324] Connection command of synchronous encoder via CPU", the synchronous encoder axis current value and the synchronous encoder axis current value per cycle are restored based on "[Cd.325] Input value for synchronous encoder via CPU". Therefore, connection becomes valid, and will be on the counter enabling status.

The synchronous encoder axis is controlled based on the amount of change of "[Cd.325] Input value for synchronous encoder via CPU" while it is connecting.

■Setting example

The following shows an example for setting a synchronous encoder via CPU as synchronous encoder axis 4 of the Simple Motion module.

(Resolution of the gray code encoder: 4096 pulses/rev)

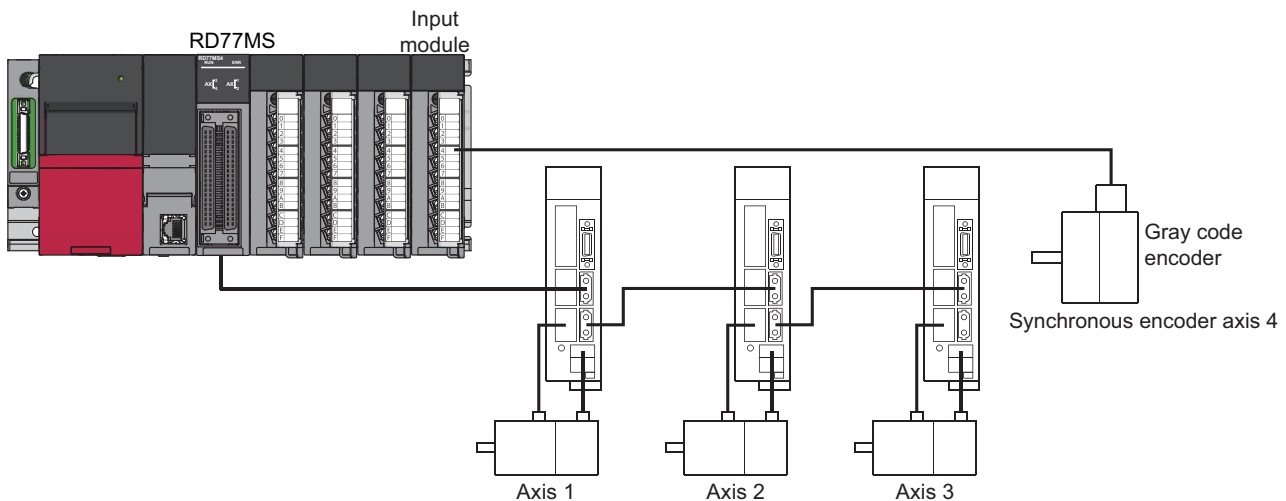

Set "201: Synchronous encoder via CPU" in "[Pr.320] Synchronous encoder axis type" of synchronous encoder axis 4.

Set "4096" in "[Pr.329] Resolution of synchronous encoder via CPU" of synchronous encoder axis 4.

Read the encoder value of the gray code encoder with a program, and update "[Cd.325] Input value for synchronous encoder via CPU" of the synchronous encoder axis 4 at every time.

■ Restrictions

- "[Cd.325] Input value for synchronous encoder via CPU" is taken every operation cycle, but it is asynchronous with the scan time of the CPU module. Therefore, speed fluctuation of the synchronous encoder axis becomes larger if the refresh cycle of "[Cd.325] Input value for synchronous encoder via CPU" becomes long. Update "[Cd.325] Input value for synchronous encoder via CPU" in a cycle less than the operation cycle or use smooth speed fluctuation with the smoothing function.
- The synchronous encoder current value that is restored for the synchronous encoder connection gets restored into a converted value from the following range based on the synchronous encoder movement amount on disconnection.

Setting value of "[Pr.329] Resolution of synchronous encoder via CPU"	Range of restored synchronous encoder current value
1 or more	$-(\text{Resolution of synchronous encoder via CPU} / 2)$ to $(\text{Resolution of synchronous encoder via CPU} / 2 - 1)$ [pulse] ^{*1}
0 or less	-2147483648 to 2147483647 [pulse]

- *1 If the resolution of a synchronous encoder via CPU is an odd number, round down a negative value after the decimal point, round up a positive value after decimal point.

Synchronous encoder via link device [RD77GF]

■Setting method

Used to operate an incremental synchronous encoder that is connected to the high-speed counter module on the CC-Link IE Field Network as a synchronous encoder axis.

By setting "301: Synchronous encoder via link device" in "[Pr.320] Synchronous encoder axis type", the link device assigned to the synchronous encoder input axis can be used by the link device external signal assignment function.

The status is set to the counter disable just after a link is established. The synchronous encoder axis current value and the synchronous encoder axis current value per cycle are restored based on the link device value assigned to the synchronous encoder input axis. Therefore, connection becomes valid.

The synchronous encoder axis is controlled based on the amount of change of the link device value assigned to the synchronous encoder input axis while it is connecting.

■Setting example

The following shows an example for setting a synchronous encoder via link device as synchronous encoder axis 4 of the Simple Motion module.

- Assign the link device to the synchronous encoder input using the link device external signal assignment function.
- Set "301: Synchronous encoder via link device" in "[Pr.320] Synchronous encoder axis type" of synchronous encoder axis 4.

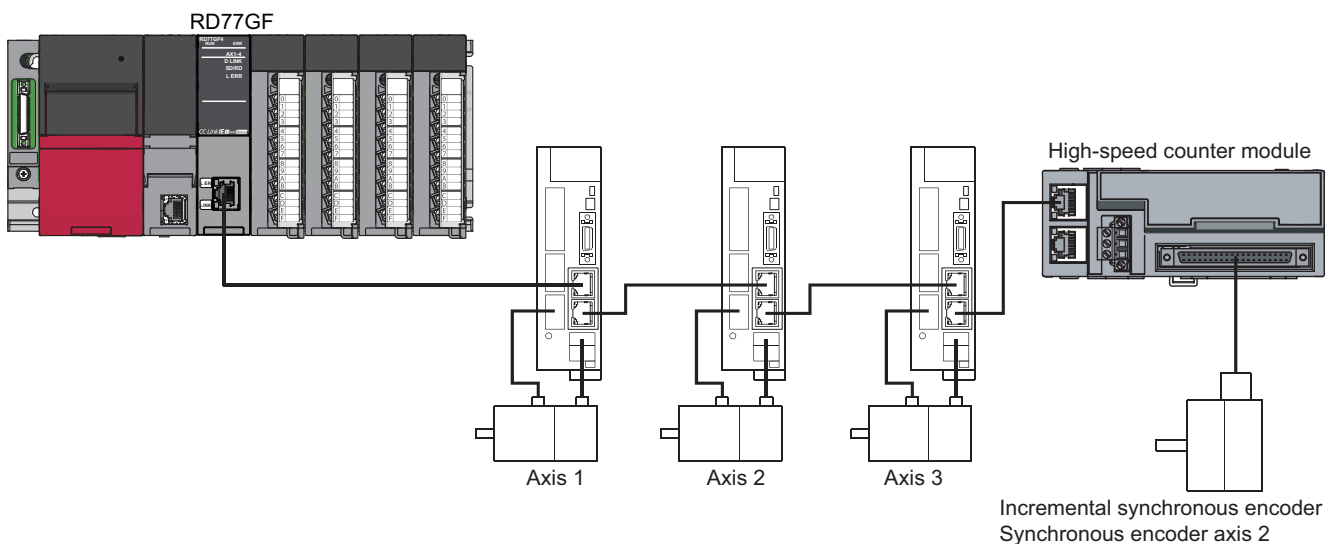

The following shows an example for operating CH1 of the high-speed counter module (NZ2GFCF-D62PD2) as the ring counter to use as synchronous encoder input. For the specification and usage methods of the high-speed counter module, refer to the following manual.

📖 CC-Link IE Field Network High-Speed Counter Module User's Manual

Setting item	Setting value	Setting details
[Pr.710] Synchronous encoder axis: Link device type	0033H	Specify the remote register RWr10 (2 words) which stores the "current value" of the counter module.
[Pr.711] Synchronous encoder axis: Link device start No.	0010H	
[Pr.712] Synchronous encoder axis: Link device count direction setting	0	The encoder current value moves toward the positive direction by the count-up pulse.
[Pr.713] Synchronous encoder axis: Ring counter maximum value	360000	Set the upper limit of the ring counter to 360000. (Set the value to match with the setting value of RWw12 to RWw13.)
[Pr.714] Synchronous encoder axis: Ring counter minimum value	0	Set the lower limit of the ring counter to 0. (Set the value to match with the setting value of RWw10 to RWw11.)

■Restrictions

- When using the link device, the fetch timing of the signal disperses in one link scan cycle.
- Set the movement amount per link scan so that the following formula is satisfied. If not, the actual movement amount of the synchronous encoder and the movement amount counted by the Simple Motion module might not be matched.

$$\text{Movement amount per link scan} < \frac{|(\text{Ring counter maximum value}) - (\text{Ring counter minimum value}) + 1|}{2}$$

Ex.

When using the high-speed counter module shown the setting example above, set the movement amount per link scan to 180000 or less.

$$\text{Movement amount per link scan} < \frac{|360000 - 0 + 1|}{2} = 180000.5$$

Synchronous encoder axis parameters

j: Synchronous encoder axis No. - 1 (j: Axis No. - 17 for axis 17 to axis 32)

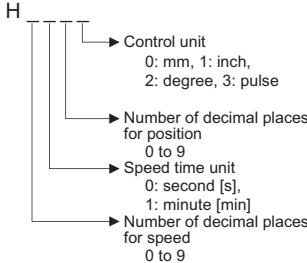
Setting item	Setting details	Setting value	Default value	Buffer memory address	
				Axis 1 to axis 16	Axis 17 to axis 32
[Pr.320] Synchronous encoder axis type	<ul style="list-style-type: none"> Set the synchronous encoder axis type to be used. <p><u>Fetch cycle: At power supply ON</u></p>	<p>■Set in decimal.</p> <p>0: Invalid</p> <p>1: Incremental synchronous encoder [RD77MS]</p> <p>101 to 116: Synchronous encoder via servo amplifier (Connectable servo amplifier: Axis 1 to axis 16^{*1}) [RD77MS]</p> <p>101 to 132: Synchronous encoder via servo amplifier (Connectable servo amplifier: Axis 1 to axis 32^{*1}) [RD77GF]</p> <p>201: Synchronous encoder via CPU</p> <p>301: Synchronous encoder via link device [RD77GF]</p>	0	34720+20j	1034720+20j
[Pr.321] Synchronous encoder axis unit setting	<ul style="list-style-type: none"> Set the unit of the synchronous encoder axis. Set the position unit within the range from $\times 1$ to 10^{-9} [control unit]. Set the speed unit within the range from $\times 1$ to 10^{-9} [control unit/s or control unit/min]. <p><u>Fetch cycle: At power supply ON</u></p>	<p>■Set in hexadecimal.</p> <p>H</p> 	0003H	34721+20j	1034721+20j
[Pr.322] Synchronous encoder axis unit conversion: Numerator	<ul style="list-style-type: none"> Set the numerator to convert the unit from the encoder pulse of the synchronous encoder axis into the synchronous encoder axis unit. <p><u>Fetch cycle: At power supply ON</u></p>	<p>■Set in decimal.</p> <p>-2147483648 to 2147483647</p> <p>[Synchronous encoder axis position units^{*2}]</p>	1	34722+20j 34723+20j	1034722+20j 1034723+20j
[Pr.323] Synchronous encoder axis unit conversion: Denominator	<ul style="list-style-type: none"> Set the denominator to convert the unit from the encoder pulse of the synchronous encoder axis into the synchronous encoder axis unit. <p><u>Fetch cycle: At power supply ON</u></p>	<p>■Set in decimal.</p> <p>1 to 2147483647 [pulse]</p>	1	34724+20j 34725+20j	1034724+20j 1034725+20j
[Pr.324] Synchronous encoder axis length per cycle	<ul style="list-style-type: none"> Set the length per cycle of the synchronous encoder axis. <p><u>Fetch cycle: At power supply ON</u></p>	<p>■Set in decimal.</p> <p>1 to 2147483647</p> <p>[Synchronous encoder axis position units^{*2}]</p>	4000	34726+20j 34727+20j	1034726+20j 1034727+20j
[Pr.325] Synchronous encoder axis smoothing time constant	<ul style="list-style-type: none"> Set the time to smooth for the input value. <p><u>Fetch cycle: At power supply ON</u></p>	<p>■Set in decimal.</p> <p>0 to 5000 [ms]</p>	0	34728+20j	1034728+20j
[Pr.326] Synchronous encoder axis phase compensation advance time	<ul style="list-style-type: none"> Set the time to advance or delay the phase. <p><u>Fetch cycle: Operation cycle</u></p>	<p>■Set in decimal.</p> <p>-2147483648 to 2147483647 [μs]</p>	0	34730+20j 34731+20j	1034730+20j 1034731+20j
[Pr.327] Synchronous encoder axis phase compensation time constant	<ul style="list-style-type: none"> Set the time constant to affect the phase compensation. <p><u>Fetch cycle: At power supply ON</u></p>	<p>■Set in decimal.</p> <p>0 to 65535 [ms]^{*3}</p>	10	34732+20j	1034732+20j
[Pr.328] Synchronous encoder axis rotation direction restriction	<ul style="list-style-type: none"> Set this parameter to restrict the input movement amount to one direction. <p><u>Fetch cycle: At power supply ON</u></p>	<p>■Set in decimal.</p> <p>0: Without rotation direction restriction</p> <p>1: Enable only for current value increase direction</p> <p>2: Enable only for current value decrease direction</p>	0	34733+20j	1034733+20j

Setting item	Setting details	Setting value	Default value	Buffer memory address	
				Axis 1 to axis 16	Axis 17 to axis 32
[Pr.329] Resolution of synchronous encoder via CPU	<ul style="list-style-type: none"> Set the resolution of the synchronous encoder when the synchronous encoder axis type is set to synchronous encoder via CPU. If 0 or less is set, the input value of synchronous encoder via CPU is processed as 32-bit counter. Fetch cycle: At power supply ON	■Set in decimal. -2147483648 to 2147483647 [pulse]	0	34734+20j 34735+20j	1034734+20j 1034735+20j

- *1 The range from axis 1 to 2 is valid in the 2-axis module, from axis 1 to 4 is valid in the 4-axis module, from axis 1 to 8 is valid in the 8-axis module, from axis 1 to 16 is valid in the 16-axis module, and from axis 1 to 32 is valid in the 32-axis module.
- *2 Synchronous encoder axis position units ( Page 36 Synchronous encoder axis position units)
- *3 Set the value as follows in a program.
 0 to 32767: Set as a decimal
 32768 to 65535: Convert into a hexadecimal and set

[Pr.320] Synchronous encoder axis type

Set the synchronous encoder type to be generated of the input value for the synchronous encoder axis.

Setting value	Details
0: Invalid	Synchronous encoder axis is invalid.
1: Incremental synchronous encoder [RD77MS]	Generate the input value based on the incremental synchronous encoder input.
101 to 132: Synchronous encoder via servo amplifier (Connectable servo amplifier: Axis 1 to axis 32 ^{*1})	Generate the input value based on the synchronous encoder input via servo amplifier connected to the specified servo amplifier (axis 1 to axis 32).
201: Synchronous encoder via CPU	Generate the input value with the value set in the buffer memory by the CPU module as the encoder value.
301: Synchronous encoder via link device [RD77GF]	Use an arbitrary value of link device as synchronous encoder input.

- *1 The range from axis 1 to 2 is valid in the 2-axis module, from axis 1 to 4 is valid in the 4-axis module, from axis 1 to 8 is valid in the 8-axis module, from axis 1 to 16 is valid in the 16-axis module, and from axis 1 to 32 is valid in the 32-axis module.

[Pr.321] Synchronous encoder axis unit setting

Set the position and speed unit of the synchronous encoder axis. Refer to the following for details.

 Page 36 Units for the synchronous encoder axis

[Pr.322] Synchronous encoder axis unit conversion: Numerator

The input movement amount of synchronous encoder is configured in encoder pulse units.

The units can be arbitrarily converted through unit conversation with setting [Pr.322] and [Pr.323].

Set [Pr.322] and [Pr.323] according to the controlled machine.

$$\text{Synchronous encoder axis movement amount (Movement amount after unit conversion)} = \frac{\text{Synchronous encoder input movement amount (Encoder pulse units)} \times \text{[Pr.322] Synchronous encoder axis unit conversion: Numerator}}{\text{[Pr.323] Synchronous encoder axis unit conversion: Denominator}}$$

The movement amount corresponding to "[Pr.323] Synchronous encoder axis unit conversion: Denominator" is set in "[Pr.322] Synchronous encoder axis unit conversion: Numerator" in synchronous encoder axis position units ( Page 36 Synchronous encoder axis position units).

The input movement amount can be reversed by the setting negative values. Set "[Pr.323] Synchronous encoder axis unit conversion: Denominator" based on encoder pulse units from the synchronous encoder. Set a value within the range from 1 to 2147483647

[Pr.323] Synchronous encoder axis unit conversion: Denominator

The input movement amount of synchronous encoder is configured in encoder pulse units.

The units can be arbitrarily converted through unit conversation with setting [Pr.322] and [Pr.323].

Set [Pr.322] and [Pr.323] according to the controlled machine.

$$\begin{array}{l} \text{Synchronous encoder axis} \\ \text{movement amount (Movement} \\ \text{amount after unit conversion)} \end{array} = \begin{array}{l} \text{Synchronous encoder input} \\ \text{movement amount} \\ \text{(Encoder pulse units)} \end{array} \times \frac{\text{[Pr.322] Synchronous encoder axis unit conversion: Numerator}}{\text{[Pr.323] Synchronous encoder axis unit conversion: Denominator}}$$

The movement amount corresponding to "[Pr.323] Synchronous encoder axis unit conversion: Denominator" is set in "[Pr.322]

Synchronous encoder axis unit conversion: Numerator" in synchronous encoder axis position units ( Page 36

Synchronous encoder axis position units).

Set "[Pr.323] Synchronous encoder axis unit conversion: Denominator" based on encoder pulse units from the synchronous encoder. Set a value within the range from 1 to 2147483647.

[Pr.324] Synchronous encoder axis length per cycle

Set the length per cycle for the synchronous encoder axis current value per cycle.

The current value of synchronous encoder axis is stored in "[Md.321] Synchronous encoder axis current value per cycle" at ring counter based on the setting value.

The unit settings are in synchronous encoder axis position units ( Page 36 Synchronous encoder axis position units). Set a value within the range from 1 to 2147483647.

Set a value within the range from 1 to 2147483647.

■Setting example of the unit conversion and the length per cycle.

The following shows an example a rotary encoder is connected which resolution is 4000 [pulse/rev] to the motor axis side on the rotation table that drives by 1/5 pulley system, and the control unit is degree.

- Position unit: 0.1 [degree]
- Speed unit: 0.001 [degree/min]
- Length per cycle: 360.0 [degree] (1 cycle of the rotation table)

Setting item	Setting details	Setting value
[Pr.321] Synchronous encoder axis unit setting	Control unit	2: degree
	Number of decimal places for position	1
	Speed time unit	1: minute [min]
	Number of decimal places for speed	3
[Pr.322] Synchronous encoder axis unit conversion: Numerator	360.0 [degree] × 1	3600 [× 0.1 degree]
[Pr.323] Synchronous encoder axis unit conversion: Denominator	4000 [pulse] × 5	20000 [pulse]
[Pr.324] Synchronous encoder axis length per cycle	360.0 [degree]	3600 [× 0.1 degree]

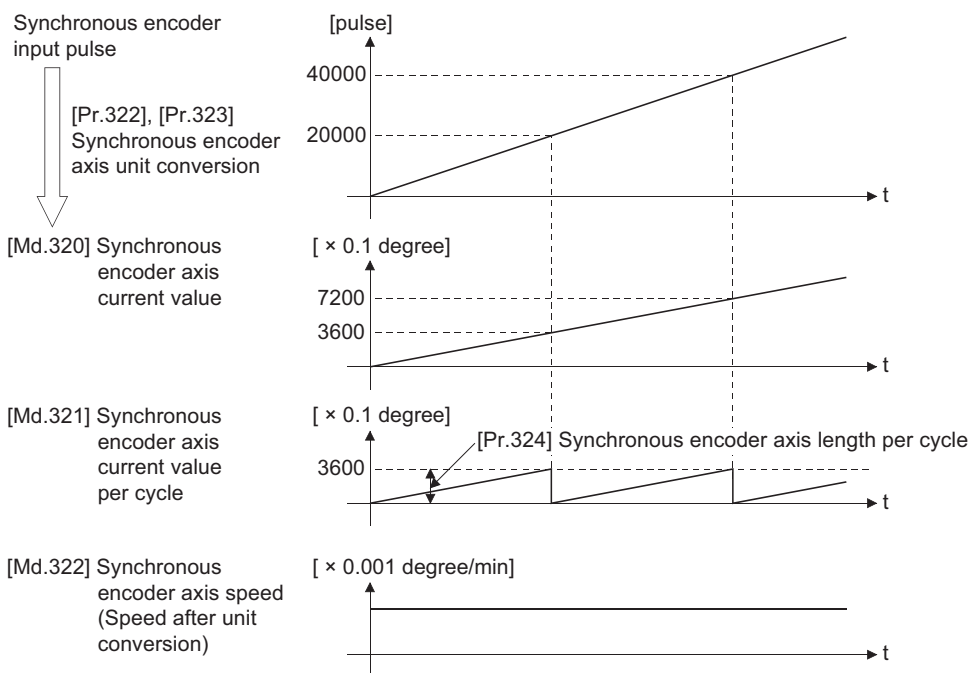

[Pr.325] Synchronous encoder axis smoothing time constant

Set the averaging time to execute a smoothing process for the input movement amount from synchronous encoder.

The smoothing process can moderate speed fluctuation of the synchronous encoder input.

The input response is delayed depending on the time corresponding to the setting by smoothing process setting.

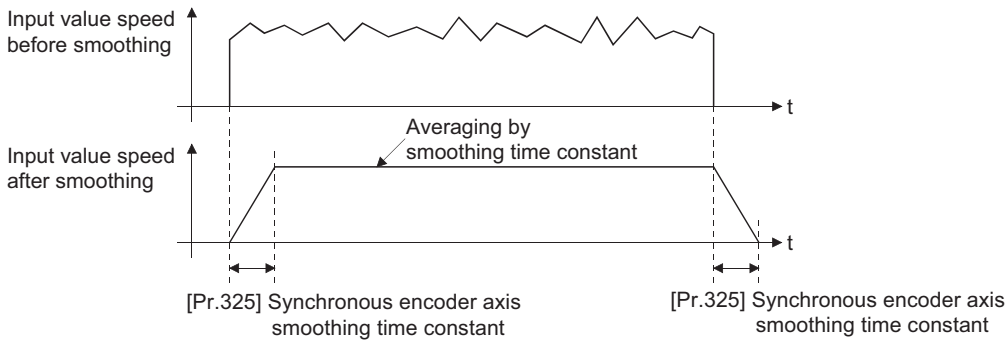

[Pr.326] Synchronous encoder axis phase compensation advance time

Set the time to advance or delay the phase (input response) of the synchronous encoder axis.

Refer to the following for the delay time inherent to the system using the synchronous encoder axis.

☞ Page 140 Phase Compensation Function

Setting value	Details
1 to 2147483647 [μ s]	Advance the phase (input response) according to the setting time.
0 [μ s]	Do not execute phase compensation.
-2147483648 to -1 [μ s]	Delay the phase (input response) according to the setting time.

If the setting time is too long, the system experiences overshoot or undershoot at acceleration/deceleration of the input speed.

In this case, set a longer time to affect the phase compensation amount in "[Pr.327] Synchronous encoder axis phase compensation time constant".

[Pr.327] Synchronous encoder axis phase compensation time constant

Set the time constant to affect the phase compensation amount for the first order delay.

63 [%] of the phase compensation amount are reflected in the time constant setting.

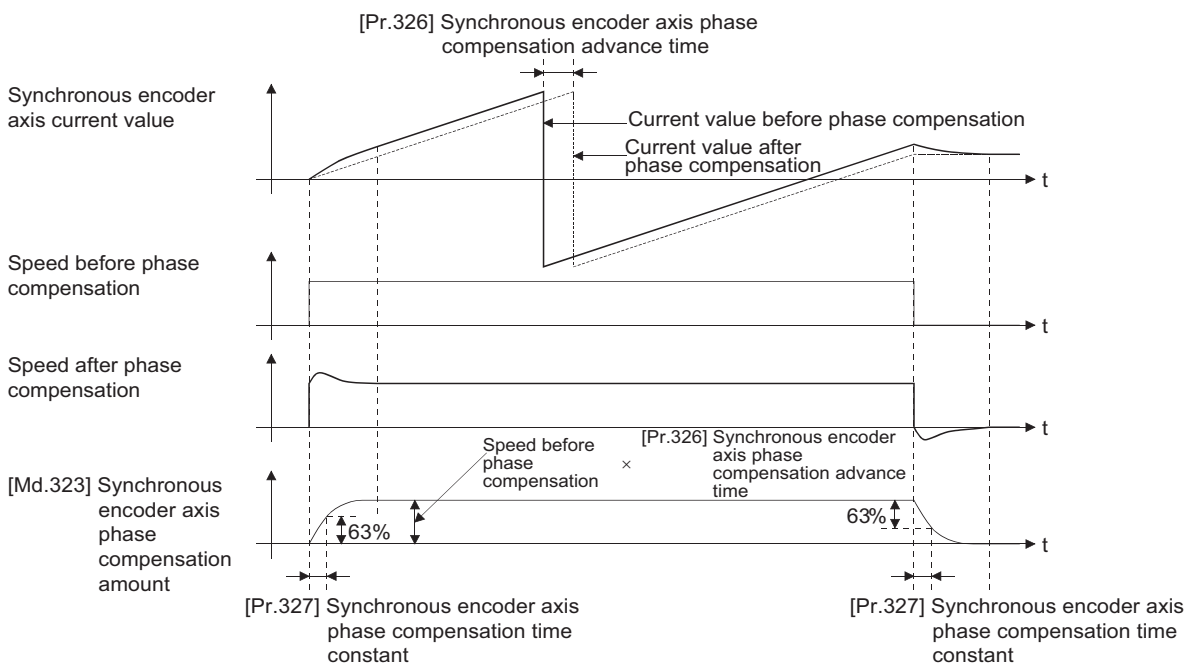

[Pr.328] Synchronous encoder axis rotation direction restriction

Set this parameter to restrict the input movement amount for the synchronous encoder axis to one direction. This helps to avoid reverse operation caused by such as machine vibration of synchronous encoder input.

Setting value	Details
0: Without rotation direction restriction	Rotation direction restriction is not executed.
1: Enable only for current value increase direction	Enable only the input movement amount in the increasing direction of the synchronous encoder axis current value.
2: Enable only for current value decrease direction	Enable only the input movement amount in the decreasing direction of the synchronous encoder axis current value.

The input movement amount in the reverse direction of the enabled direction accumulates as a rotation direction restricted amount, and it will be reflected when the input movement amount moves in the enabled direction again. Therefore, the current value of synchronous encoder axis does not deviate when the reverse operation is repeated.

The rotation direction restricted amount is set to 0 at the synchronous encoder axis connection and current value change.

For "1: Enable only for current value increase direction" is set in "[Pr.328] Synchronous encoder axis rotation direction restriction".

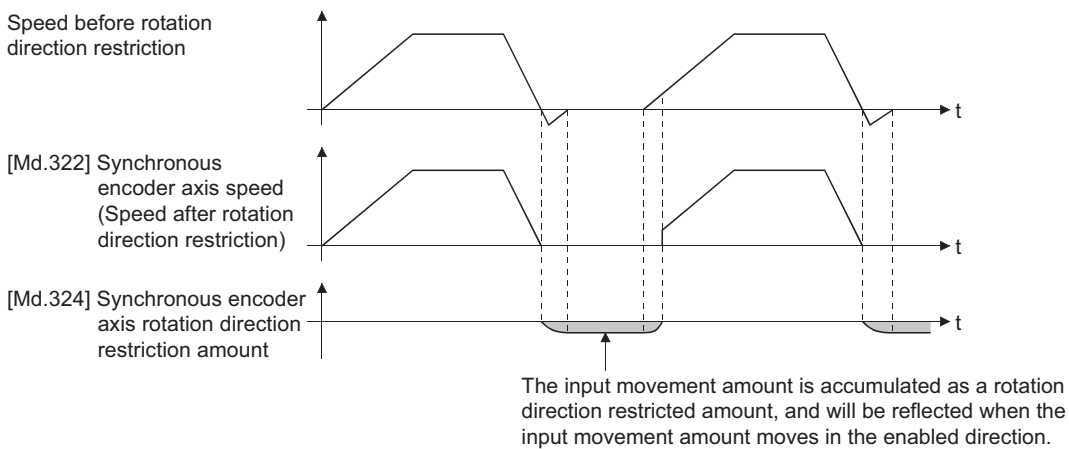

[Pr.329] Resolution of synchronous encoder via CPU

Set the resolution of connected synchronous encoder when "201: Synchronous encoder via CPU" is set in "[Pr.320] Synchronous encoder axis type".

If 1 or more is set, "[Cd.325] Input value for synchronous encoder via CPU" is processed as the cycle counter within the range from 0 to (resolution of synchronous encoder via CPU - 1).

If 0 or less is set, "[Cd.325] Input value for synchronous encoder via CPU" is processed as 32 bit counter within the range from -2147483648 to 2147483647.

Point

If 1 or more is set in "[Pr.329] Resolution of synchronous encoder via CPU", set the cycle counter within the range from 0 to (resolution of synchronous encoder via CPU - 1) as the input value in "[Cd.325] Input value for synchronous encoder via CPU".

Synchronous encoder axis parameters via link device [RD77GF]

j: Synchronous encoder axis No. - 1 (j: Axis No. - 17 for axis 17 to axis 32)

Setting item	Setting details	Setting value	Default value	Buffer memory address	
				Axis 1 to axis 16	Axis 17 to axis 32
[Pr.710] Synchronous encoder axis: Link device type	Set link device type for use. <u>Fetch cycle: At power supply ON</u>	<ul style="list-style-type: none"> ■Set in hexadecimal. Other than below: Invalid 21H: RX (1 word) 22H: RY (1 word) 23H: RWr (1 word) 24H: RWw (1 word) 31H: RX (2 words) 32H: RY (2 words) 33H: RWr (2 words) 34H: RWw (2 words) 	0000H	35520+20j	1035520+20j
[Pr.711] Synchronous encoder axis: Link device start No.	Set link device No. for use. <u>Fetch cycle: At power supply ON</u>	<ul style="list-style-type: none"> ■Set in hexadecimal. 0 to 1FFFH 	0000H	35521+20j	1035521+20j
[Pr.712] Synchronous encoder axis: Link device count direction setting	Set the relationship between link device count direction and assignment signal count direction. (Valid for only 0th bit) <u>Fetch cycle: At power supply ON</u>	<ul style="list-style-type: none"> ■Set in decimal. 0: Plus count (The signal will also be plus counted while the link device is plus count.) 1: Minus count (The signal will be minus counted while the link device is plus count.) 	0	35526+20j	1035526+20j
[Pr.713] Synchronous encoder axis: Ring counter maximum value	Set the relationship between link device count direction and assignment signal count direction. <ul style="list-style-type: none"> • When the ring counter maximum value is equal to the ring counter minimum value, the setting depends on the link device type setting. • When the link device type is a 1-word device and a value outside the range of 1 word is set, the setting is ignored.(-32768 to 32767) 	<ul style="list-style-type: none"> ■Set in decimal. 1 word: -32768 to 32767 2 words: -2147483648 to 2147483647 	0	35522+20j 35523+20j	1035522+20j 1035523+20j
[Pr.714] Synchronous encoder axis: Ring counter minimum value	<ul style="list-style-type: none"> • When the ring counter maximum value is smaller than the ring counter minimum value, the error "Outside the link device maximum/minimum value specification range" (error code: 1CC2H) occurs. <u>Fetch cycle: At power supply ON</u>			35524+20j 35525+20j	1035524+20j 1035525+20j
[Pr.1010] Synchronous encoder axis start request: Link device type	Set link device type for use. <u>Fetch cycle: At power supply ON</u>	<ul style="list-style-type: none"> ■Set in hexadecimal. Other than below: Invalid 11H: RX (1 bit) 12H: RY (1 bit) 13H: RWr (1 bit) 14H: RWw (1 bit) 	0000H	35530+20j	1035530+20j
[Pr.1011] Synchronous encoder axis start request: Link device start No.	Set link device No. for use. <u>Fetch cycle: At power supply ON</u>	<ul style="list-style-type: none"> ■Set in hexadecimal. 0 to 1FFFH 	0000H	35531+20j	1035531+20j
[Pr.1012] Synchronous encoder axis start request: Link device bit specification	Set the bit No. that used in occasion when "13H: RWr (1 bit)" and "14H: RWw (1 bit)" had been set to "[Pr.1010] Link device type". <u>Fetch cycle: At power supply ON</u>	<ul style="list-style-type: none"> ■Set in hexadecimal. 00H to 0FH 	0000H	35532+20j	1035532+20j
[Pr.1013] Synchronous encoder axis start request: Link device logic setting	Set the logic for assignment signal. (Valid for only 0th bit) <u>Fetch cycle: At power supply ON</u>	<ul style="list-style-type: none"> ■Set in decimal. 0: Negative logic 1: Positive logic 	0	35533+20j	1035533+20j

- Set [Pr.710] to [Pr.714] when an arbitrary value of link device is used as synchronous encoder input.
- Set [Pr.1010] to [Pr.1013] when an arbitrary value of link device is used as synchronous encoder axis start request.

[Pr.710] Synchronous encoder axis: Link device type

Set link device type for use.

Other than below: Invalid

21H: RX (1 word)

22H: RY (1 word)

23H: RWr (1 word)

24H: RWw (1 word)

31H: RX (2 words)

32H: RY (2 words)

33H: RWr (2 words)

34H: RWw (2 words)

[Pr.711] Synchronous encoder axis: Link device start No.

Set link device No. for use.

If the link device No. out of the range is set, the error "Outside link device start No. range" (error code: 1CC0H) occurs and the synchronous encoder input via link device cannot be used.

[Pr.712] Synchronous encoder axis: Link device count direction setting

Set the relationship between link device count direction and assignment signal count direction.

(Valid for only 0th bit)

0: Plus count (The signal will also be plus counted while the link device is plus count.)

1: Minus count (The signal will be minus counted while the link device is plus count.)

[Pr.713] Synchronous encoder axis: Ring counter maximum value

Set the maximum value when the link device value is ring counter.

[When the link device type is set to 1 word]

The maximum value: 32767

[When the link device type is set to 2 words]

The maximum value: 2147483647

- When the ring counter maximum value is equal to the ring counter minimum value, the setting depends on the link device type setting.
- When the link device type is a 1-word device and a value outside the range of 1 word is set, the setting is ignored.
- When the ring counter maximum value is smaller than the ring counter minimum value, the error "Outside the link device maximum/minimum value specification range" (error code: 1CC2H) occurs.

[Pr.714] Synchronous encoder axis: Ring counter minimum value

Set the minimum value when the link device value is ring counter.

[When the link device type is set to 1 word]

The minimum value: -32768

[When the link device type is set to 2 words]

The minimum value: -2147483648

- When the ring counter maximum value is equal to the ring counter minimum value, the setting depends on the link device type setting.
- When the link device type is a 1-word device and a value outside the range of 1 word is set, the setting is ignored.
- When the ring counter maximum value is smaller than the ring counter minimum value, the error "Outside the link device maximum/minimum value specification range" (error code: 1CC2H) occurs.

[Pr.1010] Synchronous encoder axis start request: Link device type

Set link device type for use.

Other than below: Invalid

11H: RX (1 bit)

12H: RY (1 bit)

13H: RWr (1 bit)

14H: RWw (1 bit)

[Pr.1011] Synchronous encoder axis start request: Link device start No.

Set link device No. for use.

If the link device No. out of the range is set, the error "Outside link device start No. range" (error code: 1CC0H) occurs and the synchronous encoder axis start via link device cannot be used.

[Pr.1012] Synchronous encoder axis start request: Link device bit specification

Set the bit No. that used in occasion when "13H: RWr (1 bit)" and "14H: RWw (1 bit)" had been set to "[Pr.1010] Link device type".

Setting range: 00H to 0FH

If the value out of the range is set, the error "Outside the link device bit specification range" (error code: 1CC1H) occurs and the synchronous encoder axis start via link device cannot be used.

[Pr.1013] Synchronous encoder axis start request: Link device logic setting

Set the logic for assignment signal.

(Valid for only 0th bit)

0: Negative logic

1: Positive logic

Synchronous encoder axis control data

j: Synchronous encoder axis No. - 1 (j: Axis No. - 17 for axis 17 to axis 32)

Setting item	Setting details	Setting value	Default value	Buffer memory address	
				Axis 1 to axis 16	Axis 17 to axis 32
[Cd.320] Synchronous encoder axis control start	<ul style="list-style-type: none"> If set to "1", the synchronous encoder axis control is started. If set to "101 to 116", the synchronous encoder axis control starts based on the highspeed input request (external command signal). [RD77MS] If set to "201", the synchronous encoder axis control starts based on the synchronous encoder axis control request. [RD77GF] The Simple Motion module resets the value to "0" automatically after completion of the synchronous encoder axis control. <p>Fetch cycle: <u>Operation cycle</u></p>	<p>■Set in decimal.</p> <p>1: Start for synchronous encoder axis control 101 to 116: High-speed input start for synchronous encoder axis control (axis 1 to axis 16^{*2}) [RD77MS] 201: Start request for synchronous encoder axis control (link device) [RD77GF]</p>	0	35040+10j	1035040+10j
[Cd.321] Synchronous encoder axis control method	<ul style="list-style-type: none"> Set the control method for the synchronous encoder axis <p>Fetch cycle: <u>At synchronous encoder axis control start</u></p>	<p>■Set in decimal.</p> <p>0: Current value change 1: Counter disable 2: Counter enable</p>	0	35041+10j	1035041+10j
[Cd.322] Synchronous encoder axis current value setting address	<ul style="list-style-type: none"> Set a new current value for changing the current value. <p>Fetch cycle: <u>At synchronous encoder axis control start</u></p>	<p>■Set in decimal.</p> <p>-2147483648 to 2147483647 [Synchronous encoder axis position units^{*3}]</p>	0	35042+10j 35043+10j	1035042+10j 1035043+10j
[Cd.323] Synchronous encoder axis error reset	<ul style="list-style-type: none"> If set to "1" for resetting error and warning for the synchronous encoder axis, the error No. and warning No. are set to 0, and the error detection and warning detection bits status are turned OFF. The Simple Motion module resets the value to "0" automatically after completion of the error reset. In the case of the synchronous encoder axis parameter error, even if the error is reset, the setting valid flag of the synchronous encoder axis status has been OFF. <p>Fetch cycle: <u>Main cycle</u>^{*1}</p>	<p>■Set in decimal.</p> <p>1: Error reset request</p>	0	35044+10j	1035044+10j
[Cd.324] Connection command of synchronous encoder via CPU	<ul style="list-style-type: none"> If set to "1", the synchronous encoder via CPU is connected. If set to "0", the synchronous encoder via CPU is disconnected. <p>Fetch cycle: <u>Main cycle</u>^{*1}</p>	<p>■Set in decimal.</p> <p>1: Connect synchronous encoder via CPU 0: Disconnect synchronous encoder via CPU</p>	0	35045+10j	1035045+10j
[Cd.325] Input value for synchronous encoder via CPU	<ul style="list-style-type: none"> Set a value to be used every time as the input value for the synchronous encoder for the synchronous encoder via CPU. <p>Fetch cycle: <u>Operation cycle</u></p>	<p>■Set in decimal.</p> <p>-2147483648 to 2147483647 [pulse]</p>	0	35046+10j 35047+10j	1035046+10j 1035047+10j

*1 With the exception of positioning control, main cycle processing is executed during the next available time. It changes by status of axis start.

*2 The range from axis 1 to 2 is valid in the 2-axis module, from axis 1 to 4 is valid in the 4-axis module, from axis 1 to 8 is valid in the 8-axis module, and from axis 1 to 16 is valid in the 16-axis module.

*3 Synchronous encoder axis position units ( Page 36 Synchronous encoder axis position units)

[Cd.320] Synchronous encoder axis control start

If set to "1", the synchronous encoder axis control is started.

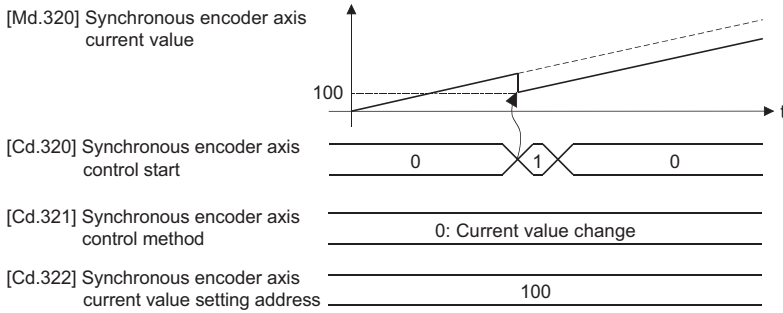

[RD77MS]

If set to "101 to 116", the synchronous encoder axis control starts based on the high-speed input request [DI] for the specified servo amplifier axis.

Set "4: High speed input request" in "[Pr.42] External command function selection" and set "1: Validates an external command" in "[Cd.8] External command valid" for the specified servo amplifier axis to start from a high speed input request [DI]. Also, set the external command signal to be used in "[Pr.95] External command signal selection".

Set the control method for the synchronous encoder axis in "[Cd.321] Synchronous encoder axis control method".

The Simple Motion module resets the value to "0" automatically after completion of the synchronous encoder axis control.

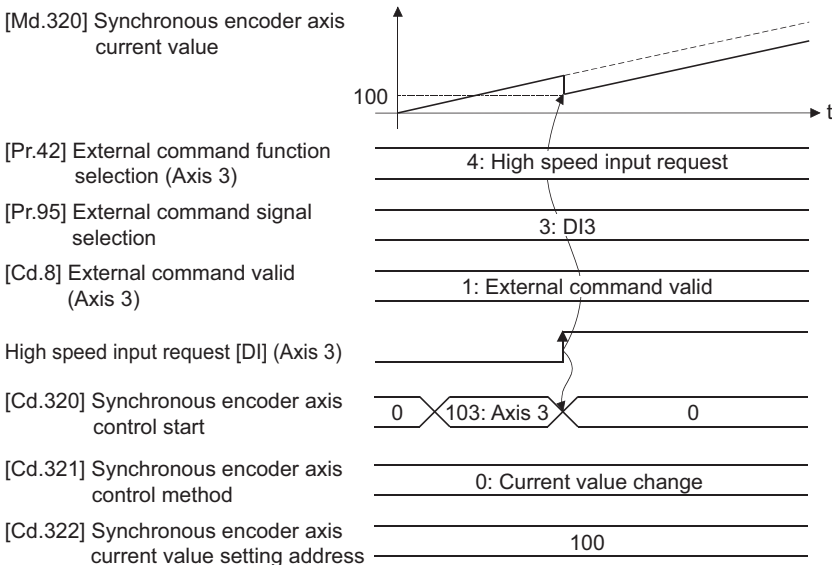

[RD77GF]

If set to "201", the synchronous encoder axis control starts based on the link device input assigned to the synchronous encoder axis start request by the link device external signal assignment function.

Set the control method for the synchronous encoder axis in "[Cd.321] Synchronous encoder axis control method".

The Simple Motion module resets the value to "0" automatically after completion of the synchronous encoder axis control.

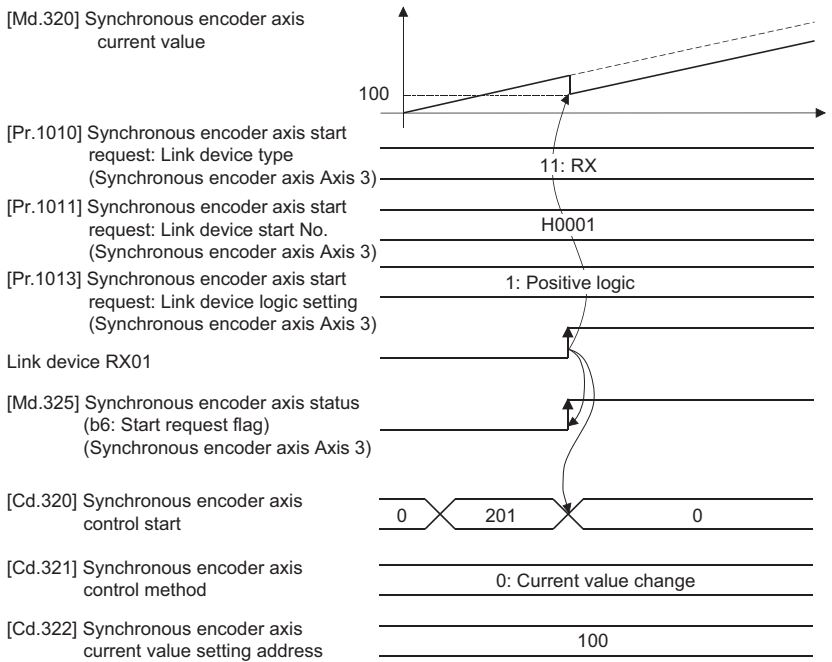

[Cd.321] Synchronous encoder axis control method

Set the control method for the synchronous encoder axis.

Setting value	Details	
0: Current value change	The synchronous encoder axis current value and the synchronous encoder axis current value per cycle are changed as follows. Set the new current value in "[Cd.322] Synchronous encoder axis current value setting address".	
	[Md.320] Synchronous encoder axis current value	"[Cd.322] Synchronous encoder axis current value setting address"
	[Md.321] Synchronous encoder axis current value per cycle	A value that is converted "[Cd.322] Synchronous encoder axis current value setting address" into the range from 0 to "[Pr.324] Synchronous encoder axis length per cycle - 1".
1: Counter disable	Input from the synchronous encoder is invalid. Smoothing processing, phase compensation processing and rotation direction restriction processing are continued. While these processes are valid, the input axis speed may not stop immediately when the counter disable is selected.	
2: Counter enable	Input from the synchronous encoder is valid.	

[Cd.322] Synchronous encoder axis current value setting address

Set a new current value in synchronous encoder axis position units to apply to the current value change for the synchronous encoder axis (👉 Page 36 Synchronous encoder axis position units).

[Cd.323] Synchronous encoder axis error reset

If set to "1", "[Md.326] Synchronous encoder axis error No." and "[Md.327] Synchronous encoder axis warning No." are set to 0 and then "b4: Error detection flag" and "b5: Warning detection flag" of "[Md.325] Synchronous encoder axis status" are turned OFF. A synchronous encoder connection becomes valid if there is no error.

The Simple Motion module resets the value to "0" automatically after completion of the error reset.

However, the setting of the synchronous encoder axis will not be valid even if the error is reset for the setting error of the synchronous encoder axis parameter. Reconfigure the parameter and turn the power supply ON again.

[Cd.324] Connection command of synchronous encoder via CPU

Use this data when "201: Synchronous encoder via CPU" is set in "[Pr.320] Synchronous encoder axis type".

If set to "1", the synchronous encoder axis is connected. Once connected, the synchronous encoder current value is restored based on the "[Cd.325] Input value for synchronous encoder via CPU".

If set to "0", the synchronous encoder axis is disconnected.

[Cd.325] Input value for synchronous encoder via CPU

Use this data when "201: Synchronous encoder via CPU" is set in "[Pr.320] Synchronous encoder axis type".

Set a value to be used every time as the input value for the synchronous encoder in encoder pulse units.

If 1 or more is set in "[Pr.329] Resolution of synchronous encoder via CPU", it is processed as a cycle counter within the range from 0 to (resolution of synchronous encoder via CPU - 1).

Synchronous encoder axis monitor data

j: Synchronous encoder axis No. - 1 (j: Axis No. - 17 for axis 17 to axis 32)

Monitor item	Storage details	Monitor value	Buffer memory address																																
			Axis 1 to axis 16	Axis 17 to axis 32																															
[Md.320] Synchronous encoder axis current value	<ul style="list-style-type: none"> The current value for the synchronous encoder axis is stored. <u>Refresh cycle: Operation cycle</u>	<ul style="list-style-type: none"> Monitoring is carried out in decimal. -2147483648 to 2147483647 [Synchronous encoder axis position units^{*1}] 	35200+20j 35201+20j	1035200+20j 1035201+20j																															
[Md.321] Synchronous encoder axis current value per cycle	<ul style="list-style-type: none"> The current value per cycle for a synchronous encoder axis is stored. <u>Refresh cycle: Operation cycle</u>	<ul style="list-style-type: none"> Monitoring is carried out in decimal. 0 to (Synchronous encoder axis length per cycle - 1) [Synchronous encoder axis position units^{*1}] 	35202+20j 35203+20j	1035202+20j 1035203+20j																															
[Md.322] Synchronous encoder axis speed	<ul style="list-style-type: none"> The speed for a synchronous encoder axis is stored. <u>Refresh cycle: Operation cycle</u>	<ul style="list-style-type: none"> Monitoring is carried out in decimal. -2147483648 to 2147483647 [Synchronous encoder axis speed units^{*2}] 	35204+20j 35205+20j	1035204+20j 1035205+20j																															
[Md.323] Synchronous encoder axis phase compensation amount	<ul style="list-style-type: none"> The current phase compensation amount is stored. <u>Refresh cycle: Operation cycle</u>	<ul style="list-style-type: none"> Monitoring is carried out in decimal. -2147483648 to 2147483647 [Synchronous encoder axis position units^{*1}] 	35206+20j 35207+20j	1035206+20j 1035207+20j																															
[Md.324] Synchronous encoder axis rotation direction restriction amount	<ul style="list-style-type: none"> While the rotation direction is restricted, the accumulation for the input movement amount in the opposite direction of the enabled direction is stored. <u>Refresh cycle: Operation cycle</u>	<ul style="list-style-type: none"> Monitoring is carried out in decimal. -2147483648 to 2147483647 [Synchronous encoder axis position units^{*1}] 	35208+20j 35209+20j	1035208+20j 1035209+20j																															
[Md.325] Synchronous encoder axis status	<ul style="list-style-type: none"> The status for a synchronous encoder axis is monitored. <u>Refresh cycle: Operation cycle</u>	<ul style="list-style-type: none"> Monitoring is carried out in hexadecimal. <p>Buffer memory</p> <table border="1"> <tr> <td>b15</td><td>b12</td><td>b8</td><td>b4</td><td>b0</td> </tr> <tr> <td>□</td><td>□</td><td>□</td><td>□</td><td>□</td> </tr> <tr> <td colspan="5">Not used</td> </tr> </table> <table border="1"> <thead> <tr> <th>Stored items</th> <th>Meaning</th> </tr> </thead> <tbody> <tr> <td>b0</td> <td>Setting valid flag</td> </tr> <tr> <td>b1</td> <td>Connecting valid flag</td> </tr> <tr> <td>b2</td> <td>Counter enable flag</td> </tr> <tr> <td>b3</td> <td>Current value setting request flag</td> </tr> <tr> <td>b4</td> <td>Error detection flag</td> </tr> <tr> <td>b5</td> <td>Warning detection flag</td> </tr> <tr> <td>b6</td> <td>Start request flag [RD77GF]</td> </tr> </tbody> </table> <p>0: OFF 1: ON</p>	b15	b12	b8	b4	b0	□	□	□	□	□	Not used					Stored items	Meaning	b0	Setting valid flag	b1	Connecting valid flag	b2	Counter enable flag	b3	Current value setting request flag	b4	Error detection flag	b5	Warning detection flag	b6	Start request flag [RD77GF]	35210+20j	1035210+20j
b15	b12	b8	b4	b0																															
□	□	□	□	□																															
Not used																																			
Stored items	Meaning																																		
b0	Setting valid flag																																		
b1	Connecting valid flag																																		
b2	Counter enable flag																																		
b3	Current value setting request flag																																		
b4	Error detection flag																																		
b5	Warning detection flag																																		
b6	Start request flag [RD77GF]																																		
[Md.326] Synchronous encoder axis error No.	<ul style="list-style-type: none"> The error code for the synchronous encoder axis is stored. <u>Refresh cycle: Operation cycle</u>	<ul style="list-style-type: none"> Monitoring is carried out in hexadecimal. (MELSEC iQ-R Simple Motion Module User's Manual (Application)) 	35211+20j	1035211+20j																															
[Md.327] Synchronous encoder axis warning No.	<ul style="list-style-type: none"> The warning code for the synchronous encoder axis is stored <u>Refresh cycle: Operation cycle</u>	<ul style="list-style-type: none"> Monitoring is carried out in hexadecimal. (MELSEC iQ-R Simple Motion Module User's Manual (Application)) 	35212+20j	1035212+20j																															

*1 Synchronous encoder axis position units (Page 36 Synchronous encoder axis position units)

*2 Synchronous encoder axis speed units (Page 37 Synchronous encoder axis speed units)

[Md.320] Synchronous encoder axis current value

The current value for the synchronous encoder axis is stored in synchronous encoder axis position units (Page 36 Synchronous encoder axis position units).

The synchronous encoder position for an incremental synchronous encoder is "0" immediately after the power supply ON.

[Md.321] Synchronous encoder axis current value per cycle

The current value per cycle for a synchronous encoder axis is stored in the range from 0 to ("[Pr.324] Synchronous encoder axis length per cycle" - 1).

The unit is synchronous encoder axis position units (Page 36 Synchronous encoder axis position units).

[Md.322] Synchronous encoder axis speed

The speed for a synchronous encoder axis is stored in synchronous encoder axis speed units ( Page 37 Synchronous encoder axis speed units).

If the speed for a synchronous encoder axis exceeds the monitor range ( Page 35 Overview of synchronous encoder axis), the warning "Input axis speed display over" (warning code: 0BD2H) will occur. In this case, use a smaller number of decimal places for the speed in "[Pr.321] Synchronous encoder axis unit setting" or set the speed time units to "0: second [s]".

[Md.323] Synchronous encoder axis phase compensation amount

The phase compensation amount for a synchronous encoder axis is stored in the synchronous encoder axis position units ( Page 36 Synchronous encoder axis position units).

The phase compensation amount for a synchronous encoder axis is the value after smoothing processing and phase compensation processing.

[Md.324] Synchronous encoder axis rotation direction restriction amount

While the rotation direction is restricted for a synchronous encoder axis, the accumulation for input movement amount in the opposite direction of the enabled direction is stored in synchronous encoder axis position units ( Page 36 Synchronous encoder axis position units) as follows.

Setting value of "[Pr.328] Synchronous encoder axis rotation direction restriction"	Storage details
1: Enable only for current value increase direction	A negative accumulation is stored during rotation direction restriction. 0 is stored if there is no restriction.
2: Enable only for current value decrease direction	A positive accumulation is stored during rotation direction restriction. 0 is stored if there is no restriction.

Rotation direction restriction is processed after phase compensation processing. Therefore, if undershoot occurs from phase compensation during deceleration stop, the rotation direction restriction amount might remain.

[Md.325] Synchronous encoder axis status

The each status for a synchronous encoder axis is monitored with the following each bits.

Bit	Storage item	Storage details
b0	Setting valid flag	At power supply ON, this flag turns ON when the synchronous encoder axis parameter ([Pr.320] to [Pr.329]) is normal and the setting of the synchronous encoder axis is valid. It is turned OFF when the setting is invalid or an error occurs.
b1	Connecting valid flag	When the synchronous encoder axis setting is valid, the synchronous encoder connection also becomes valid and this flag turns ON. This flag turns OFF when the connection is invalid. When setting an incremental synchronous encoder, this flag turns ON simultaneously the power supply turns ON regardless of connecting the current encoder.
b2	Counter enable flag	This flag turns ON when input from the synchronous encoder is enabled. If the counter disable control ^{*1} is executed, it is turned OFF, and input from the synchronous encoder becomes invalid. If the counter enable control ^{*1} is executed, it is turned ON, and input from the synchronous encoder becomes valid. When the synchronous encoder is valid to connect, the initial status is ON (enable) status.
b3	Current value setting request flag	This flag turns ON, when a synchronous encoder axis current value change is never executed. If the current value setting request flag is ON for the synchronous encoder connection, the synchronous encoder axis current value starts counting with 0. This flag turns OFF when a synchronous encoder axis current value change is executed.
b4	Error detection flag	This flag turns ON when an error occurs for the synchronous encoder axis. The error No. is stored in "[Md.326] Synchronous encoder axis error No." Reset the error in "[Cd.323] Synchronous encoder axis error reset".
b5	Warning detection flag	This flag turns ON when a warning occurs for the synchronous encoder axis. The warning No. is stored in "[Md.327] Synchronous encoder axis warning No." Reset the warning in "[Cd.323] Synchronous encoder axis error reset".
b6	Start request flag [RD77GF]	This flag turns ON when the link device is assigned to the synchronous encoder axis start request signal and the start is requested.
b7 to b15	Not used	Always OFF

*1 Set the control method for synchronous encoder in "[Cd.321] Synchronous encoder axis control method". ( Page 55 Synchronous encoder axis control data)

[Md.326] Synchronous encoder axis error No.

When an error for a synchronous encoder axis is detected, the error code corresponding to the error details is stored. If set to "1" in "[Cd.323]Synchronous encoder axis error reset", the value is set to "0".

[Md.327] Synchronous encoder axis warning No.

When a warning for a synchronous encoder axis is detected, the warning code corresponding to the warning details is stored. If set to "1" in "[Cd.323] Synchronous encoder axis error reset", the value is set to "0".

3 CAM FUNCTION

The details on cam data and operation for cam function in output axis (cam axis) are explained in this chapter.

The cam function controls output axis by creating cam data that corresponds to the operation.

The functions to operate cam data include "Cam data operation function", "Cam auto-generation function", and "Cam position calculation function".

Refer to the following for the setting of the output axis.

☞ Page 91 ADVANCED SYNCHRONOUS CONTROL

Refer to the following for the cam position calculation function.

☞ Page 162 Cam Position Calculation Function

3.1 Control Details for Cam Function

The output axis for synchronous control is operated with a cam.

The following operations can be performed with cam functions.

- Two-way operation: Reciprocating operation with a constant cam strokes range.
- Feed operation: Cam reference position is updated every cycle.
- Linear operation: Linear operation (cam No.0) in the cycle as the stroke ratio is 100%.

The output axis is controlled by a value (feed current value), which is converted from the input value (cam axis current value per cycle) by cam data.

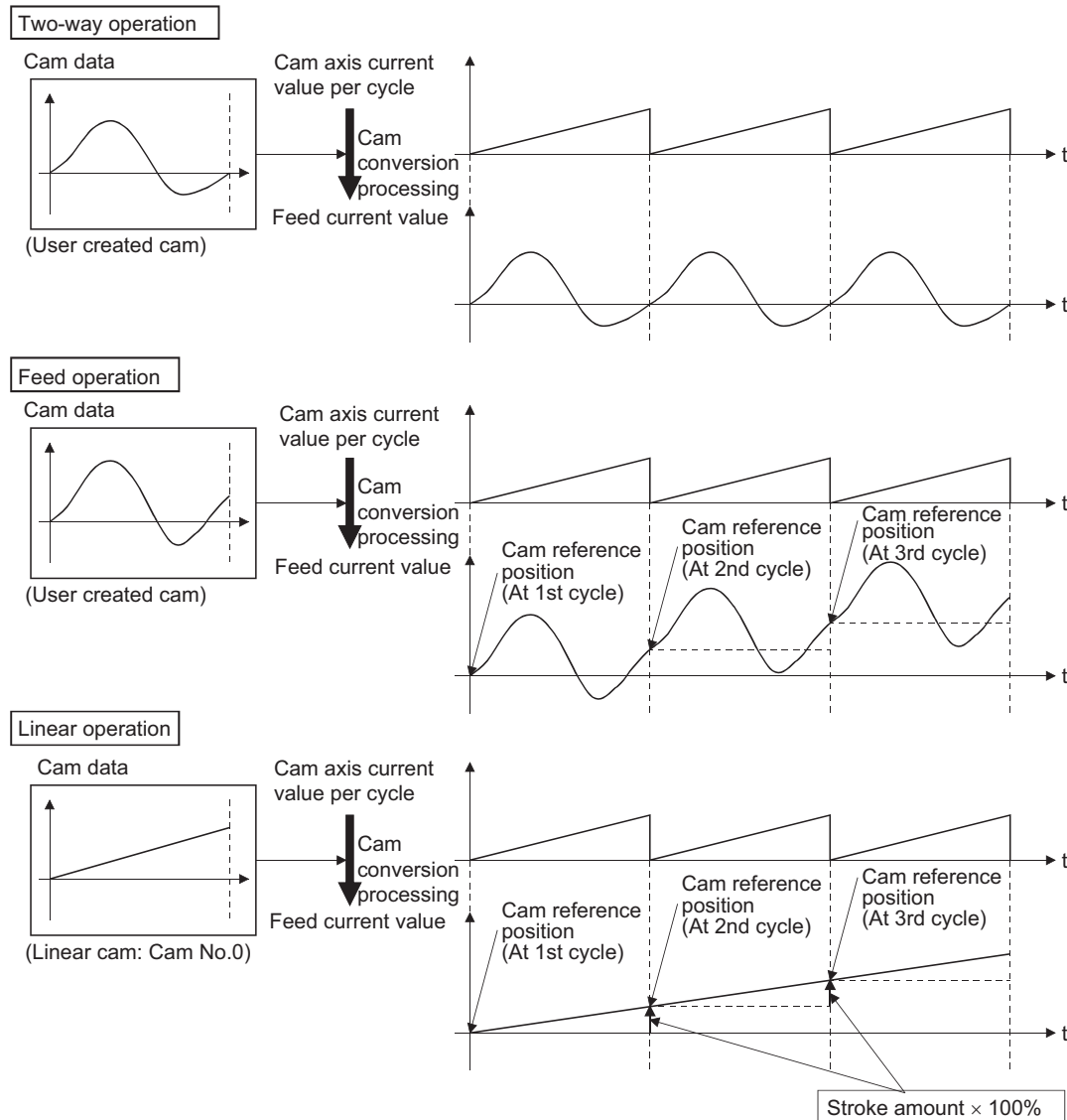

Cam data

The cam data used in the cam function includes "storage data" which is used for reading/writing with the engineering tool and "open data" which is transmitted to the internal memory at cam control.

Storage data		Open data
— (Reading and writing not possible)		Linear cam
Stroke ratio data format		Stroke ratio data format
Auto-generation data format	Cam for rotary cutter [RD77MS]	
	Cam for rotary cutter (central reference) [RD77GF]	
	Easy/Advanced stroke ratio cam [RD77GF]	
Coordinate data format		Coordinate data format

Storage data and open data are same for cams using the stroke ratio data format and the coordinate data format. A cam using the auto-generation data format (storage data) operates after being changed (transmitted) to the stroke ratio data format.

- Data read/written with the engineering tool [RD77MS]

To re-edit the cam data read from the Simple Motion module with the engineering tool, read/write both of "cam data (edit data)" and "cam data (converted data)" when reading/writing the cam data. If only "cam data (conversion data)" is read/written, re-edition may not be executed or the information such as units and strokes may be missed.

■Linear cam control

When "0" is set for "[Pr.440] Cam No.", the cam data operates as a straight line with a 100% stroke ratio at the last point. The linear cam does not consume the cam open area. Also, it cannot be read/written as storage data.

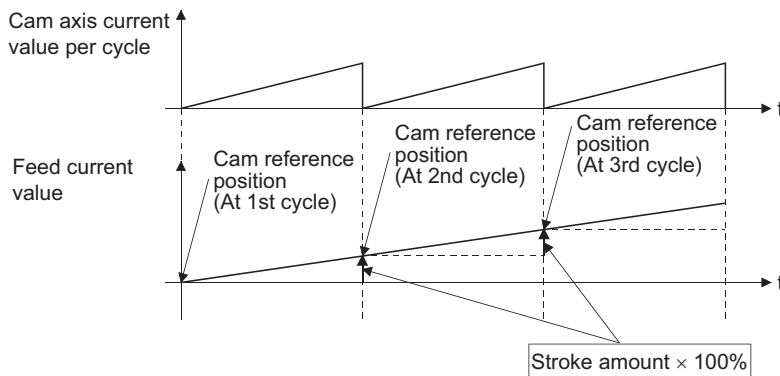

■Stroke ratio data format

The stroke ratio data format is defined in equal divisions for one cam cycle based on the cam resolution, and configured with stroke ratio data from points within the cam resolution.

Refer to the following for setting methods for cam data.

☞ Page 69 Create Cam Data

Setting item	Setting details	Setting range	Default value (Engineering tool)	Cam data operation function
Cam No.	Set the cam No.	0: Linear cam 1 to 256: User created cam [RD77MS] 1 to 1024: User created cam [RD77GF]	1	[Cd.601] Operation cam No.
Cam data format	Set "1". (Setting with the engineering tool is not required.)	1: Stroke ratio data format	1	[Cd.604] Cam data format
Cam resolution	Set the number of divisions for one cam cycle.	256/512/1024/2048/ 4096/8192/16384/ 32768	256	[Cd.605] Cam resolution/ coordinate number
Cam data starting point	Set the cam data point corresponding to "Cam axis current value per cycle = 0".	0 to (Cam resolution - 1)	0	[Cd.606] Cam data starting point
Stroke ratio data	Set the stroke ratio from the 1st to the last point. (The 0th point setting is not required. It is always 0%.)	-2147483648 to 2147483647 [$\times 10^{-7}\%$] ^{*1} (-214.7483648 to 214.7483647%)	0	[Cd.607] Cam data value

*1 To display the stroke ratio out of range $\pm 100\%$, select the "Simple Motion" of "Intelligent Function Module" and set "Yes" to the "Display Extended Stroke of Cam Graph" on the "Options" window displayed by the menu bar of the engineering tool [Tool] ⇒ [Options].

Ex.

Cam resolution: 512

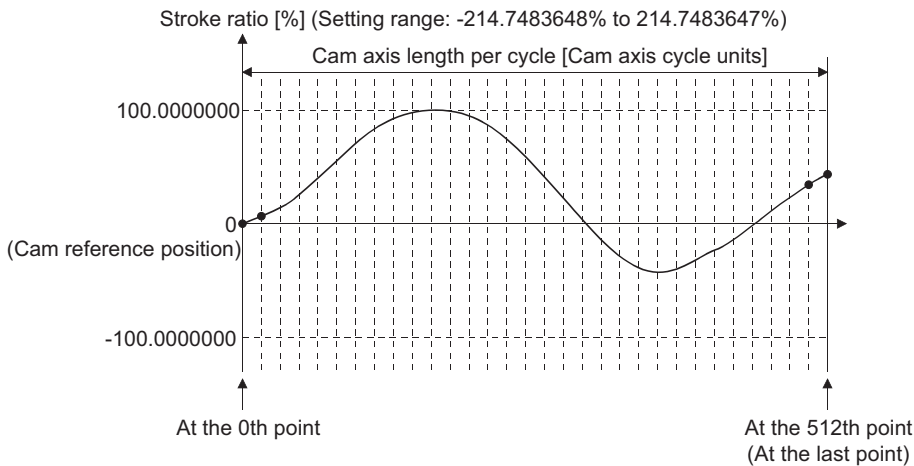

Coordinate data format

The coordinate data format is defined in coordinates of more than 2 points for one cam cycle. The coordinate data is represented as "(Input value, Output value)".

Input value: Cam axis current value per cycle

Output value: Stroke position from cam reference position

With this format, "[Pr.441] Cam stroke amount" of output axis parameter is ignored and output value of the coordinate data becomes cam stroke position.

Refer to the following for setting methods for cam data.

Page 69 Create Cam Data

Setting item	Setting details	Setting range	Default value (Engineering tool)	Cam data operation function
Cam No.	Set the cam No.	0: Linear cam 1 to 256: User created cam [RD77MS] 1 to 1024: User created cam [RD77GF]	1	[Cd.601] Operation cam No.
Cam data format	Set "2". (Setting with the engineering tool is not required.)	2: Coordinate data format	2	[Cd.604] Cam data format
Coordinate number	Set the number of coordinate points in one cam cycle. The coordinates are included at the 0th point.	2 to 16384 [RD77MS] 2 to 65535 [RD77GF]	2	[Cd.605] Cam resolution/ coordinate number
Cam data starting point	Setting is not required with coordinate data format.	—	—	[Cd.606] Cam data starting point
Coordinate data	Set all coordinate data (input value: X_n , output value: Y_n). Required to set the coordinate data (X_0 , Y_0) from the 0th point. The input value should be larger than the previous coordinate data ($X_n < X_{n+1}$).	Input value: 0 to 2147483647 [Cam axis cycle units] Output value: -2147483648 to 2147483647 [Output axis position units]	0	[Cd.607] Cam data value

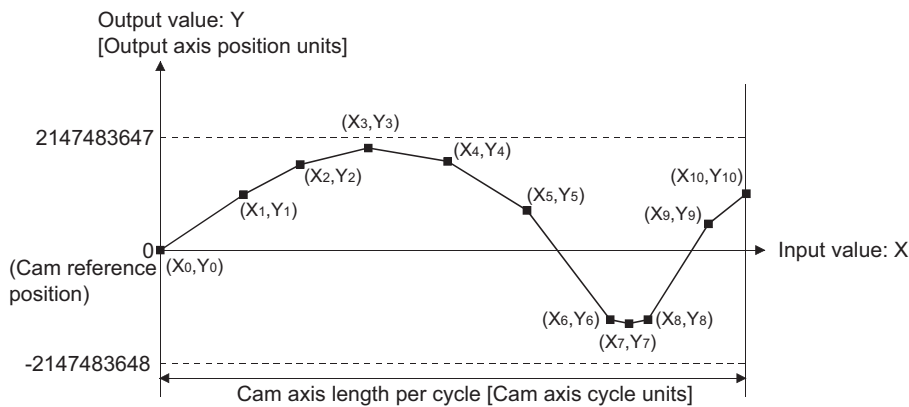

When an input value that is 0 or the cam axis length per cycle does not exist in the coordinate data, the coordinate is calculated from the line segment between the nearest two coordinates.

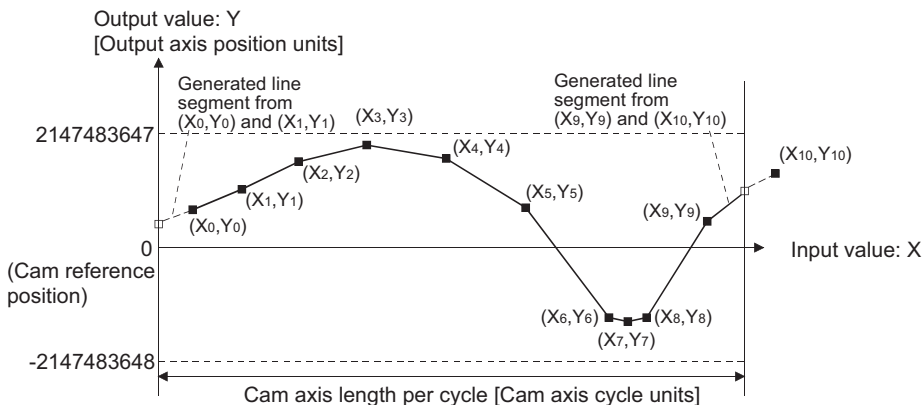

■Auto-generation data format

A cam pattern is created based on the specified parameter (data for auto-generation). Control cam data is created in the stroke ratio data format in the cam open area. Therefore, the operation specification during the control conforms to the cam operation in the stroke ratio data format.

The types of cam patterns for auto-generation data format are as follows.

Auto-generation type	Features
Cam for rotary cutter [RD77MS]	The cam pattern for a rotary cutter can be created easily.
Cam for rotary cutter (central reference) [RD77GF]	The cam pattern for a rotary cutter can be created easily. An adjustment based on the center of the sheet is carried out easily.
Easy stroke ratio cam [RD77GF]	Create the cam data such as the stroke ratio cam data created with the engineering tool. Sections, stroke amounts and cam curve types can be specified.
Advanced stroke ratio cam [RD77GF]	Create the cam data equal to the stroke ratio cam data created with the engineering tool. Sections, stroke amounts, cam curve types and cam curve detailed parameters can be specified.

⚠ CAUTION

- If the cam data is set incorrectly, similarly to the incorrect setting of a target value and command speed in the positioning control, the position and speed command to the servo amplifier increases, and may cause machine interface and servo alarms such as "Overspeed" and "Command frequency error". When creating and changing cam data, execute a trial operation and provide the appropriate adjustments. Refer to the following for precautions on test operations and adjustments. (Page 1 SAFETY PRECAUTIONS)

Feed current value of cam axis

The feed current value is calculated as shown below.

■Stroke ratio data format

Feed current value = Cam reference position + (Cam stroke amount × Stroke ratio corresponding to cam axis current value per cycle)

■Coordinate data format

Feed current value = Cam reference position + Output value corresponding to cam axis current value per cycle

When the cam axis current value per cycle is in the middle of the defined cam data (Stroke ratio data/Coordinate data), the middle value is calculated from the nearest cam data.

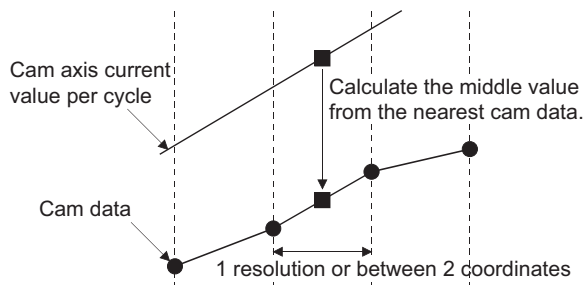

Cam reference position

The cam reference position is calculated as shown below.

■Stroke ratio data format

Cam reference position = The preceding cam reference position + (Cam stroke amount × Stroke ratio at the last point)

■Coordinate data format

Cam reference position = The preceding cam reference position + Output value corresponding to "Input value = Cam axis length per cycle" - Output value corresponding to "Input value = 0"

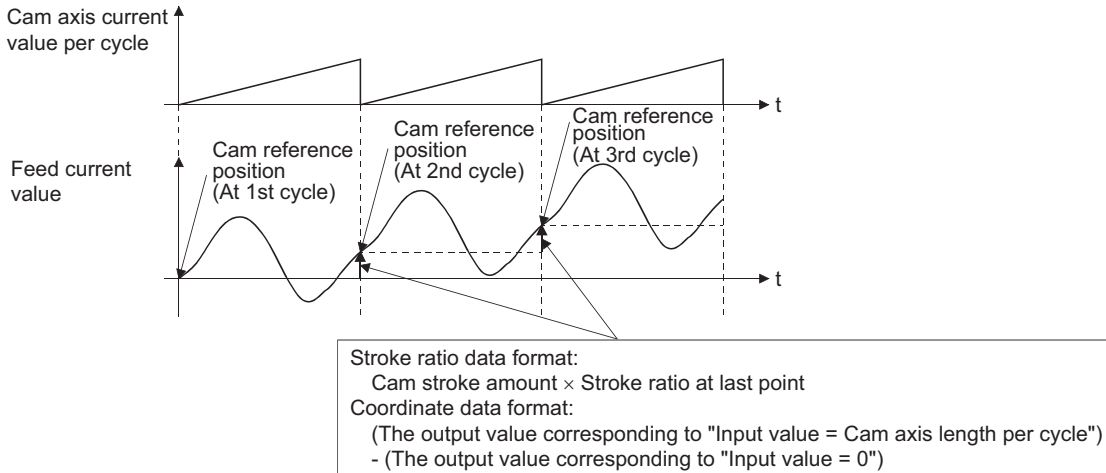

Create cam data for two-way cam operation as shown below.

■Stroke ratio data format

Create cam data so that the stroke ratio is 0% at the last point.

■Coordinate data format

Create cam data with the same output value for the point where the input value is 0 and the input value is equal to the cam axis length per cycle.

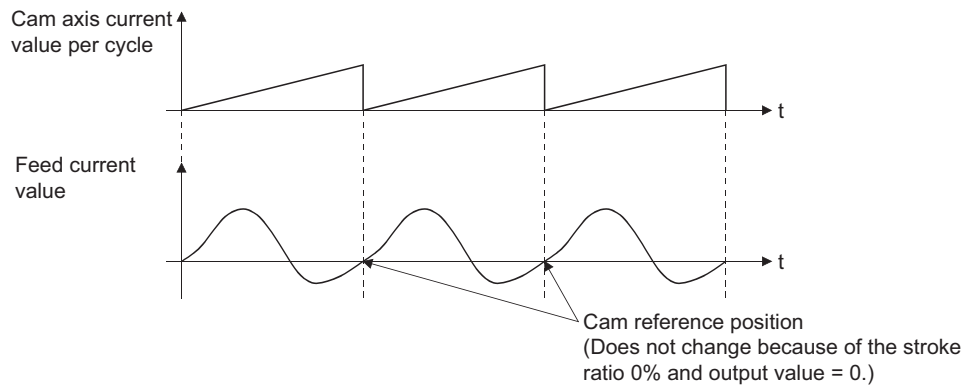

Cam data starting point

This setting is only valid for cam data using the stroke ratio data format.

The cam data point corresponding to "Cam axis current value per cycle = 0" can be set as the cam data starting point.

The default value of the cam data starting point is 0. (The cam axis is controlled with cam data starting from the 0th point (stroke ratio 0%).)

When a value other than 0 is set for the cam data starting point, cam control is started from the point where the stroke ratio is not 0%.

The cam data starting point is set for each cam data. The setting range is from 0 to (cam resolution - 1).

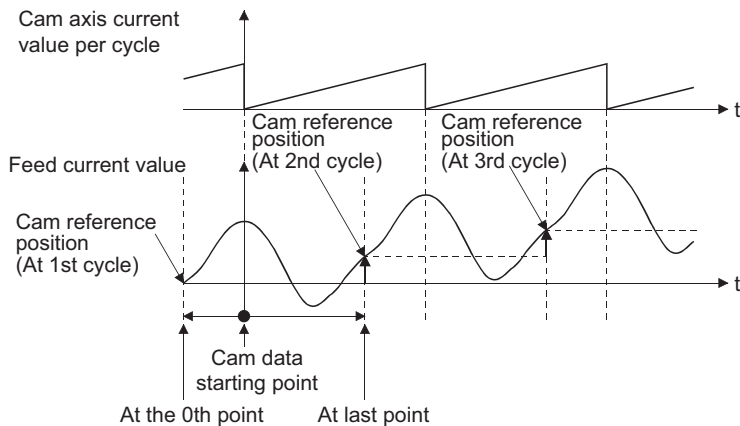

Timing of applying cam control data

■Stroke ratio data format

If "[Pr.439] Cam axis length per cycle", "[Pr.440] Cam No." or "[Pr.441] Cam stroke amount" is changed during synchronous control, the new value is accepted and applied when the cam axis current value per cycle passes through the 0th point of cam data, or is on the 0th point.

The cam reference position is updated when the cam axis current value per cycle passes through the 0th point of cam data.

■Coordinate data format

If "[Pr.439] Cam axis length per cycle" or "[Pr.440] Cam No." is changed during synchronous control, the new value is accepted and applied when the cam axis current value per cycle passes through 0, or is on 0.

The cam reference position is updated when the cam axis current value per cycle passes through 0.

3.2 Create Cam Data

Memory configuration of cam data

Cam data is arranged in the following 2 areas.

Memory configuration	Storage item	Details	Remark
Cam storage area	Cam data	Data is written by the following operations. <ul style="list-style-type: none"> • Write with the engineering tool • When executing "write (Cam storage area)" with the cam data operation function. 	<ul style="list-style-type: none"> • Data is preserved even when turning the power supply OFF. [RD77MS] • When the module extended parameter storage location is set to "Simple Motion module": Data is preserved even when turning the power supply OFF. [RD77GF] • When the module extended parameter storage location is set to "CPU module": Data written in the cam storage area is lost when turning the power supply OFF. [RD77GF]
	Cam auto-generation data	Data is written when the cam auto-generation request is executed. (Cam auto-generation function)	
Cam open area	Cam data	Cam data is transmitted from the cam storage area by the following operations. <ul style="list-style-type: none"> • Power supply turn ON • Write to the cam storage area • PLC READY signal [Y0] OFF to ON [RD77MS] • When specifying the cam open area with the cam data operation function • When executing the cam auto-generation function 	<ul style="list-style-type: none"> • Data is lost when turning the power supply OFF. • The cam data that is used in cam control is stored.

- RD77MS

Previously written cam data can be used after turning the power supply OFF by writing data in the cam storage area. Cam data should be written in the cam storage area for normal use.

- RD77GF

When the module extended parameter storage location is set to "Simple Motion module", previously written cam data can be used after turning the power supply OFF by writing data in the cam storage area.

When the module extended parameter storage location is set to "CPU module", data written in the cam storage area with the cam data operation function and the cam auto-generation function is lost by turning the power supply OFF. Refer to the following for details.

 MELSEC iQ-R Simple Motion Module User's Manual (Application)

Point

[RD77GF]

When the module extended parameter storage location is set to "Simple Motion module", there is the upper limit of writing numbers to the cam storage area (flash ROM). If the writing numbers to the flash ROM exceed the upper limit, the writing to the flash ROM may be disabled and the error "Flash ROM write error" (error code: 1931H) will occur.

It is recommended that data which is not necessary to be held at the power supply OFF is not written in the cam storage area with the cam data operation function and the cam auto-generation function.

It is possible to write directly to the cam open area via buffer memory when registering cam data that exceeds the memory capacity in the cam storage area, etc. ( Page 74 Cam data operation function) However, writing must be executed to the cam open area every time due to clearing the data at the power supply OFF.

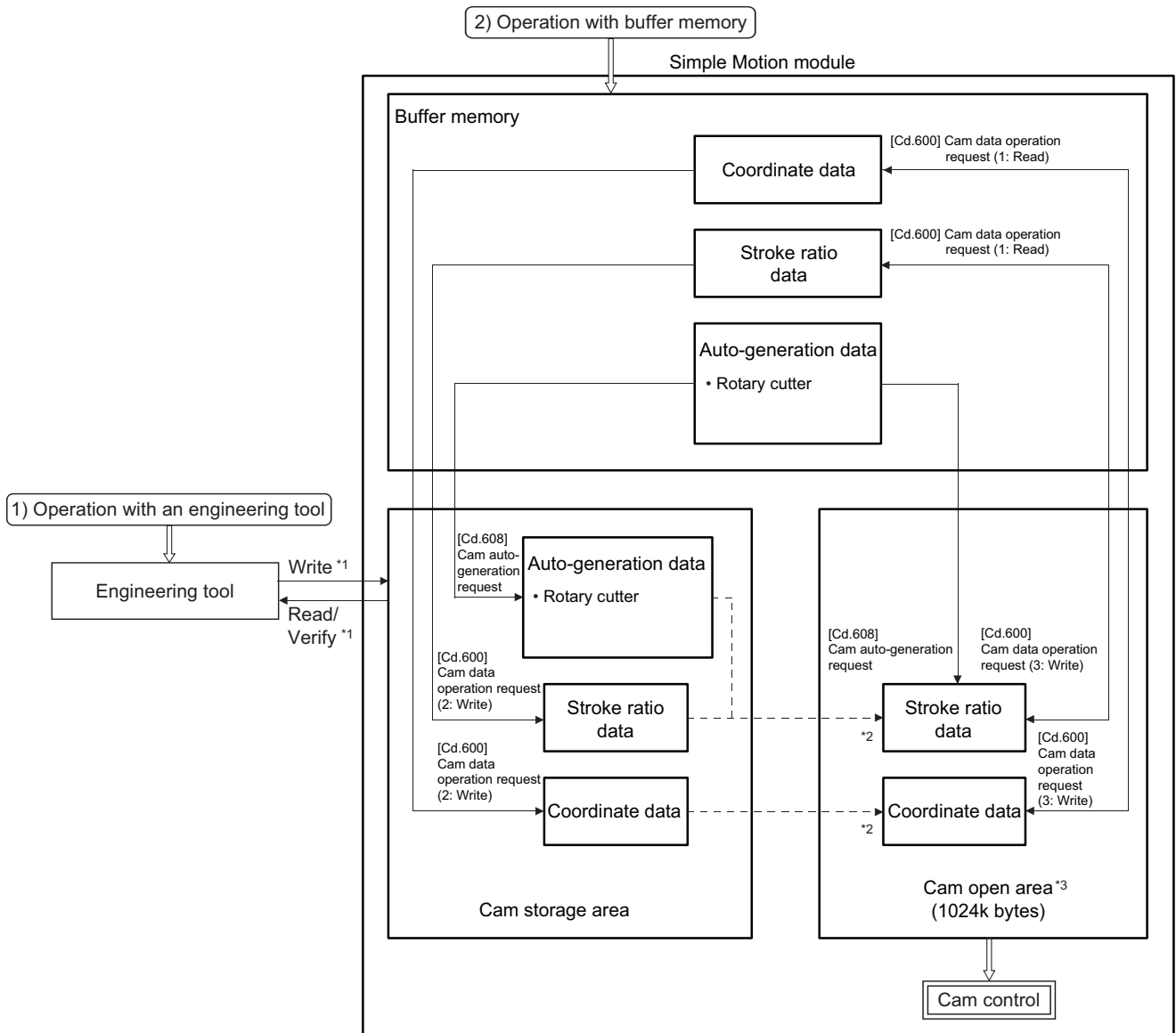

*1 The operation from the engineering tool is executed toward cam storage area.

*2 Writing to cam open area is transmitted in the following timing.

- Power supply turn ON
- Write to cam storage area
- PLC READY signal [Y0] OFF to ON

*3 Data in the cam storage area is cleared when the power supply is turned ON again or reset.

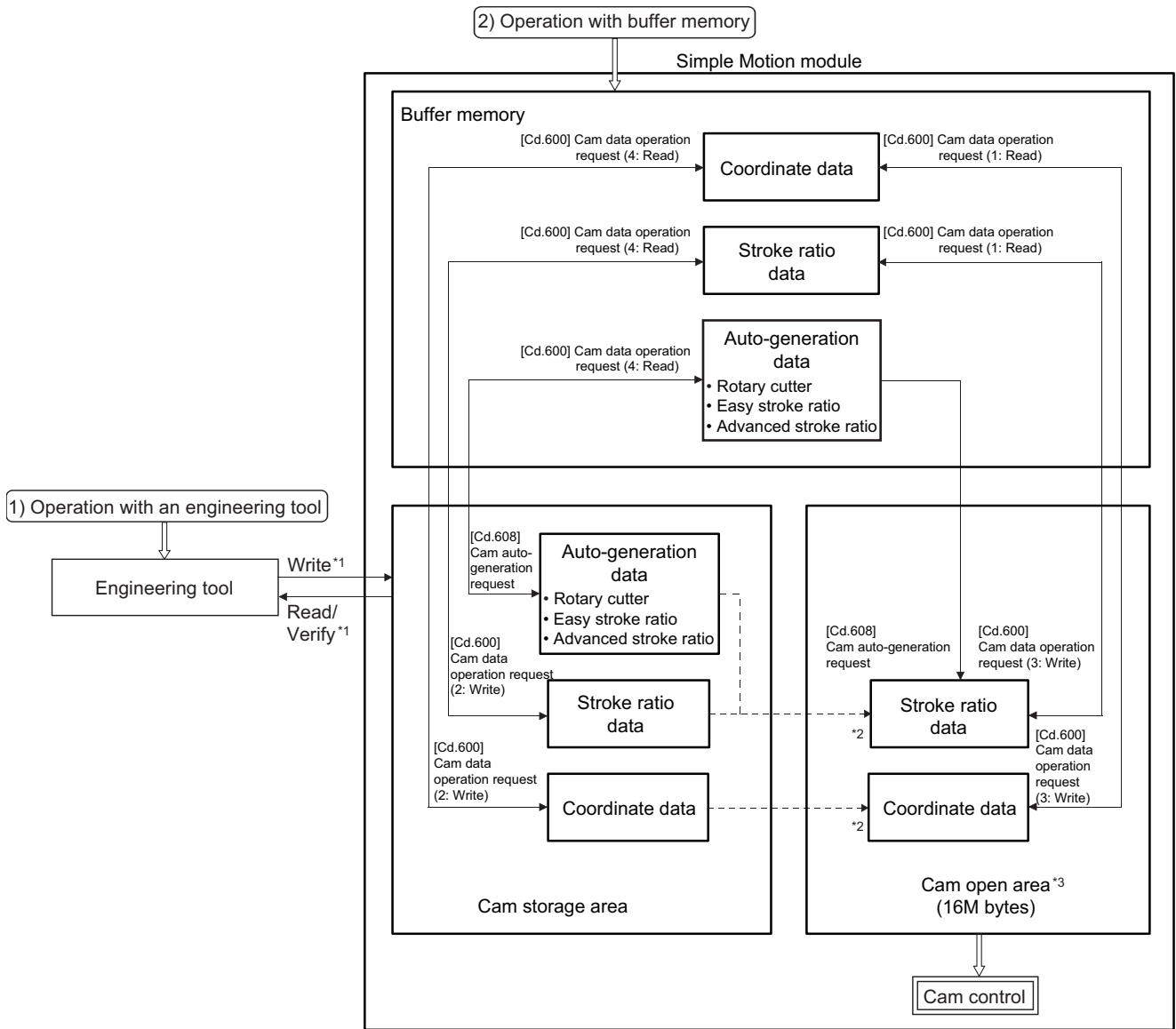

*1 The operation from the engineering tool is executed toward cam storage area.
 *2 Writing to cam open area is transmitted in the following timing.
 - Power supply turn ON
 - When "5: Transfer" is set in "[Cd.600] Cam data operation request"
 *3 Data in the cam storage area is cleared when the power supply is turned ON again or reset.

Cam data operation with an engineering tool

Cam data can be modified while viewing the waveform with the engineering tool.

The cam data is written/read/verified to the cam storage area with the engineering tool, however it cannot be executed to the cam open area.

The waveform generated by the cam auto-generation function can be confirmed by the "Cam graph" of the "Cam Data window" from the Navigation window ⇒ "Cam Data" through reading with the engineering tool.

Cam data operation with buffer memory

It is possible to specify the area where cam data is written. The cam data is read from the cam open area. (☞ Page 74 Cam data operation function)

With the cam auto-generation function, auto-generation data is saved in the cam storage area, and the cam data is generated into the cam open area.

Cam data capacity

- RD77MS

The size of the created cam data is shown below for the cam storage area/cam open area.

Operation method	Data method/Auto-generation type	Cam storage area (262144 bytes)	Cam open area (1048576 bytes)
Create with an engineering tool	Stroke ratio data format	Cam resolution × 4 bytes	Cam resolution × 4 bytes
	Coordinate data format	Coordinate number × 8 bytes	Coordinate number × 8 bytes
Create in cam storage area with cam data operation function	Stroke ratio data format	Cam resolution × 4 bytes	Cam resolution × 4 bytes
	Coordinate data format	Coordinate number × 8 bytes	Coordinate number × 8 bytes
Create in cam open area with cam data operation function	Stroke ratio data format	0 byte	Cam resolution × 4 bytes
	Coordinate data format		Coordinate number × 8 bytes
Create with cam auto-generation	For a rotary cutter	28 bytes	Cam resolution × 4 bytes

When writing with the cam data operation function or when the cam auto-generation function is executed, the writing area free capacity size may decrease since the size changes depending on the cam resolution change, etc. In this case, write the cam data with the engineering tool or delete them once.

- RD77GF

The size of the created cam data is shown below for the cam open area.

Operation method	Data method/Auto-generation type		Cam open area (16M bytes)
Create with an engineering tool	Auto-generation data format		Cam resolution × 4 bytes
	Coordinate data format		Coordinate number × 8 bytes
Create with cam data operation function	Stroke ratio data format		Cam resolution × 4 bytes
	Coordinate data format		Coordinate number × 8 bytes
Create with cam auto-generation	Auto-generation data format	Cam for rotary cutter (central reference)	Cam resolution × 4 bytes
		Easy stroke ratio cam	
		Advanced stroke ratio cam	

Delete method of cam data

The data of cam storage area/cam open area can be deleted (initialize) by the parameter initialization function with a parameter setting and positioning data. The parameter initialization function is executed by setting "1" in "[Cd.2] Parameter initialization request".

Write the empty data in the cam storage area with the engineering tool to delete only cam data.

Password protection for cam data

The cam data can be protected as shown below by password setting.

Password setting	Cam data operation with an engineering tool	Cam data operation with buffer memory
Password for read protection	Cam data cannot be read without unlocking the password for read protection.	Reading cam data is not operated.
Password for write protection	Cam data cannot be written without unlocking the password for write protection.	Writing cam data and generating cam data auto-generation is not operated.

Point

[RD77GF]

The password is set as follows.

- When the module extended parameter storage location is set to "Simple Motion module":
Set using the Simple Motion module setting function of the engineering tool.
- When the module extended parameter storage location is set to "CPU module":
Set using the file password of the module extended parameters (For the cam data operation with buffer memory, it is based on the file password status of the module extended parameters.)

The password for cam data is deleted with cam data by "[Cd.2] Parameter initialization request". (When the module extended parameter storage location is set to "Simple Motion module" [RD77GF])

Cam data operation function

This function is used to write/read cam data via buffer memory with the cam operation control data. To operate the points more than the amount of data for each operation (as follows), the operation should be executed separately.

Cam data format	Amount of data for each operation
Stroke ratio data format	4096 [RD77MS] 32768 [RD77GF]
Coordinate data format	2048 [RD77MS] 65535 [RD77GF]

Cam operation control data

Setting item	Setting details	Setting value (Read operation: Stored value)	Default value	Buffer memory address
[Cd.600] Cam data operation request	<ul style="list-style-type: none"> Set the command for operating cam data. The Simple Motion module resets the value to "0" automatically after completion of cam data operation. Fetch cycle: <u>Main cycle</u> ^{*1}	■Set in decimal. 1: Read (Cam open area) 2: Write (Cam storage area) 3: Write (Cam open area) 4: Read (Cam storage area) [RD77GF] 5: Transfer [RD77GF] -1: Zero clear [RD77GF]	0	45000 [RD77MS] 600000 [RD77GF]
[Cd.601] Operation cam No.	<ul style="list-style-type: none"> Set the operating cam No. Fetch cycle: <u>At requesting cam data operation</u>	■Set in decimal. 1 to 256 [RD77MS] 0: All cams (At transfer request only) [RD77GF] 1 to 1024 [RD77GF]	0	45001 [RD77MS] 600001 [RD77GF]
[Cd.602] Cam data first position	<ul style="list-style-type: none"> Set the first position for the operating cam data. Fetch cycle: <u>At requesting cam data operation</u>	■Set in decimal. <ul style="list-style-type: none"> Stroke ratio data format: 1 to cam resolution Coordinate data format: 0 to (coordinate number - 1) 	0	45002 [RD77MS] 600002 [RD77GF]
[Cd.603] Number of cam data operation points	<ul style="list-style-type: none"> Set the number of operating cam data points. Fetch cycle: <u>At requesting cam data operation</u>	■Set in decimal. [RD77MS] <ul style="list-style-type: none"> Stroke ratio data format: 1 to 4096 Coordinate data format: 1 to 2048 [RD77GF] Stroke ratio data format: 1 to 32768 Coordinate data format: 1 to 65535 	0	45003 [RD77MS] 600003 [RD77GF]
[Cd.604] Cam data format	<ul style="list-style-type: none"> Write operation: Set cam data format. Read operation: The cam data format is stored. Fetch cycle: <u>At requesting cam data operation</u> Refresh cycle: <u>At completing cam data operation</u>	■Set in decimal. 1: Stroke ratio data format 2: Coordinate data format 102: Cam auto-generation data format for rotary cutter cam (Central reference) [RD77GF] 103: Cam auto-generation data format for easy stroke ratio cam [RD77GF] 104: Cam auto-generation data format for advanced stroke ratio cam [RD77GF]	0	45004 [RD77MS] 600004 [RD77GF]
[Cd.605] Cam resolution/coordinate number	<ul style="list-style-type: none"> Write operation: Set the cam resolution/the coordinate number. Read operation: The cam resolution/the coordinate number is stored. Fetch cycle: <u>At requesting cam data operation</u> Refresh cycle: <u>At completing cam data operation</u>	■Set in decimal. <ul style="list-style-type: none"> Stroke ratio data format: 256/512/1024/2048/4096/8192/16384/32768 Coordinate data format: 2 to 16384 [RD77MS], 2 to 65535 [RD77GF] 	0	45005 [RD77MS] 600005 [RD77GF]
[Cd.606] Cam data starting point	<ul style="list-style-type: none"> Write operation: Set the cam data starting point. Read operation: The cam data starting point is stored. Fetch cycle: <u>At requesting cam data operation</u> Refresh cycle: <u>At completing cam data operation</u> • Setting is not required with coordinate data format.	■Set in decimal. <ul style="list-style-type: none"> Stroke ratio data format: 0 to (Cam resolution - 1) Coordinate data format: Setting not required 	0	45006 [RD77MS] 600006 [RD77GF]

Setting item	Setting details	Setting value (Read operation: Stored value)	Default value	Buffer memory address
[Cd.607] Cam data value	<ul style="list-style-type: none"> Write operation: Set the cam data corresponding to the cam data format. <u>Fetch cycle: At requesting cam data operation</u> <ul style="list-style-type: none"> Read operation: The cam data is stored. <u>Refresh cycle: At completing cam data operation</u>	<ul style="list-style-type: none"> Set in decimal. Stroke ratio data format -2147483648 to 2147483647 [$\times 10^{-7}\%$] Coordinate data format Input value: 0 to 2147483647 [Cam axis cycle units^{*2}] Output value: -2147483648 to 2147483647 [Output axis position units^{*3}] 	0	45008 to 53199 [RD77MS] 600008 to 862147 [RD77GF]

*1 With the exception of positioning control, main cycle processing is executed during the next available time. It changes by status of axis start.

*2 Cam axis cycle units ( Page 126 Units for the output axis)

*3 Output axis position units ( Page 126 Units for the output axis)

[Cd.600] Cam data operation request

Set the following commands to write/read cam data.

Setting value	Details
1: Read (Cam open area)	The cam data is read from the cam open area and stored to the buffer memory.
2: Write (Cam storage area)	The cam data is written to the cam storage area and the cam open area from the buffer memory.
3: Write (Cam open area)	The cam data is written to the cam open area from the buffer memory.
4: Read (Cam storage area) [RD77GF]	The data is read from the cam storage area and stored to the buffer memory.
5: Transfer [RD77GF]	The data is written to the cam open area from the cam storage area.
-1: Zero clear [RD77GF]	All the buffer memories of "[Cd.607] Cam data value" are cleared to 0.

The setting value is reset to "0" automatically after completion of cam data operation.

If a warning occurs when requesting cam data operation, the warning No. is stored in "[Md.24] Axis warning No." of axis 1, and the setting value is reset to "0" automatically.

When another request command is set, the operation does not get executed and the setting value is reset to "0" automatically.

[Cd.601] Operation cam No.

Set the cam No. to write/read.

[Cd.602] Cam data first position

Set the first position of the cam data to write/read.

Set the cam data first position within the range from 1 to the cam resolution in cam resolution units using the stroke ratio data format. The stroke ratio of the 0th cam data is 0% fixed, and this data cannot be written/read.

Set a value within the range from 0 to (Coordinate number - 1) with the coordinate data format.

[Cd.603] Number of cam data operation points

Set the number of operation points to write/read starting from the first position of cam data.

- Stroke ratio data format

The following shows the operation details when the value of "Cam data first position + Cam data operation points - 1" is larger than the cam resolution in the stroke ratio data format.

Operation	Details
Reading	The cam data from the first position to the cam resolution is read in the buffer memory.
Writing	The warning "Outside number of cam data operation points range" (warning code: 0C43H) occurs, and writing is not executed.

- Coordinate data format

The following shows the operation details when the value of "Cam data first position + Cam data operation points" is larger than the coordinate number with the coordinate data format.

Operation	Details
Reading	The cam data from the first position to the last coordinate is read in the buffer memory.
Writing	The warning "Outside number of cam data operation points range" (warning code: 0C43H) occurs, and writing is not executed.

[Cd.604] Cam data format

Set one of the following cam data formats.

- RD77MS

Setting value	Details
1	Stroke ratio data format
2	Coordinate data format

- RD77GF

Setting value	Details
Reading (Cam open area)	1: Stroke ratio data format 2: Coordinate data format
Reading (Cam storage area)	1: Stroke ratio data format 2: Coordinate data format 102: Cam auto-generation data format for rotary cutter cam (Central reference) 103: Cam auto-generation data format for easy stroke ratio cam 104: Cam auto-generation data format for advanced stroke ratio cam
Writing	1: Stroke ratio data format 2: Coordinate data format

[Cd.605] Cam resolution/coordinate number

Set/load the cam resolution/the coordinate number.

Operation	Details
Reading	The cam resolution/the coordinate number of the set cam data is read.
Writing	Set the cam resolution with the following values when using the stroke ratio data format. 256/512/1024/2048/4096/8192/16384/32768 Set the coordinate number within the following range when using the coordinate data format. 2 to 16384 [RD77MS], 2 to 65535 [RD77GF]

[Cd.606] Cam data starting point

Set/load the cam data starting point. This is used with the stroke ratio data format.

Operation	Details
Reading	The cam starting point of the set cam data is read.
Writing	Set the cam data starting point within the range from 0 to (Cam resolution - 1).

[Cd.607] Cam data value

Set/load the cam data operation points according to one of the following formats.

■Stroke ratio data format

• RD77MS

Buffer memory address	Item	Setting value
45008 45009	Stroke ratio at first point	-2147483648 to 2147483647 [$\times 10^{-7}\%$] (-214.7483648 to 214.7483647 [%])
45010 45011	Stroke ratio at second point	
⋮	⋮	
53198 53199	Stroke ratio at 4096th point	

• RD77GF

Buffer memory address	Item	Setting value
600008 600009	Stroke ratio at first point	-2147483648 to 2147483647 [$\times 10^{-7}\%$] (-214.7483648 to 214.7483647 [%])
600010 600011	Stroke ratio at second point	
⋮	⋮	
862146 862147	Stroke ratio at 32768th point	

■Coordinate data format

• RD77MS

Buffer memory address	Item		Setting value
45008 45009	At first point	Input value	0 to 2147483647 [Cam axis cycle unit]
45010 45011		Output value	-2147483648 to 2147483647 [Output axis position unit]
45012 45013	At second point	Input value	0 to 2147483647 [Cam axis cycle unit]
45014 45015		Output value	-2147483648 to 2147483647 [Output axis position unit]
⋮	⋮	⋮	⋮
53196 53197	At 2048th point	Input value	0 to 2147483647 [Cam axis cycle unit]
53198 53199		Output value	-2147483648 to 2147483647 [Output axis position unit]

• RD77GF

Buffer memory address	Item		Setting value
600008 600009	At first point	Input value	0 to 2147483647 [Cam axis cycle unit]
600010 600011		Output value	-2147483648 to 2147483647 [Output axis position unit]
600012 600013	At second point	Input value	0 to 2147483647 [Cam axis cycle unit]
600014 600015		Output value	-2147483648 to 2147483647 [Output axis position unit]
⋮	⋮	⋮	⋮
862144 862145	At 65535th point	Input value	0 to 2147483647 [Cam axis cycle unit]
862146 862147		Output value	-2147483648 to 2147483647 [Output axis position unit]

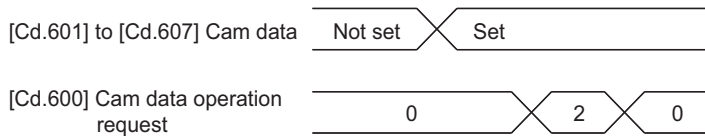

■Auto-generation data format [RD77GF]

When the reading (cam storage area) is executed to the cam data created with the cam auto-generation or the cam data created with the cam curve by the engineering tool, the data is read as auto-generation data format.

- Cam for rotary cutter (central reference) data
- Easy stroke ratio cam data
- Advanced stroke ratio cam data

For the buffer memory assignment at reading, refer to the following.

☞ Page 81 [Cd.611] Cam auto-generation data

However, cam data created by a free-form curve cannot be read.

Cam auto-generation function

The cam auto-generation function is used to generate cam data automatically for specific purposes based on parameter settings.

With this function, cam data is generated in the cam open area.

It is possible to generate up to 1 Mbyte [RD77MS] or 16 Mbyte [RD77GF] including the regular cam data. (Example: 256 cam data (with the stroke ratio format, resolution is 1024) [RD77MS] or 1024 cam data (with the stroke ratio format, resolution is 4096) [RD77GF] can be automatically generated.)

The processing time of cam auto-generation takes longer if the data point is larger. Also, the real processing time changes by status of axis start etc.

(Reference) Relationship between the cam resolution and processing time in the cam auto-generation (Stroke ratio data format)

[RD77MS]

Operation cycle	Maximum number of control axes	256	4096	32768
0.444	For 2 axes	825 [μ s]	10248 [μ s]	75898 [μ s]
0.888	For 4 axes	746 [μ s]	8929 [μ s]	65950 [μ s]
1.777	For 16 axes	1379 [μ s]	12533 [μ s]	95997 [μ s]

[RD77GF]

Operation cycle	Maximum number of control axes	256	4096	32768
0.50	For 2 axes	40548 [μ s]	51841 [μ s]	137464 [μ s]
1.00	For 4 axes	38895 [μ s]	47308 [μ s]	113119 [μ s]
2.00	For 16 axes	40958 [μ s]	47471 [μ s]	105217 [μ s]
4.00	For 32 axes	42533 [μ s]	51289 [μ s]	107538 [μ s]

Cam operation control data

Setting item	Setting details	Setting value	Default value	Buffer memory address
[Cd.608] Cam auto-generation request	<ul style="list-style-type: none"> Set the request for cam auto-generation. The Simple Motion module resets the value to "0" automatically after completion of the cam auto-generation. Fetch cycle: Main cycle* ¹	■Set in decimal. 1: Cam auto-generation request 2: Cam auto-generation request (without writing to storage area) [RD77GF]	0	53200 [RD77MS] 862200 [RD77GF]
[Cd.609] Cam auto-generation cam No.	<ul style="list-style-type: none"> Set the cam No. to be generated automatically. Fetch cycle: At requesting cam auto-generation	■Set in decimal. 1 to 256 [RD77MS] 1 to 1024 [RD77GF]	0	53201 [RD77MS] 862201 [RD77GF]
[Cd.610] Cam auto-generation type	<ul style="list-style-type: none"> Set the type of cam auto-generation. Fetch cycle: At requesting cam auto-generation	■Set in decimal. 1: Cam for rotary cutter [RD77MS] 2: Cam for rotary cutter (central reference) [RD77GF] 3: Easy stroke ratio cam [RD77GF] 4: Advanced stroke ratio cam [RD77GF]	0	53202 [RD77MS] 862202 [RD77GF]
[Cd.611] Cam auto-generation data	<ul style="list-style-type: none"> Set the parameters for each type of cam auto-generation. Fetch cycle: At requesting cam auto-generation	( Page 81 [Cd.611] Cam auto-generation data)	0	53204 to 53779 [RD77MS] 862204 to 866295 [RD77GF]

*1 With the exception of positioning control, main cycle processing is executed during the next available time. It changes by status of axis start.

[Cd.608] Cam auto-generation request

Set "1: Cam auto-generation request" or "2: Cam auto-generation request (without writing to storage area)" [RD77GF] to execute cam auto-generation.

Cam data is generated in the cam open area of the specified cam No. based on the cam auto-generation data.

The setting value is reset to "0" automatically after completing the process.

The cam auto-generation data is saved in the cam storage area. The cam auto-generation is executed automatically again when the next power supply turns ON or PLC READY signal [Y0] OFF to ON. [RD77MS]

When "1: Cam auto-generation request" is set and the module extended parameter storage location is set to "Simple Motion module", the cam auto-generation data is saved in the cam storage area (flash ROM). The cam auto-generation is executed automatically again when the next power supply turns ON or "5: Transfer" is set in "[Cd.600] Cam data operation request". [RD77GF]

If a warning occurs when requesting cam auto-generation, the warning No. is stored in "[Md.24] Axis warning No." of axis 1, and the setting value is reset to "0" automatically.

When another request command is set, this function does not get executed and the setting value is reset to "0" automatically.

[Cd.609] Cam auto-generation cam No.

Set the cam No. to be generated automatically.

[Cd.610] Cam auto-generation type

Set the type of cam auto-generation.

[Cd.611] Cam auto-generation data

Set the cam auto-generation data corresponding to "[Cd.610] Cam auto-generation type".

■Cam auto-generation data for rotary cutter [RD77MS]

The cam data starting point for a rotary cutter is 0.

Buffer memory address	Item	Setting value	Details
53204	Cam resolution	256/512/1024/2048/4096/8192/16384/32768	Set the cam resolution for generating the cam.
53206 53207	Sheet length	1 to 2147483647 [[Optional] Same unit (0.1 mm, etc.)]	Set the sheet length. Set this value in the cam axis length per cycle.
53208 53209	Sheet synchronization width	1 to 2147483647 [[Optional] Same unit (0.1 mm, etc.)]	Set the sheet length of the synchronous section.
53210 53211	Synchronous axis length	1 to 2147483647 [[Optional] Same unit (0.1 mm, etc.)]	Set the cycle length of the rotary cutter shaft.
53212 53213	Synchronization starting point	0 to 2147483647 [[Optional] Same unit (0.1 mm, etc.)]	Set the length from the beginning of the sheet to the start of the synchronous section.
53214	Synchronous section acceleration ratio	-5000 to 5000 [0.01%]	Set when the synchronous speed in the synchronous section needs to be adjusted. The speed is "Synchronous speed × (100% + Acceleration ratio)" in the synchronous section.

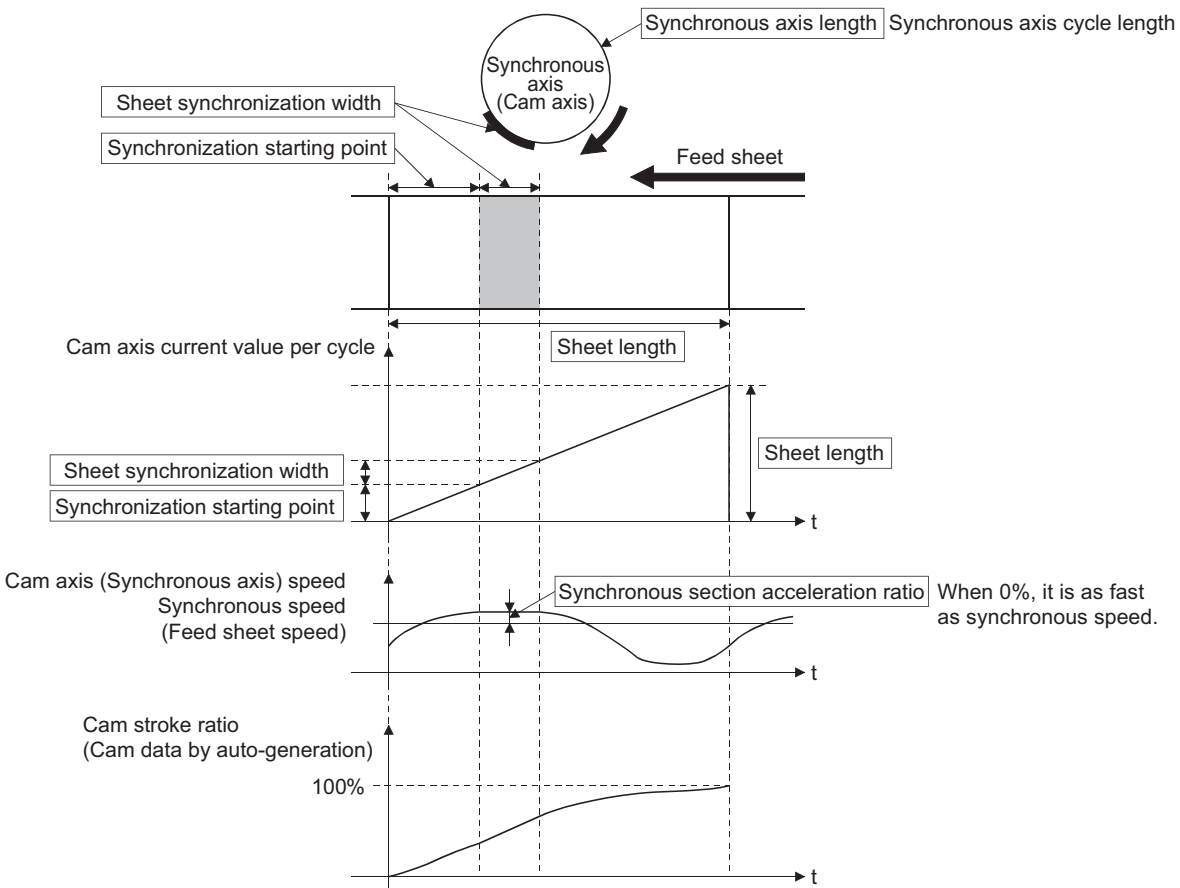

■Cam auto-generation data for rotary cutter (central reference) [RD77GF]

When the synchronous position adjustment is set to 0, the cam pattern of which the sheet center is in the synchronous section is created.

Buffer memory address	Item	Setting value	Details
862204 862205	Cam resolution	256/512/1024/2048/4096/8192/16384/32768	Set the cam resolution for generating the cam.
862206	Auto-generation option	<ul style="list-style-type: none"> • Bit 0: Acceleration/deceleration system 0: Trapezoidal acceleration/deceleration 1: S-curve acceleration/deceleration • Bit1: Synchronous axis length setting 0: Diameter 1: Cycle length 	<ul style="list-style-type: none"> • Select the trapezoidal acceleration/deceleration system or the S-curve acceleration/deceleration system with bit 0. • Select the diameter or the cycle length for the synchronous axis length setting with bit 1. • Set "0" for bit 2 to 15.
862207	Synchronous section acceleration ratio	-5000 to 5000 [0.01%]	Set when the synchronous speed in the synchronous section needs to be adjusted. The speed is "Synchronous speed × (100% + Acceleration ratio)" in the synchronous section.
862208 862209	Sheet length	1 to 2147483647 [(Optional) Same units]	Set the sheet length.
862210 862211	Sheet synchronization width	1 to 2147483647 [(Optional) Same units]	<ul style="list-style-type: none"> • Set the sheet synchronization width (seal width). • When the synchronous speed section for retracting operation is required in front of and behind the sheet synchronization width, add the retracting width.
862212 862213	Synchronous axis length	For diameter setting 1 to 680000000 For cycle length setting 1 to 2147483647 [(Optional) Same units]	<ul style="list-style-type: none"> • Set the rotary cutter axis length. • When the auto-generation option is set to the diameter, it is calculated as "Cycle length = setting value × π". • When the auto-generation option is set to the cycle length, it is calculated as "Cycle length = setting value".
862214 862215	Synchronous position adjustment	-1073741823 to 1073741823 [(Optional) Same units]	<ul style="list-style-type: none"> • Set the position adjustment of the synchronous section. Negative value: The synchronous section is adjusted to the sheet start side. 0: The center of the sheet is in the synchronous section. Positive value: The synchronous section is adjusted to the sheet end side. • Set the value within one-half of the sheet length.
862216 862217	Acceleration/ deceleration width	0 to 2147483647 [(Optional) Same units] <ul style="list-style-type: none"> • For a value other than the above, the acceleration/deceleration width is calculated to be the maximum. 	<ul style="list-style-type: none"> • Set the sheet width (one side) of the acceleration/ deceleration area. • When a negative value is set, the acceleration/ deceleration width is calculated to be the maximum.
862218	Number of cutter	1 to 256	Set the number of cutter.
862219	Asynchronous speed result	0 to 65535 [0.01 times]	When the cam auto-generation is successfully performed, the asynchronous speed is stored as the ratio of the synchronous speed.

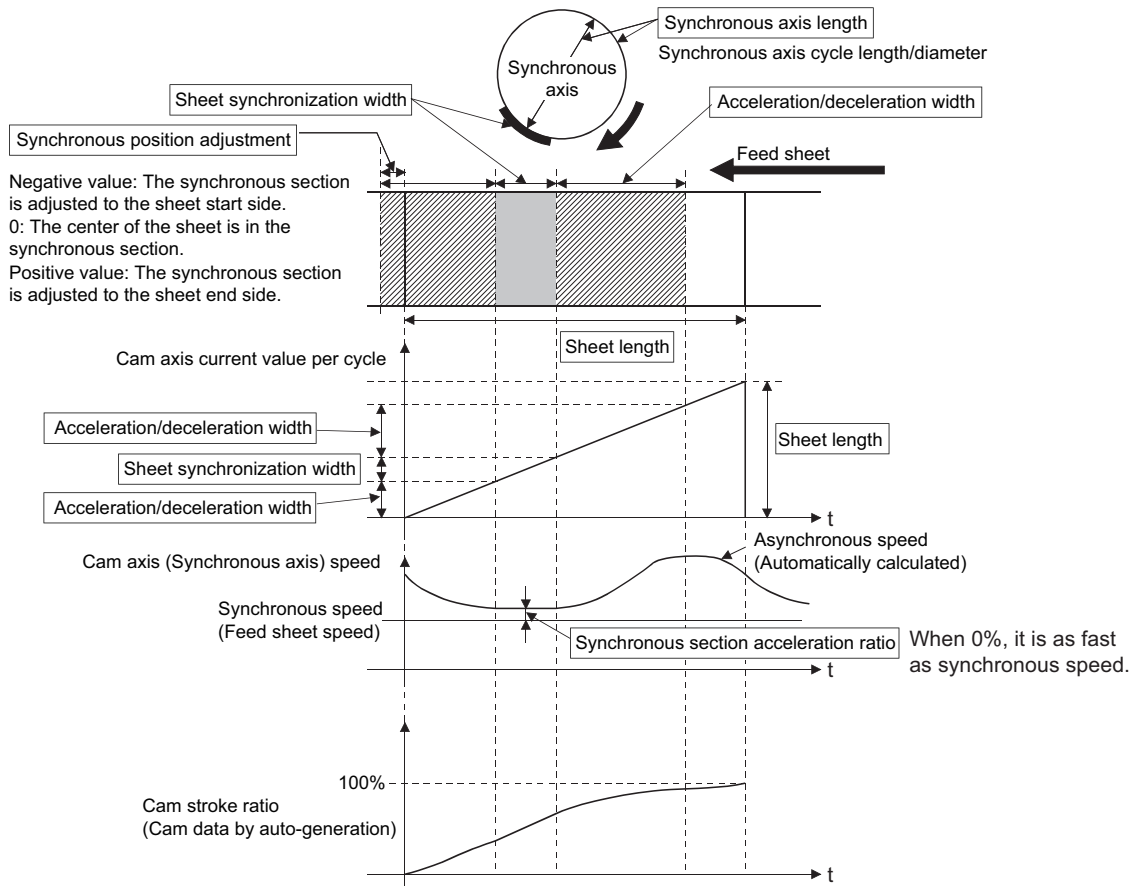

Ex.

Cam pattern created at the following settings

Acceleration/deceleration system = Trapezoidal, Synchronous axis length setting = Diameter

Synchronous section acceleration ratio = 3.00%

Sheet length = 200.0 mm

Sheet synchronization width = 30.0 mm (Seal section) + 20.0 mm (Retracting operation)

Synchronous axis length = 100.0 mm (Diameter)

Synchronous position adjustment = 20.0 mm

Acceleration/deceleration width = 55.0 mm

Number of cutter = 1

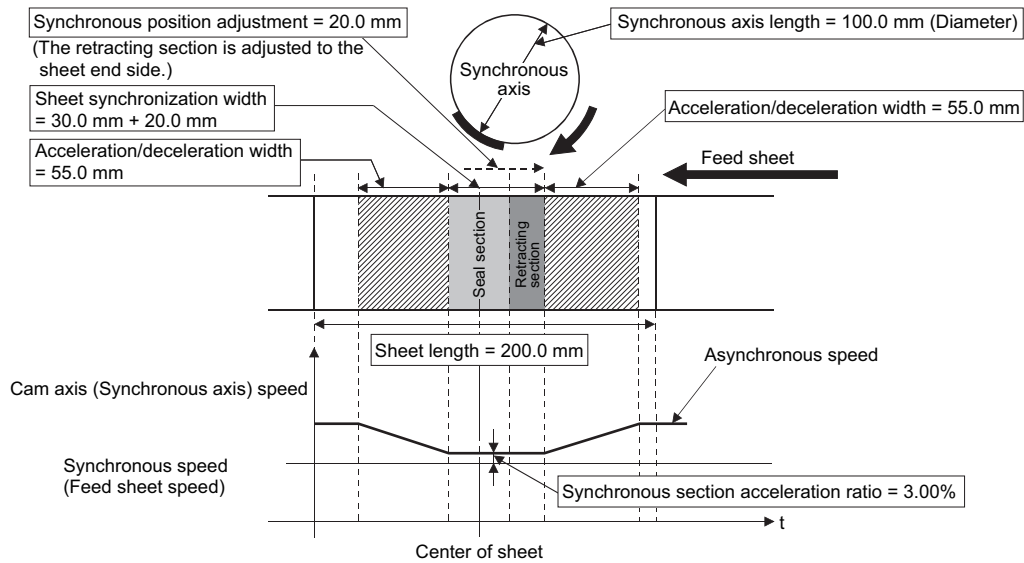

■ Easy stroke ratio cam/Advanced stroke ratio cam [RD77GF]

Cam data can be automatically generated without using the cam data setting of the engineering tool by setting the stroke amount and sections. In easy stroke ratio cam, detailed coefficients of the cam curve are omitted and the curves and number of sections that can be used are limited.

With the current value per cycle "0" as starting point, automatically generates cam data from the stroke and cam curve type of each section until the specified end point (cam axis current value per cycle).

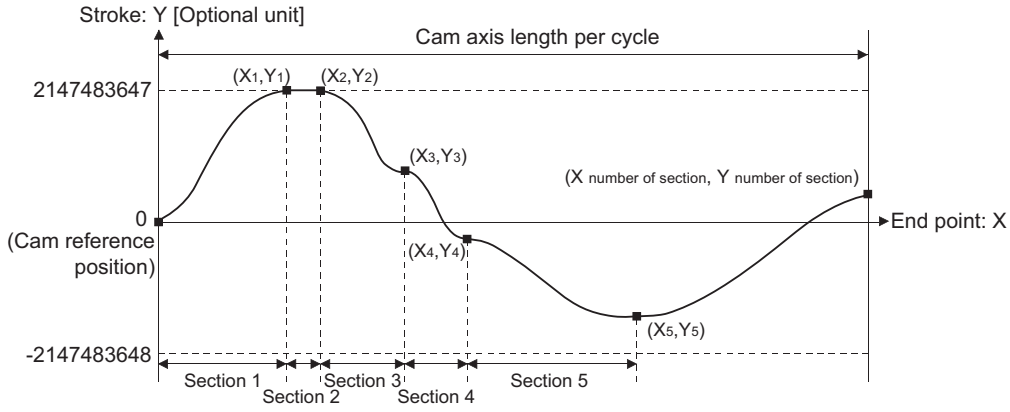

• Easy stroke ratio cam data for auto-generation

Buffer memory address	Item	Setting value	Details
862204 862205	Cam resolution	256/512/1024/2048/4096/ 8192/16384/32768	Set the cam resolution for generating the cam.
862206 862207	Cam axis length per cycle* ¹	1 to 2147483647 [Cam axis length per cycle units]	Set the required input amount with the cam per cycle.
862208 862209	Cam data starting point	0 to (Resolution - 1)	Set the starting point as the point corresponding to "cycle length = 0" of cam data.
862210	Number of sections	1 to 32	Set the number of sections of cam data. Set data for the number of sections specified.
862212	Section 1	Cam curve type* ²	0: Constant speed 1: Constant acceleration 2: Distorted trapezoid 3: Distorted sine 4: Distorted constant speed 5: Cycloid 6: 5th curve
862214 862215		End point	1 to Cam axis length per cycle [Cam axis length per cycle units] ³
862216 862217		Stroke	-2147483648 to 2147483647 [× 0.0000001%]
862218	Section 2	Cam curve type* ²	0: Constant speed 1: Constant acceleration 2: Distorted trapezoid 3: Distorted sine 4: Distorted constant speed 5: Cycloid 6: 5th curve
862220 862221		End point	1 to Cam axis length per cycle [Cam axis length per cycle units] ³
862222 862223		Stroke	-2147483648 to 2147483647 [× 0.0000001%]
⋮	⋮	⋮	
862398	Section 32	Cam curve type* ²	0: Constant speed 1: Constant acceleration 2: Distorted trapezoid 3: Distorted sine 4: Distorted constant speed 5: Cycloid 6: 5th curve
862400 862401		End point	1 to Cam axis length per cycle [Cam axis length per cycle units] ³
862402 862403		Stroke	-2147483648 to 2147483647 [× 0.0000001%]

*1 The set value is only used for cam data generation. Control is performed by the output axis parameter "[Pr.439] Cam axis length per cycle".

*2 Refer to the following for the shapes of each cam type. Use P1 = 0, P2 = 1.00, and default values for L1 and L2.

 Page 89 [Cam curve list]

*3 If setting is outside range, the cam axis length per cycle will be set as the final end point of the section settings.

• Advanced stroke ratio cam data for auto-generation

Buffer memory address	Item	Setting value	Details
862204 862205	Cam resolution	256/512/1024/2048/4096/8192/16384/ 32768	Set the cam resolution for generating the cam.
862206 862207	Cam axis length per cycle ^{*3}	1 to 2147483647 [Cam axis length per cycle units]	Set the required input amount with the cam per cycle.
862208 862209	Cam stroke amount ^{*3}	1 to 2147483647 [Cam stroke amount units]	Set the reference value for the stroke amount specified by stroke (Yn). When the cam stroke amount units are "%", this is ignored.
862210	Unit setting	<p>H</p> <p>Cam axis length per cycle units (Display) 0: mm 1: inch 2: degree 3: pulse</p> <p>Number of decimal places 0 to 9</p> <p>Cam stroke amount 0: mm 1: inch 2: degree 3: pulse 9: %</p> <p>Number of decimal places 0 to 9</p> <p>When a value outside the range is set, cam data is generated from the default value (H7952).</p>	Set the display unit of the cam axis length per cycle, and the unit for cam stroke amount in hexadecimal.
862212 862213	Cam data starting point	0 to (Resolution - 1)	Set the starting point as the point corresponding to "cycle length = 0" of cam data.
862214	Number of sections	1 to 360	Set the number of sections of cam data. Set data for the number of sections specified.
862216	Section 1 Cam curve type ^{*2}	0: Constant speed 1: Constant acceleration 2: Distorted trapezoid 3: Distorted sine 4: Distorted constant speed 5: Cycloid 6: 5th curve 7: Trapecloid 8: Reverse trapezoid 9: Double hypotenuse 10: Reverse double hypotenuse 11: Single hypotenuse	Set the cam curve.
862218 862219	End point (X1)	1 to Cam axis length per cycle [Cam axis length per cycle units] ^{*1}	Set the point for cam axis length per cycle (cam axis current value per cycle). It is necessary to set a value larger than the end point immediately before (Xn < Xn + 1). Also, for the final end point, set as the cam axis length per cycle.
862220 862221	Stroke (Y1) ^{*4}	-2147483648 to 2147483647 [Cam stroke amount units]	Set the stroke position from the cam reference position of when at the end point specified by cam axis current value per cycle.
862222	Curve applicable range (P1)	0 to 100 [× 0.01]	Set the curve applicable range (start point: P1, end point: P2) for the cam curve. Set so that "P1 < P2". When "P1 = P2 = 0", "P1 = 0" and "P2 = 100" are applied.
862223	Curve applicable range (P2)		
862224	Acceleration/deceleration range compensation (Range L1) ^{*2}	1 to 9999 [× 0.0001]	Set the acceleration/deceleration range (L1, L2) for the cam curve. The range that can be set differs depending on the cam curve. When "L1 = L2 = 0", the default value for each curve is applied.
862225	Acceleration/ deceleration range compensation (Range L2) ^{*2}		

Buffer memory address	Item	Setting value	Details	
862226	Section 2	Cam curve type ^{*2}	0: Constant speed 1: Constant acceleration 2: Distorted trapezoid 3: Distorted sine 4: Distorted constant speed 5: Cycloid 6: 5th curve 7: Trapecloid 8: Reverse trapezoid 9: Double hypotenuse 10: Reverse double hypotenuse 11: Single hypotenuse	The data specified by "number of sections" becomes valid. It is not necessary to set the data after the number of sections specified.
862228 862229		End point (X2)	1 to Cam axis length per cycle [Cam axis length per cycle units] ^{*1}	
862230 862231		Stroke (Y2) ^{*4}	-2147483648 to 2147483647 [Cam stroke amount units]	
862232		Curve applicable range (P1)	0 to 100 [× 0.01]	
862233		Curve applicable range (P2)		
862234		Acceleration/deceleration range compensation (Range L1) ^{*2}	1 to 9999 [× 0.0001]	
862235		Acceleration/ deceleration range compensation (Range L2) ^{*2}		
⋮		⋮	⋮	
865806	Section 360	Cam curve type ^{*2}	0: Constant speed 1: Constant acceleration 2: Distorted trapezoid 3: Distorted sine 4: Distorted constant speed 5: Cycloid 6: 5th curve 7: Trapecloid 8: Reverse trapezoid 9: Double hypotenuse 10: Reverse double hypotenuse 11: Single hypotenuse	
865808 865809		End point (X32)	1 to Cam axis length per cycle [Cam axis length per cycle units] ^{*1}	
865810 865811		Stroke (Y32) ^{*4}	-2147483648 to 2147483647 [Cam stroke amount units]	
865812		Curve applicable range (P1)	0 to 100 [× 0.01]	
865813		Curve applicable range (P1)		
865814		Acceleration/deceleration range compensation (Range L1) ^{*2}	1 to 9999 [× 0.0001]	
865815		Acceleration/ deceleration range compensation (Range L2) ^{*2}		

- *1 If setting is outside range, the cam axis length per cycle will be set as the final end point of the section settings.
- *2 Refer to the following for the shapes of each cam type and ranges/default value for L1 and L2. Set "0" for the types of cam curves that do not use L1 and L2.
 Page 89 [Cam curve list]
- *3 The set value is only used for cam data generation. Control is performed by the output axis parameter "[Pr.439] Cam axis length per cycle" and "[Pr.441] Cam stroke amount".
- *4 When the cam stroke amount units is a unit other than "%", set the stroke amount so that "Stroke (Yn) / cam stroke amount" is inside the range of "-2.147483648 to 2.147483647".

Point 

- Set data for the number of sections specified. It is not necessary to set the data after the number of sections specified.
 - Set the end point data in ascending order.
 - Various cam patterns are created by the setting of the stroke and cam data of each section. If the amount of change in stroke is large, it may cause a servo error in the servo amplifier including overspeed, command frequency error etc. When creating cam, confirm the cam operation in amplifier-less operation.
 - Cam data will end at the section where the end point is exceeds the cam axis length per cycle set by the auto-generation data.
-

[Cam curve list]

- - - - : Stroke ratio ——— : Acceleration ■ : Range L1 ▨ : Range L2

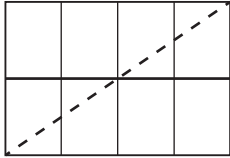
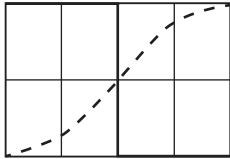
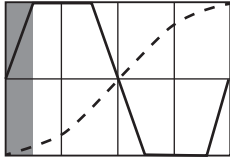
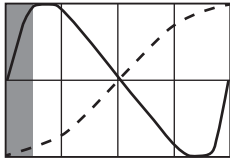
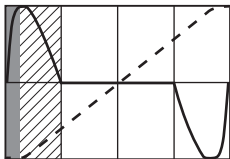
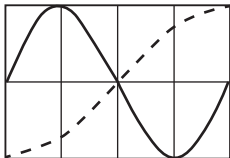
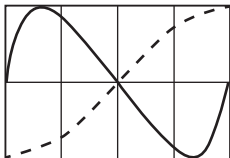
Cam curve type			Acceleration curve shape	Curve applicable range (P1 to P2)	Acceleration/deceleration range compensation (): Default value	
Setting value	Cam curve name				Range L1	Range L2
0	Constant speed	Discontinuous		0.00 to 1.00	—	—
1	Constant acceleration			0.00 to 1.00	—	—
2	Distorted trapezoid	Two-dwelling symmetrical		0.00 to 1.00	0.0001 to 0.2499 (0.1250)	—
3	Distorted sine			0.00 to 1.00	0.0001 to 0.4999 (0.1250)	—
4	Distorted constant speed			0.00 to 1.00	0.0001 to 0.1249 (0.0625)	0.0001 to 0.4999 (0.2500)
5	Cycloid			0.00 to 1.00	—	—
6	5th curve			0.00 to 1.00	—	—

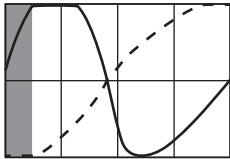
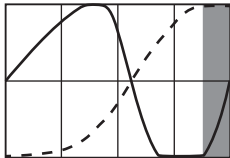
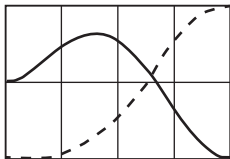
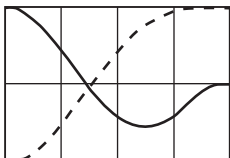
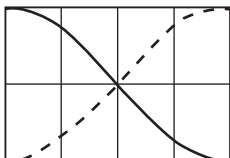
Cam curve type			Acceleration curve shape	Curve applicable range (P1 to P2)	Acceleration/deceleration range compensation (): Default value	
Setting value	Cam curve name				Range L1	Range L2
7	Trapezoid	Two-dwelling asymmetrical		0.00 to 1.00	0.0001 to 0.2499 (0.1250)	—
8	Reverse trapezoid			0.00 to 1.00	0.0001 to 0.2499 (0.1250)	—
9	Double hypotenuse	One-dwelling		0.00 to 1.00	—	—
10	Reverse double hypotenuse			0.00 to 1.00	—	—
11	Single hypotenuse	Non-dwelling curve		0.00 to 1.00	—	—

4 ADVANCED SYNCHRONOUS CONTROL

The parameters and monitor data for synchronous control such as "Main shaft module", "Speed change gear module", and "Output axis module" are explained in this chapter.

Configure the required settings according to the control and application requirements for each module.

4.1 Main Shaft Module

Overview of main shaft module

For the main shaft module, the input value is generated as a composite value from two input axes (the main and sub input axis) through the composite main shaft gear. The composite input value can be converted by the main shaft gear that provides the deceleration ratio and the rotation direction for the machine system, etc.

Refer to the followings for details on setting for the main shaft module.

☞ Page 92 Main shaft parameters, ☞ Page 94 Main shaft clutch parameters

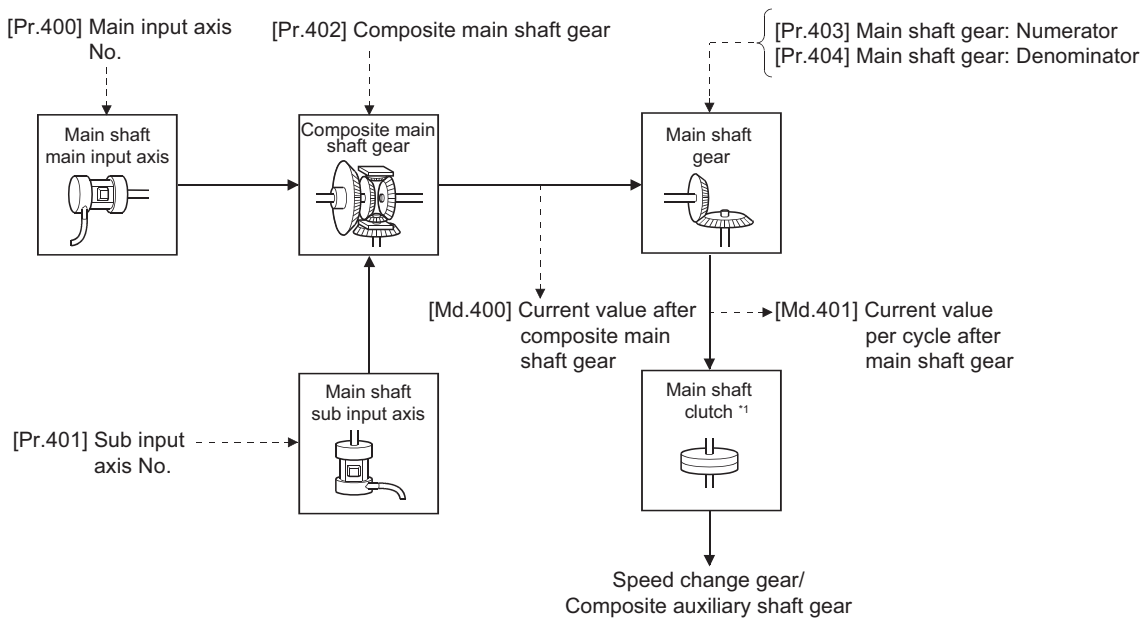

*1 ☞ Page 110 Clutch

Main shaft parameters

n: Axis No. - 1 (n: Axis No. - 17 for axis 17 to axis 32)

Setting item	Setting details	Setting value	Default value	Buffer memory address	
				Axis 1 to axis 16	Axis 17 to axis 32
[Pr.400] Main input axis No.	<ul style="list-style-type: none"> Set the input axis No. on the main input side for the main shaft. <p><u>Fetch cycle: At start of synchronous control</u></p>	<ul style="list-style-type: none"> Set in decimal. 0: Invalid 1 to 32: Servo input axis^{*1} 801 to 804: Synchronous encoder axis [RD77MS] 801 to 832: Synchronous encoder axis^{*1} [RD77GF] 	0	36400+200n	1036400+200n
[Pr.401] Sub input axis No.	<ul style="list-style-type: none"> Set the input axis No. on the sub input side for the main shaft. <p><u>Fetch cycle: At start of synchronous control</u></p>	<ul style="list-style-type: none"> Set in decimal. 0: Invalid 1 to 32: Servo input axis^{*1} 801 to 804: Synchronous encoder axis [RD77MS] 801 to 832: Synchronous encoder axis^{*1} [RD77GF] 	0	36401+200n	1036401+200n
[Pr.402] Composite main shaft gear	<ul style="list-style-type: none"> Select the composite method for input values from the main input axis and sub input axis. <p><u>Fetch cycle: Operation cycle</u></p>	<ul style="list-style-type: none"> Set in hexadecimal. <p> Main input method 0: No input 1: Input + 2: Input - Sub input method 0: No input 1: Input + 2: Input - </p>	0001H	36402+200n	1036402+200n
[Pr.403] Main shaft gear: Numerator	<ul style="list-style-type: none"> Set the numerator for the main shaft gear. <p><u>Fetch cycle: At start of synchronous control</u></p>	<ul style="list-style-type: none"> Set in decimal. -2147483648 to 2147483647 	1	36404+200n 36405+200n	1036404+200n 1036405+200n
[Pr.404] Main shaft gear: Denominator	<ul style="list-style-type: none"> Set the denominator for the main shaft gear. <p><u>Fetch cycle: At start of synchronous control</u></p>	<ul style="list-style-type: none"> Set in decimal. 1 to 2147483647 	1	36406+200n 36407+200n	1036406+200n 1036407+200n

*1 The range from axis 1 to 2 is valid in the 2-axis module, from axis 1 to 4 is valid in the 4-axis module, from axis 1 to 8 is valid in the 8-axis module, from axis 1 to 16 is valid in the 16-axis module, and from axis 1 to 32 is valid in the 32-axis module.

[Pr.400] Main input axis No., [Pr.401] Sub input axis No.

Set the main input axis No. and the sub input axis No. for the main shaft.

Setting value	Details
0: Invalid	The input value is always 0.
1 to 32: Servo input axis ^{*1}	Set the servo input axis (axis 1 to axis 32). When the servo input axis is not set in the system setting, the input value is always 0. If the No. is set to the same value as the output axis, the following errors occur and synchronous control cannot be started. <ul style="list-style-type: none"> Outside main input axis No. range (error code: 1BE0H) Outside sub input axis No. range (error code: 1BE1H)
801 to 804: Synchronous encoder axis [RD77MS] 801 to 832: Synchronous encoder axis ^{*1} [RD77GF]	Set the synchronous encoder axis (axis 1 to axis 4 [RD77MS], axis 1 to axis 32 [RD77GF]). When the synchronous encoder axis is invalid, the input value is always 0.

*1 The range from axis 1 to 2 is valid in the 2-axis module, from axis 1 to 4 is valid in the 4-axis module, from axis 1 to 8 is valid in the 8-axis module, from axis 1 to 16 is valid in the 16-axis module, and from axis 1 to 32 is valid in the 32-axis module.

[Pr.402] Composite main shaft gear

Set the composite method for input values from the main and sub input axes. The setting values for each axis are shown as follows.

Setting value	Details
0: No input	The input value from the input axis is calculated as 0.
1: Input+	The input value from the input axis is calculated as it is.
2: Input-	The input value from the input axis is calculated with its opposite sign.

Operation assumes "0: No input" if the value is set out of the range from 0 to 2.

Point

The composite method for the composite main shaft gear can be changed during synchronous control. It is used as a clutch to switch input values between the main and the sub input axes.

4

[Pr.403] Main shaft gear: Numerator, [Pr.404] Main shaft gear: Denominator

Set the numerator and the denominator for the main shaft gear to convert the input value. The input value is converted as follows.

$$\text{Input value after conversion} = \text{Input value before conversion} \times \frac{[\text{Pr.403}] \text{ Main shaft gear: Numerator}}{[\text{Pr.404}] \text{ Main shaft gear: Denominator}}$$

The input value direction can be reversed by setting a negative value in the numerator of the main shaft gear.

Set the denominator of the main shaft gear to a value within the range from 1 to 2147483647.

Ex.

Convert the cam axis per cycle to be controlled in intervals of 0.1 mm (0.00394 inch). The cam axis synchronizes with a conveyer that moves 100 mm (3.937 inch) for every (360.00000 degree) of the main shaft.

"[Pr.403] Main shaft gear: Numerator": 1000 [× 0.1 mm]

"[Pr.404] Main shaft gear: Denominator": 36000000 [× 10⁻⁵ degree]

Main shaft clutch parameters

n: Axis No. - 1 (n: Axis No. - 17 for axis 17 to axis 32)

Setting item	Setting details	Setting value	Default value	Buffer memory address	
				Axis 1 to axis 16	Axis 17 to axis 32
[Pr.405] Main shaft clutch control setting	<ul style="list-style-type: none"> Set the control method for the clutch. <p>Fetch cycle: <u>Operation cycle</u></p>	<p>■Set in hexadecimal.</p> <p>H</p> <ul style="list-style-type: none"> ON control mode <ul style="list-style-type: none"> 0: No clutch 1: Clutch command ON/OFF 2: Clutch command leading edge 3: Clutch command trailing edge 4: Address mode 5: High speed input request [RD77MS] 6: Main shaft clutch control request ON/OFF [RD77GF] 7: Main shaft clutch control request leading edge [RD77GF] 8: Main shaft clutch control request trailing edge [RD77GF] OFF control mode <ul style="list-style-type: none"> 0: OFF control invalid 1: One-shot OFF 2: Clutch command leading edge 3: Clutch command trailing edge 4: Address mode 5: High speed input request [RD77MS] 7: Main shaft clutch control request leading edge [RD77GF] 8: Main shaft clutch control request trailing edge [RD77GF] High speed input request signal <ul style="list-style-type: none"> 0 to F: High speed input request signal from axis 1 to axis 16^{*1} [RD77MS] 	0000H	36408+200n	1036408+200n
[Pr.406] Main shaft clutch reference address setting	<ul style="list-style-type: none"> Set the reference address for the clutch. <p>Fetch cycle: <u>At start of synchronous control</u></p>	<p>■Set in decimal.</p> <ul style="list-style-type: none"> 0: Current value after composite main shaft gear 1: Current value per cycle after main shaft gear 	0	36409+200n	1036409+200n
[Pr.407] Main shaft clutch ON address	<ul style="list-style-type: none"> Set the clutch ON address for address mode. (This setting is invalid except during address mode.) If the address is out of the range from 0 to (Cam axis length per cycle - 1), the address is converted to a value within range. <p>Fetch cycle: <u>Operation cycle</u></p>	<p>■Set in decimal.</p> <p>-2147483648 to 2147483647 [Main input axis position units^{*2}, or cam axis cycle units^{*3}]</p>	0	36410+200n 36411+200n	1036410+200n 1036411+200n
[Pr.408] Movement amount before main shaft clutch ON	<ul style="list-style-type: none"> Set the movement amount between the clutch ON condition completing and the clutch closing. Set a positive value when the reference address is increasing, and a negative value when it is decreasing. <p>Fetch cycle: <u>At completing clutch ON condition</u></p>	<p>■Set in decimal.</p> <p>-2147483648 to 2147483647 [Main input axis position units^{*2}, or cam axis cycle units^{*3}]</p>	0	36412+200n 36413+200n	1036412+200n 1036413+200n

Setting item	Setting details	Setting value	Default value	Buffer memory address	
				Axis 1 to axis 16	Axis 17 to axis 32
[Pr.409] Main shaft clutch OFF address	<ul style="list-style-type: none"> Set the clutch OFF address for the address mode. (This setting is invalid except during address mode.) If the address is out of the range from 0 to (Cam axis length per cycle - 1), the address is converted to a value within range. Fetch cycle: Operation cycle	■Set in decimal. -2147483648 to 2147483647 [Main input axis position units ^{*2} , or cam axis cycle units ^{*3}]	0	36414+200n 36415+200n	1036414+200n 1036415+200n
[Pr.410] Movement amount before main shaft clutch OFF	<ul style="list-style-type: none"> Set the movement amount between the clutch OFF condition completing and the clutch opening. Set a positive value when the reference address is increasing, and a negative value when it is decreasing. Fetch cycle: At completing clutch OFF condition	■Set in decimal. -2147483648 to 2147483647 [Main input axis position units ^{*2} , or cam axis cycle units ^{*3}]	0	36416+200n 36417+200n	1036416+200n 1036417+200n
[Pr.411] Main shaft clutch smoothing method	<ul style="list-style-type: none"> Set the clutch smoothing method. Fetch cycle: At start of synchronous control	■Set in decimal. 0: Direct 1: Time constant method (Exponent) 2: Time constant method (Linear) 3: Slippage method (Exponent) 4: Slippage method (Linear) 5: Slippage method (Linear: Input value follow up)	0	36418+200n	1036418+200n
[Pr.412] Main shaft clutch smoothing time constant	<ul style="list-style-type: none"> For smoothing with a time constant method, set the smoothing time constant. Fetch cycle: At start of synchronous control	■Set in decimal. 0 to 5000 [ms]	0	36419+200n	1036419+200n
[Pr.413] Slippage amount at main shaft clutch ON	<ul style="list-style-type: none"> For smoothing with a slippage method, set the slippage amount at clutch ON. Fetch cycle: At turning clutch ON	■Set in decimal. 0 to 2147483647 [Main input axis position units ^{*2} , or cam axis cycle units ^{*3}]	0	36420+200n 36421+200n	1036420+200n 1036421+200n
[Pr.414] Slippage amount at main shaft clutch OFF	<ul style="list-style-type: none"> For smoothing with a slippage method, set the slippage amount at clutch OFF. Fetch cycle: At turning clutch OFF	■Set in decimal. 0 to 2147483647 [Main input axis position units ^{*2} , or cam axis cycle units ^{*3}]	0	36422+200n 36423+200n	1036422+200n 1036423+200n

*1 The range from axis 1 to 2 is valid in the 2-axis module, from axis 1 to 4 is valid in the 4-axis module, from axis 1 to 8 is valid in the 8-axis module, and from 1 to 16 is valid in the 16-axis module.

*2 Main input axis position units (☞ Page 28 INPUT AXIS MODULE)

*3 Cam axis cycle units (☞ Page 126 Units for the output axis)

[Pr.405] Main shaft clutch control setting

Set the ON and OFF control methods separately for the main shaft clutch.

The clutch control setting can be changed during synchronous control, however, the setting "No clutch" (Direct coupled operation) cannot be selected during synchronous control after already selecting another setting.

Refer to the following for operation details on the clutch control.

 Page 110 Control method for clutch

■ON control mode

Setting value	Details
0: No clutch (Direct coupled operation)	Execute direct coupled operation without clutch control.
1: Clutch command ON/OFF	The clutch is turned ON/OFF by the operation of "[Cd.400] Main shaft clutch command" ON/OFF. (Setting in the OFF control mode are not applicable in this mode.)
2: Clutch command leading edge	The clutch is turned ON when "[Cd.400] Main shaft clutch command" passes the leading edge (from OFF to ON).
3: Clutch command trailing edge	The clutch is turned ON when "[Cd.400] Main shaft clutch command" passes the trailing edge (from ON to OFF).
4: Address mode	The clutch is turned ON when the reference address (the current value after composite main shaft gear or the current value per cycle after main shaft gear) reaches "[Pr.407] Main shaft clutch ON address". The movement amount after passing through the ON address is calculated as the output movement amount of the clutch based on the reference address passing through, thereby controlling the clutch with an accurate movement amount.
5: High speed input request [RD77MS]	The clutch is turned ON when the high speed input request [DI] turns ON.
6: Main shaft clutch control request ON/OFF [RD77GF]	The clutch is turned ON/OFF by ON/OFF operation of the link device assigned to the main shaft clutch control request by the link device external signal assignment function. (Setting in the OFF control mode are not applicable in this mode.)
7: Main shaft clutch control request leading edge [RD77GF]	The clutch is turned ON when the link device assigned to the main shaft clutch control request by the link device external signal assignment function passes the leading edge (from OFF to ON).
8: Main shaft clutch control request trailing edge [RD77GF]	The clutch is turned ON when the link device assigned to the main shaft clutch control request by the link device external signal assignment function passes the trailing edge (from ON to OFF).

Point

Other clutch parameters are not applicable during direct coupled operation by setting "0: No clutch". "[Cd.402] Main shaft clutch forced OFF command" and the change of the clutch control setting are ignored during direct coupled operation.

■OFF control mode

Setting value	Details
0: OFF control invalid	Clutch OFF control is not used. This setting is applicable only for execution with clutch ON control.
1: One-shot OFF	The clutch is turned OFF after moving the distance "[Pr.410] Movement amount before main shaft clutch OFF" (One-shot operation) after the clutch command turns ON. If "[Pr.410] Movement amount before main shaft clutch OFF" is 0, "[Md.420] Main shaft clutch ON/OFF status" does not turn ON in order to turn back OFF immediately.
2: Clutch command leading edge	The clutch is turned OFF when "[Cd.400] Main shaft clutch command" passes the leading edge (from OFF to ON).
3: Clutch command trailing edge	The clutch is turned OFF when "[Cd.400] Main shaft clutch command" passes the trailing edge (from ON to OFF).
4: Address mode	The clutch is turned OFF when the reference address (the current value after composite main shaft gear or the current value per cycle after main shaft gear) reaches "[Pr.409] Main shaft clutch OFF address". The movement amount before passing through the OFF address is calculated as the output movement amount of the clutch based on the reference address passing through, thereby controlling the clutch with an accurate movement amount.
5: High speed input request [RD77MS]	The clutch is turned OFF when the high speed input request [DI] turns ON.
7: Main shaft clutch control request leading edge [RD77GF]	The clutch is turned OFF when the link device assigned to the main shaft clutch control request by the link device external signal assignment function passes the leading edge (from OFF to ON).
8: Main shaft clutch control request trailing edge [RD77GF]	The clutch is turned OFF when the link device assigned to the main shaft clutch control request by the link device external signal assignment function passes the trailing edge (from ON to OFF).

■High speed input request signal [RD77MS]

Set the high speed input request signal No. for the ON control mode (1) and the OFF control mode (2) when using the setting "5: High speed input request".

Signal No.	Setting value (Hexadecimal)	Signal No.	Setting value (Hexadecimal)	Signal No.	Setting value (Hexadecimal)	Signal No.	Setting value (Hexadecimal)
1	0	5	4	9	8	13	C
2	1	6	5	10	9	14	D
3	2	7	6	11	A	15	E
4	3	8	7	12	B	16	F

[Pr.406] Main shaft clutch reference address setting

Select the address type to be used as the reference address for clutch control. Note that the processing order of the main shaft gear and the main shaft clutch will change depending on the reference address setting.

Setting value	Details
0: Current value after composite main shaft gear	The clutch is controlled by using the current value after composite main shaft gear as a reference. Output after the clutch is a converted movement amount through the main shaft gear.
1: Current value per cycle after main shaft gear	The clutch is controlled by using the current value per cycle after main shaft gear. Output after the clutch is a movement amount without conversion.

The setting values for the following parameters are in units based on the reference address setting.

- "[Pr.407] Main shaft clutch ON address"
- "[Pr.409] Main shaft clutch OFF address"
- "[Pr.408] Movement amount before main shaft clutch ON", "[Pr.410] Movement amount before main shaft clutch OFF"
- "[Pr.413] Slippage amount at main shaft clutch ON", "[Pr.414] Slippage amount at main shaft clutch OFF"

[Pr.407] Main shaft clutch ON address

Set the clutch ON address when address mode is configured for the ON control mode of the main shaft clutch.

When the reference address is the current value per cycle after main shaft gear, the setting address is converted for control within the range from 0 to (Cam axis length per cycle - 1).

Ex.

Cam axis length per cycle: 20000 pulses

The ON address is controlled as 19000 pulses when the setting value is "-1000".

[Pr.408] Movement amount before main shaft clutch ON

Set the movement amount of the reference address with a signed value between the clutch ON condition completing and the clutch closing.

Setting value	Details
1 to 2147483647 (Positive value)	Used when the reference address is increasing in direction.
0	No movement amount (The clutch is immediately turned ON with the clutch ON condition completing.)
-2147483648 to -1 (Negative value)	Used when the reference address is decreasing in direction.

Clutch ON condition is completed
(Example: [Cd.400] Main shaft clutch command ON)

[Md.420] Main shaft clutch ON/OFF status

[Md.400] Current value after composite main shaft gear or

[Md.401] Current value per cycle after main shaft gear

Movement amount after clutch

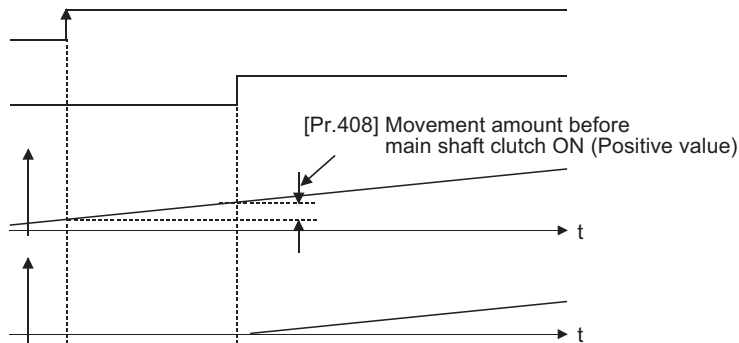

[Pr.409] Main shaft clutch OFF address

Set the clutch OFF address when address mode is configured for the OFF control mode of the main shaft clutch.

When the reference address is the current value per cycle after main shaft gear, the setting address is converted for control within the range from 0 to (Cam axis length per cycle - 1).

Ex.

Cam axis length per cycle: 20000 pulses

The OFF address is controlled as 60 pulses when the setting value is "40060".

[Pr.410] Movement amount before main shaft clutch OFF

Set the movement amount of the reference address with a signed value between the clutch OFF condition completing and the clutch opening.

Setting value	Details
1 to 2147483647 (Positive value)	Used when the reference address is increasing in direction.
0	No movement amount (The clutch is immediately turned OFF with the clutch OFF condition completing.)
-2147483648 to -1 (Negative value)	Used when the reference address is decreasing in direction.

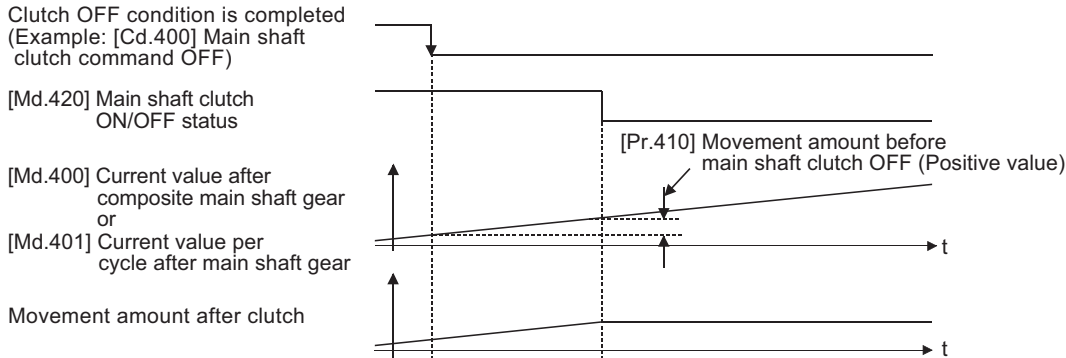

[Pr.411] Main shaft clutch smoothing method

Set the smoothing method for clutch ON/OFF.

Refer to the following.

☞ Page 117 Smoothing method for clutch

Setting value	Details
0: Direct	No smoothing
1: Time constant method (Exponent)	Smoothing with an exponential curve based on the time constant setting.
2: Time constant method (Linear)	Smoothing with linear acceleration/deceleration based on the time constant setting.
3: Slippage method (Exponent)	Smoothing with an exponential curve based on the slippage amount setting.
4: Slippage method (Linear)	Smoothing with linear acceleration/deceleration based on the slippage amount setting.
5: Slippage method (Linear: Input value follow up)	Smoothing with linear acceleration/deceleration based on the slippage amount setting (input value follow up).

[Pr.412] Main shaft clutch smoothing time constant

Set a time constant when the time constant method is set in "[Pr.411] Main shaft clutch smoothing method".

The time constant setting applies for clutch ON/OFF.

[Pr.413] Slippage amount at main shaft clutch ON

Set the slippage amount at clutch ON when the slippage method is set in "[Pr.411] Main shaft clutch smoothing method". The slippage amount is set in units based on the current value selected in "[Pr.406] Main shaft clutch reference address setting".

If the set amount is negative, slippage amount at clutch ON is controlled as 0 (direct).

[Pr.414] Slippage amount at main shaft clutch OFF

Set the slippage amount at clutch OFF when the slippage method is set in "[Pr.411] Main shaft clutch smoothing method". The slippage amount is set in units based on the current value selected in "[Pr.406] Main shaft clutch reference address setting".

If the set amount is negative, slippage amount at clutch OFF is controlled as 0 (direct).

Main shaft clutch control data

n: Axis No. - 1 (n: Axis No. - 17 for axis 17 to axis 32)

Setting item	Setting details	Setting value	Default value	Buffer memory address	
				Axis 1 to axis 16	Axis 17 to axis 32
[Cd.400] Main shaft clutch command	<ul style="list-style-type: none"> Set the clutch command ON/OFF. Fetch cycle: <u>Operation cycle</u>	■Set in decimal. 0: Main shaft clutch command OFF 1: Main shaft clutch command ON	0	44080+20n	1044080+20n
[Cd.401] Main shaft clutch control invalid command	<ul style="list-style-type: none"> Set "1" to disable the clutch control temporarily. Fetch cycle: <u>Operation cycle</u>	■Set in decimal. 0: Main shaft clutch control valid 1: Main shaft clutch control invalid	0	44081+20n	1044081+20n
[Cd.402] Main shaft clutch forced OFF command	<ul style="list-style-type: none"> Set "1" to force the clutch OFF. Fetch cycle: <u>Operation cycle</u>	■Set in decimal. 0: Main shaft clutch normal control 1: Main shaft clutch forced OFF	0	44082+20n	1044082+20n

[Cd.400] Main shaft clutch command

Set ON/OFF for the main shaft clutch command. This command is used when the clutch ON control mode is "1: Clutch command ON/OFF", "2: Clutch command leading edge" or "3: Clutch command trailing edge" and the clutch OFF control mode is "2: Clutch command leading edge" or "3: Clutch command trailing edge".

Status is considered as clutch command OFF just before starting synchronous control. If synchronous control is started while the clutch command is ON, the condition is established just after starting synchronous control, by setting "2: Clutch command leading edge". The condition is not established just after starting, by setting "3: Clutch command trailing edge".

[Cd.401] Main shaft clutch control invalid command

The main shaft clutch control is invalid if "1" is set. The previous clutch ON/OFF status remains before clutch control becomes invalid.

Clutch control will not become invalid during the movement before clutch ON and clutch OFF. Instead, clutch control will become invalid after movement is completed.

[Cd.402] Main shaft clutch forced OFF command

Set "1" to force the clutch OFF. The output value from the clutch becomes 0 immediately, even during clutch smoothing. The slippage (accumulative) amount is set to 0 if smoothing with a slippage method.

Reset to "0" to restart the clutch control from the clutch OFF status after using the clutch forced OFF command.

4.2 Auxiliary Shaft Module

Overview of auxiliary shaft module

For the auxiliary shaft module, the input value is generated from the auxiliary shaft. The input value can be converted by the auxiliary shaft gear that provides the deceleration ratio and the rotation direction for the machine system, etc. Refer to the followings for details on setting for the auxiliary shaft module.

☞ Page 101 Auxiliary shaft parameters, ☞ Page 103 Auxiliary shaft clutch parameters

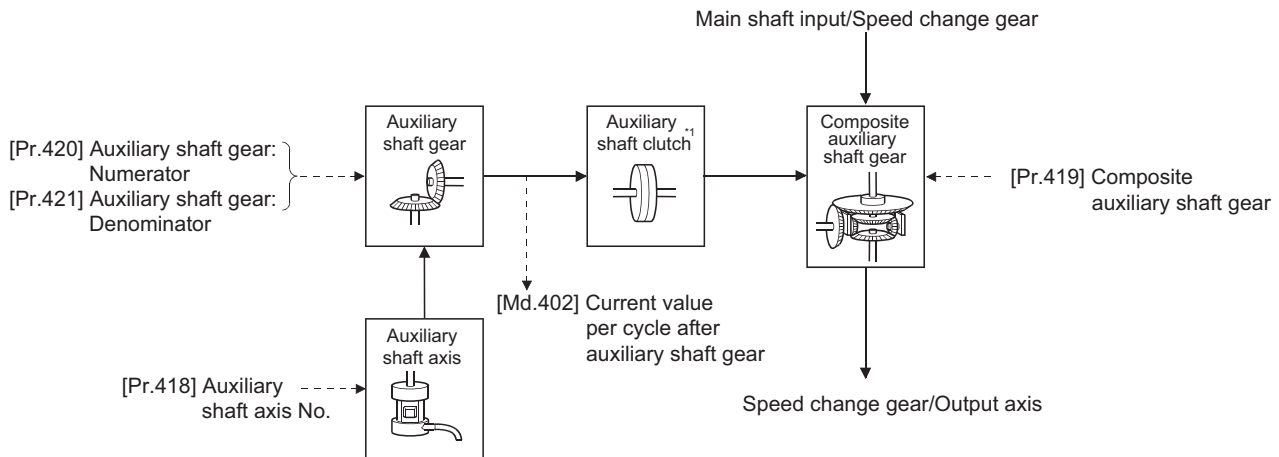

*1 ☞ Page 110 Clutch

Auxiliary shaft parameters

n: Axis No. - 1 (n: Axis No. - 17 for axis 17 to axis 32)

Setting item	Setting details	Setting value	Default value	Buffer memory address	
				Axis 1 to axis 16	Axis 17 to axis 32
[Pr.418] Auxiliary shaft axis No.	<ul style="list-style-type: none"> Set the input axis No. for the auxiliary shaft. <u>Fetch cycle: At start of synchronous control</u>	<ul style="list-style-type: none"> Set in decimal. 0: Invalid 1 to 32: Servo input axis*1 801 to 804: Synchronous encoder axis [RD77MS] 801 to 832: Synchronous encoder axis*1 [RD77GF] 	0	36430+200n	1036430+200n
[Pr.419] Composite auxiliary shaft gear	<ul style="list-style-type: none"> Select the composite method for input values from the main shaft and the auxiliary shaft. <u>Fetch cycle: Operation cycle</u>	<ul style="list-style-type: none"> Set in hexadecimal. <div style="border: 1px solid black; padding: 5px; margin: 5px 0;"> <p>H</p> <p>├── Main shaft input method</p> <p>│ 0: No input</p> <p>│ 1: Input +</p> <p>│ 2: Input -</p> <p>└── Auxiliary shaft input method</p> <p> 0: No input</p> <p> 1: Input +</p> <p> 2: Input -</p> </div>	0001H	36431+200n	1036431+200n
[Pr.420] Auxiliary shaft gear: Numerator	<ul style="list-style-type: none"> Set the numerator for the auxiliary shaft gear. <u>Fetch cycle: At start of synchronous control</u>	<ul style="list-style-type: none"> Set in decimal. -2147483648 to 2147483647 	1	36432+200n 36433+200n	1036432+200n 1036433+200n
[Pr.421] Auxiliary shaft gear: Denominator	<ul style="list-style-type: none"> Set the denominator for the auxiliary shaft gear. <u>Fetch cycle: At start of synchronous control</u>	<ul style="list-style-type: none"> Set in decimal. 1 to 2147483647 	1	36434+200n 36435+200n	1036434+200n 1036435+200n

*1 The range from axis 1 to 2 is valid in the 2-axis module, from axis 1 to 4 is valid in the 4-axis module, from axis 1 to 8 is valid in the 8-axis module, from axis 1 to 16 is valid in the 16-axis module, and from axis 1 to 32 is valid in the 32-axis module.

[Pr.418] Auxiliary shaft axis No.

Set the input axis No. for the auxiliary shaft.

Setting value	Details
0: Invalid	The input value is always 0.
1 to 32: Servo input axis*1	Set the servo input axis (axis 1 to axis 32). When the servo input axis is not set in the system setting, the input value is always 0. If the No. is set to the same value as the output axis, the error "Outside auxiliary shaft No. range" (error code: 1BF0H) occurs and synchronous control cannot be started.
801 to 804: Synchronous encoder axis [RD77MS] 801 to 832: Synchronous encoder axis*1 [RD77GF]	Set the synchronous encoder axis (axis 1 to axis 4 [RD77MS], axis 1 to axis 32 [RD77GF]). When the synchronous encoder axis is invalid, the input value is always 0.

*1 The range from axis 1 to 2 is valid in the 2-axis module, from axis 1 to 4 is valid in the 4-axis module, from axis 1 to 8 is valid in the 8-axis module, from axis 1 to 16 is valid in the 16-axis module, and from axis 1 to 32 is valid in the 32-axis module.

[Pr.419] Composite auxiliary shaft gear

Set the composite method for input values from the main and auxiliary shafts. The setting values for each axis are shown as follows.

Setting value	Details
0: No input	The input value from the input axis is calculated as 0.
1: Input+	The input value from the input axis is calculated as it is.
2: Input-	The input value from the input axis is calculated with its opposite sign.

Operation assumes "0: No input" if the value is set out of the range from 0 to 2.

Point

The composite method for the composite auxiliary shaft gear can be changed during synchronous control. It is used as a clutch to switch input values between the main and the auxiliary shafts.

[Pr.420] Auxiliary shaft gear: Numerator, [Pr.421] Auxiliary shaft gear: Denominator

Set the numerator and the denominator for auxiliary shaft gear to convert the input value. The input value is converted as follows.

$$\text{Input value after conversion} = \text{Input value before conversion} \times \frac{[\text{Pr.420}] \text{ Auxiliary shaft gear: Numerator}}{[\text{Pr.421}] \text{ Auxiliary shaft gear: Denominator}}$$

The input value direction can be reversed by setting a negative value in the numerator of the auxiliary shaft gear.

Set the denominator of the auxiliary shaft gear to a value within the range from 1 to 2147483647.

Auxiliary shaft clutch parameters

n: Axis No. - 1 (n: Axis No. - 17 for axis 17 to axis 32)

Setting item	Setting details	Setting value	Default value	Buffer memory address	
				Axis 1 to axis 16	Axis 17 to axis 32
[Pr.422] Auxiliary shaft clutch control setting	<ul style="list-style-type: none"> Set the control method for the clutch. <p><u>Fetch cycle: Operation cycle</u></p>	<p>■Set in hexadecimal.</p> <p>H</p> <ul style="list-style-type: none"> ON control mode <ul style="list-style-type: none"> 0: No clutch 1: Clutch command ON/OFF 2: Clutch command leading edge 3: Clutch command trailing edge 4: Address mode 5: High speed input request [RD77MS] 6: Auxiliary shaft clutch control request ON/OFF [RD77GF] 7: Auxiliary shaft clutch control request leading edge [RD77GF] 8: Auxiliary shaft clutch control request trailing edge [RD77GF] OFF control mode <ul style="list-style-type: none"> 0: OFF control invalid 1: One-shot OFF 2: Clutch command leading edge 3: Clutch command trailing edge 4: Address mode 5: High speed input request [RD77MS] 7: Auxiliary shaft clutch control request leading edge [RD77GF] 8: Auxiliary shaft clutch control request trailing edge [RD77GF] High speed input request signal <ul style="list-style-type: none"> 0 to F: High speed input request signal from axis 1 to axis 16¹ [RD77MS] 	0000H	36436+200n	1036436+200n
[Pr.423] Auxiliary shaft clutch reference address setting	<ul style="list-style-type: none"> Set the reference address for the clutch. <p><u>Fetch cycle: At start of synchronous control</u></p>	<p>■Set in decimal.</p> <ul style="list-style-type: none"> 0: Auxiliary shaft current value 1: Current value per cycle after auxiliary shaft gear 	0	36437+200n	1036437+200n
[Pr.424] Auxiliary shaft clutch ON address	<ul style="list-style-type: none"> Set the clutch ON address for address mode. (This setting is invalid except during address mode.) If the address is out of the range from 0 to (Cam axis length per cycle - 1), the address is converted to a value within range. <p><u>Fetch cycle: Operation cycle</u></p>	<p>■Set in decimal.</p> <p>-2147483648 to 2147483647 [Auxiliary shaft position units², or cam axis cycle units³]</p>	0	36438+200n 36439+200n	1036438+200n 1036439+200n
[Pr.425] Movement amount before auxiliary shaft clutch ON	<ul style="list-style-type: none"> Set the movement amount between the clutch ON condition completing and the clutch closing. Set the movement amount between the clutch ON condition completing and the clutch closing. <p><u>Fetch cycle: At completing clutch ON condition</u></p>	<p>■Set in decimal.</p> <p>-2147483648 to 2147483647 [Auxiliary shaft position units², or cam axis cycle units³]</p>	0	36440+200n 36441+200n	1036440+200n 1036441+200n

Setting item	Setting details	Setting value	Default value	Buffer memory address	
				Axis 1 to axis 16	Axis 17 to axis 32
[Pr.426] Auxiliary shaft clutch OFF address	<ul style="list-style-type: none"> Set the clutch OFF address for the address mode. (This setting is invalid except during address mode.) If the address is out of the range from 0 to (Cam axis length per cycle - 1), the address is converted to a value within range. Fetch cycle: Operation cycle	■Set in decimal. -2147483648 to 2147483647 [Auxiliary shaft position units ^{*2} , or cam axis cycle units ^{*3}]	0	36442+200n 36443+200n	1036442+200n 1036443+200n
[Pr.427] Movement amount before auxiliary shaft clutch OFF	<ul style="list-style-type: none"> Set the movement amount between the clutch OFF condition completing and the clutch opening. Set a positive value when the reference address is increasing, and a negative value when it is decreasing. Fetch cycle: At completing clutch OFF condition	■Set in decimal. -2147483648 to 2147483647 [Auxiliary shaft position units ^{*2} , or cam axis cycle units ^{*3}]	0	36444+200n 36445+200n	1036444+200n 1036445+200n
[Pr.428] Auxiliary shaft clutch smoothing method	<ul style="list-style-type: none"> Set the clutch smoothing method. Fetch cycle: At start of synchronous control	■Set in decimal. 0: Direct 1: Time constant method (Exponent) 2: Time constant method (Linear) 3: Slippage method (Exponent) 4: Slippage method (Linear) 5: Slippage method (Linear: Input value follow up)	0	36446+200n	1036446+200n
[Pr.429] Auxiliary shaft clutch smoothing time constant	<ul style="list-style-type: none"> For smoothing with a time constant method, set the smoothing time constant. Fetch cycle: At start of synchronous control	■Set in decimal. 0 to 5000 [ms]	0	36447+200n	1036447+200n
[Pr.430] Slippage amount at auxiliary shaft clutch ON	<ul style="list-style-type: none"> For smoothing with a slippage method, set the slippage amount at clutch ON. Fetch cycle: At turning clutch ON	■Set in decimal. 0 to 2147483647 [Auxiliary shaft position units ^{*2} , or cam axis cycle units ^{*3}]	0	36448+200n 36449+200n	1036448+200n 1036449+200n
[Pr.431] Slippage amount at auxiliary shaft clutch OFF	<ul style="list-style-type: none"> For smoothing with a slippage method, set the slippage amount at clutch OFF. Fetch cycle: At turning clutch OFF	■Set in decimal. 0 to 2147483647 [Auxiliary shaft position units ^{*2} , or cam axis cycle units ^{*3}]	0	36450+200n 36451+200n	1036450+200n 1036451+200n

*1 The range from axis 1 to 2 is valid in the 2-axis module, from axis 1 to 4 is valid in the 4-axis module, from axis 1 to 8 is valid in the 8-axis module, and from 1 to 16 is valid in the 16-axis module.

*2 Auxiliary shaft position units ( Page 28 INPUT AXIS MODULE)

*3 Cam axis cycle units ( Page 126 Units for the output axis)

[Pr.422] Auxiliary shaft clutch control setting

Set the ON and OFF control methods separately for the auxiliary shaft.

The clutch control setting can be changed during synchronous control, however, the setting "No clutch" (Direct coupled operation) cannot be selected during synchronous control after already selecting another setting.

Refer to the following for operation details on the clutch control.

 Page 110 Control method for clutch

■ON control mode

Setting value	Details
0: No clutch (Direct coupled operation)	Execute direct coupled operation without clutch control.
1: Clutch command ON/OFF	The clutch is turned ON/OFF by the operation of "[Cd.403] Auxiliary shaft clutch command" ON/OFF. (Setting in the OFF control mode are not applicable in this mode.)
2: Clutch command leading edge	The clutch is turned ON when "[Cd.403] Auxiliary shaft clutch command" passes the leading edge (from OFF to ON).
3: Clutch command trailing edge	The clutch is turned ON when "[Cd.403] Auxiliary shaft clutch command" passes the trailing edge (from ON to OFF).
4: Address mode	The clutch is turned ON when the reference address (the auxiliary shaft current value or the current value per cycle after auxiliary shaft gear) reaches "[Pr.424] Auxiliary shaft clutch ON address". The movement amount after passing through the ON address is calculated as the output movement amount of the clutch based on the reference address passing through, thereby controlling the clutch with an accurate movement amount.
5: High speed input request [RD77MS]	The clutch is turned ON when the high speed input request [DI] turns ON.
6: Auxiliary shaft clutch control request ON/OFF [RD77GF]	The clutch is turned ON/OFF by ON/OFF operation of the link device assigned to the auxiliary shaft clutch control request by the link device external signal assignment function. (Setting in the OFF control mode are not applicable in this mode.)
7: Auxiliary shaft clutch control request leading edge [RD77GF]	The clutch is turned ON when the link device assigned to the auxiliary shaft clutch control request by the link device external signal assignment function passes the leading edge (from OFF to ON).
8: Auxiliary shaft clutch control request trailing edge [RD77GF]	The clutch is turned ON when the link device assigned to the auxiliary shaft clutch control request by the link device external signal assignment function passes the trailing edge (from ON to OFF).

Point

Other clutch parameters are not applicable during direct coupled operation by setting "0: No clutch". "[Cd.405] Auxiliary shaft clutch forced OFF command" and the change of the clutch control setting are ignored during direct coupled operation.

■OFF control mode

Setting value	Details
0: OFF control invalid	Clutch OFF control is not used. This setting is applicable only for execution with clutch ON control.
1: One-shot OFF	The clutch is turned OFF after moving the distance "[Pr.427] Movement amount before auxiliary shaft clutch OFF" (One-shot operation) after the clutch command turns ON. If "[Pr.427] Movement amount before auxiliary shaft clutch OFF" is 0, "[Md.423] Auxiliary shaft clutch ON/OFF status" does not turn ON in order to turn back OFF immediately.
2: Clutch command leading edge	The clutch is turned OFF when "[Cd.403] Auxiliary shaft clutch command" passes the leading edge (from OFF to ON).
3: Clutch command trailing edge	The clutch is turned OFF when "[Cd.403] Auxiliary shaft clutch command" passes the trailing edge (from ON to OFF).
4: Address mode	The clutch is turned OFF when the reference address (the auxiliary shaft current value or the current value per cycle after auxiliary shaft gear) reaches "[Pr.426] Auxiliary shaft clutch OFF address". The movement amount before passing through the OFF address is calculated as the output movement amount of the clutch based on the reference address passing through, thereby controlling the clutch with an accurate movement amount.
5: High speed input request [RD77MS]	The clutch is turned OFF when the high speed input request [DI] turns ON.
7: Auxiliary shaft clutch control request leading edge [RD77GF]	The clutch is turned OFF when the link device assigned to the auxiliary shaft clutch control request by the link device external signal assignment function passes the leading edge (from OFF to ON).
8: Auxiliary shaft clutch control request trailing edge [RD77GF]	The clutch is turned OFF when the link device assigned to the auxiliary shaft clutch control request by the link device external signal assignment function passes the trailing edge (from ON to OFF).

■High speed input request signal [RD77MS]

Set the high speed input request signal No. for the ON control mode (1) and the OFF control mode (2) when using the setting "5: High speed input request"

Signal No.	Setting value (Hexadecimal)	Signal No.	Setting value (Hexadecimal)	Signal No.	Setting value (Hexadecimal)	Signal No.	Setting value (Hexadecimal)
1	0	5	4	9	8	13	C
2	1	6	5	10	9	14	D
3	2	7	6	11	A	15	E
4	3	8	7	12	B	16	F

[Pr.423] Auxiliary shaft clutch reference address setting

Select the address type to be used as the reference address for clutch control. Note that the processing order of the auxiliary shaft gear and the auxiliary shaft clutch will change depending on the reference address setting.

Setting value	Details
0: Auxiliary shaft current value	The clutch is controlled by using the current value for the servo input axis/synchronous encoder axis that is set for the auxiliary shaft. Output after the clutch is a converted movement amount through the auxiliary shaft gear.
1: Current value per cycle after auxiliary shaft gear	The clutch is controlled by using the current value per cycle after auxiliary shaft gear. Output after the clutch is a movement amount without conversion.

The setting values for the following parameters are in units based on the reference address setting.

- "[Pr.424] Auxiliary shaft clutch ON address"
- "[Pr.426] Auxiliary shaft clutch OFF address"
- "[Pr.425] Movement amount before auxiliary shaft clutch ON", "[Pr.427] Movement amount before auxiliary shaft clutch OFF"
- "[Pr.430] Slippage amount at auxiliary shaft clutch ON", "[Pr.431] Slippage amount at auxiliary shaft clutch OFF"

[Pr.424] Auxiliary shaft clutch ON address

Set the clutch ON address when address mode is configured for the ON control mode of the auxiliary shaft clutch. When the reference address is the current value per cycle after auxiliary shaft gear, the setting address is converted for control within the range from 0 to (Cam axis length per cycle - 1).

Ex.

Cam axis length per cycle: 20000 pulses

The ON address is controlled as 19000 pulses when the setting value is "-1000".

[Pr.425] Movement amount before auxiliary shaft clutch ON

Set the movement amount of the reference address with a signed value between the clutch ON condition completing and the clutch closing.

Setting value	Details
1 to 2147483647 (Positive value)	Used when the reference address is increasing in direction.
0	No movement amount (The clutch is immediately turned ON with the clutch ON condition completing.)
-2147483648 to -1 (Negative value)	Used when the reference address is decreasing in direction.

Clutch ON condition is completed
(Example: [Cd.403] Auxiliary shaft clutch command ON)

[Md.423] Auxiliary shaft clutch ON/OFF status

Auxiliary shaft current value or [Md.402] Current value per cycle after auxiliary shaft gear

Movement amount after clutch

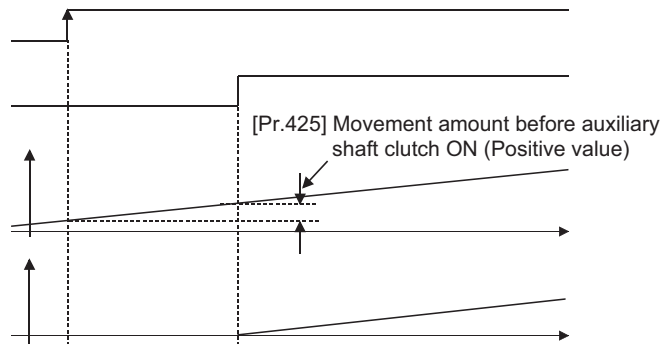

[Pr.426] Auxiliary shaft clutch OFF address

Set the clutch OFF address when address mode is configured for the OFF control mode of the auxiliary shaft clutch. When the reference address is the current value per cycle after auxiliary shaft gear, the setting address is converted for control within the range from 0 to (Cam axis length per cycle - 1).

Ex.

Cam axis length per cycle: 20000 pulses

The OFF address is controlled as 60 pulses when the setting value is "40060".

[Pr.427] Movement amount before auxiliary shaft clutch OFF

Set the movement amount of the reference address with a signed value between the clutch OFF condition completing and the clutch opening.

Setting value	Details
1 to 2147483647 (Positive value)	Used when the reference address is increasing in direction.
0	No movement amount (The clutch is immediately turned OFF with the clutch OFF condition completing.)
-2147483648 to -1 (Negative value)	Used when the reference address is decreasing in direction.

Clutch OFF condition is completed
(Example: [Cd.403] Auxiliary shaft clutch command OFF)

[Md.423] Auxiliary shaft clutch ON/OFF status

Auxiliary shaft current value or [Md.402] Current value per cycle after auxiliary shaft gear

Movement amount after clutch

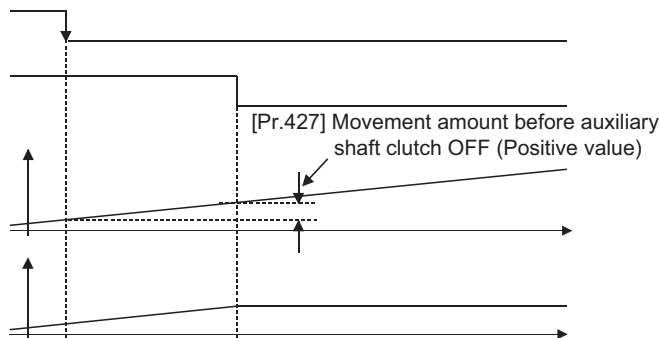

[Pr.428] Auxiliary shaft clutch smoothing method

Set the smoothing method for clutch ON/OFF.

Refer to the following.

Page 117 Smoothing method for clutch

Setting value	Details
0: Direct	No smoothing.
1: Time constant method (Exponent)	Smoothing with an exponential curve based on the time constant setting.
2: Time constant method (Linear)	Smoothing with linear acceleration/deceleration based on the time constant setting.
3: Slippage method (Exponent)	Smoothing with an exponential curve based on the slippage amount setting.
4: Slippage method (Linear)	Smoothing with linear acceleration/deceleration based on the slippage amount setting.
5: Slippage method (Linear: Input value follow up)	Smoothing with linear acceleration/deceleration based on the slippage amount setting (input value follow up).

[Pr.429] Auxiliary shaft clutch smoothing time constant

Set a time constant when the time constant method is set in "[Pr.428] Auxiliary shaft clutch smoothing method".

The time constant setting applies for clutch ON/OFF.

[Pr.430] Slippage amount at auxiliary shaft clutch ON

Set the slippage amount at clutch ON when the slippage method is set in "[Pr.428] Auxiliary shaft clutch smoothing method".

The slippage amount is set in units based on the current value selected in "[Pr.423] Auxiliary shaft clutch reference address setting".

If the set amount is negative, the slippage amount at clutch ON is controlled as 0 (direct).

[Pr.431] Slippage amount at auxiliary shaft clutch OFF

Set the slippage amount at clutch OFF when the slippage method is set in "[Pr.428] Auxiliary shaft clutch smoothing method".

The slippage amount is set in units based on the current value selected in "[Pr.423] Auxiliary shaft clutch reference address setting".

If the set amount is negative, the slippage amount at clutch OFF is controlled as 0 (direct).

Auxiliary shaft clutch control data

n: Axis No. - 1 (n: Axis No. - 17 for axis 17 to axis 32)

Setting item	Setting details	Setting value	Default value	Buffer memory address	
				Axis 1 to axis 16	Axis 17 to axis 32
[Cd.403] Auxiliary shaft clutch command	<ul style="list-style-type: none"> Set the clutch command ON/OFF. Fetch cycle: Operation cycle	■Set in decimal. 0: Auxiliary shaft clutch command OFF 1: Auxiliary shaft clutch command ON	0	44083+20n	1044083+20n
[Cd.404] Auxiliary shaft clutch control invalid command	<ul style="list-style-type: none"> Set "1" to disable the clutch control temporarily. Fetch cycle: Operation cycle	■Set in decimal. 0: Auxiliary shaft clutch control valid 1: Auxiliary shaft clutch control invalid	0	44084+20n	1044084+20n
[Cd.405] Auxiliary shaft clutch forced OFF command	<ul style="list-style-type: none"> Set "1" to force the clutch OFF. Fetch cycle: Operation cycle	■Set in decimal. 0: Auxiliary shaft clutch normal control 1: Auxiliary shaft clutch forced OFF	0	44085+20n	1044085+20n

[Cd.403] Auxiliary shaft clutch command

Set ON/OFF for the auxiliary shaft clutch command. This command is used when the clutch ON control mode is "1: Clutch command ON/OFF", "2: Clutch command leading edge" or "3: Clutch command trailing edge" and the clutch OFF control mode is "2: Clutch command leading edge" or "3: Clutch command trailing edge".

Status is considered as clutch command OFF just before starting synchronous control. If synchronous control is started while the clutch command is ON, the condition is established just after starting synchronous control, by setting "2: Clutch command leading edge". The condition is not established just after starting, by setting "3: Clutch command trailing edge".

[Cd.404] Auxiliary shaft clutch control invalid command

The auxiliary shaft clutch control is invalid if "1" is set. The previous clutch ON/OFF status remains before clutch control becomes invalid.

Clutch control will not become invalid during the movement before clutch ON and clutch OFF. Instead, clutch control will become invalid after the movement is completed.

[Cd.405] Auxiliary shaft clutch forced OFF command

Set "1" to force the clutch OFF. The output value from the clutch becomes 0 immediately, even during clutch smoothing. The slippage (accumulative) amount is set to 0 if smoothing with a slippage method.

Reset to "0" to restart the clutch control from the clutch OFF status after using the clutch forced OFF command.

4.3 Clutch

Overview of clutch

The clutch is used to transmit/disengage command pulses from the main/auxiliary shaft input side to the output axis module through turning the clutch ON/OFF, which controls the operation/stop of the servomotor.

A clutch can be configured for the main and auxiliary shafts.

Control method for clutch

Set the ON and OFF control methods separately in "[Pr.405] Main shaft clutch control setting" and "[Pr.422] Auxiliary shaft clutch control setting".

The clutch control setting can be changed during synchronous control, however, the setting "No clutch" (Direct coupled operation) cannot be selected during synchronous control after already selecting another setting.

Item	Setting item		Setting details/Setting value
	Main shaft clutch	Auxiliary shaft clutch	
Clutch control setting	[Pr.405] Main shaft clutch control setting	[Pr.422] Auxiliary shaft clutch control setting	<ul style="list-style-type: none"> • Set the control method for the clutch. ■ Set in hexadecimal. <div style="margin-left: 20px;"> <p>H</p> <ul style="list-style-type: none"> → ON control mode <ul style="list-style-type: none"> 0: No clutch 1: Clutch command ON/OFF 2: Clutch command leading edge 3: Clutch command trailing edge 4: Address mode 5: High speed input request [RD77MS] 6: Main/auxiliary shaft clutch control request ON/OFF [RD77GF] 7: Main/auxiliary shaft clutch control request leading edge [RD77GF] 8: Main/auxiliary shaft clutch control request trailing edge [RD77GF] → OFF control mode <ul style="list-style-type: none"> 0: OFF control invalid 1: One-shot OFF 2: Clutch command leading edge 3: Clutch command trailing edge 4: Address mode 5: High speed input request [RD77MS] 7: Main/auxiliary shaft clutch control request leading edge [RD77GF] 8: Main/auxiliary shaft clutch control request trailing edge [RD77GF] → High speed input request signal <ul style="list-style-type: none"> 0 to F: High speed input request signal from axis 1 to axis 16^{*1} [RD77MS] </div>

*1 The range from axis 1 to 2 is valid in the 2-axis module, from axis 1 to 4 is valid in the 4-axis module, from axis 1 to 8 is valid in the 8-axis module, and from 1 to 16 is valid in the 16-axis module.

When the clutch ON condition and the clutch OFF condition are completed simultaneously within one operation cycle, both clutch ON and OFF processing are executed within one operation cycle. Therefore, the clutch is from OFF to ON and again to OFF at the clutch OFF status, and it is from ON to OFF and again to ON at the clutch ON status.

The following shows the operations for the clutch ON/OFF by the setting of the ON control mode and the OFF control mode.

ON control mode

■No clutch (Direct coupled operation)

Execute direct coupled operation without clutch control.

Point

Other clutch parameters are not applicable during direct coupled operation by setting "0: No clutch". "Clutch forced OFF command" and the change of the clutch control setting are ignored during direct coupled operation.

■Clutch command ON/OFF

The clutch is turned ON/OFF by the operation of clutch command ON/OFF.

(Setting in the OFF control mode are not applicable in this mode.)

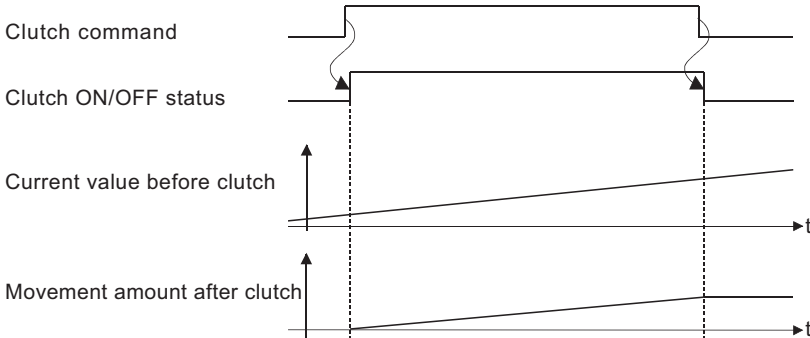

Item	Main shaft clutch	Auxiliary shaft clutch
Clutch command	[Cd.400] Main shaft clutch command	[Cd.403] Auxiliary shaft clutch command
Clutch ON/OFF status	[Md.420] Main shaft clutch ON/OFF status	[Md.423] Auxiliary shaft clutch ON/OFF status

■Clutch command leading edge

The clutch is turned ON when the clutch command passes the leading edge (from OFF to ON).

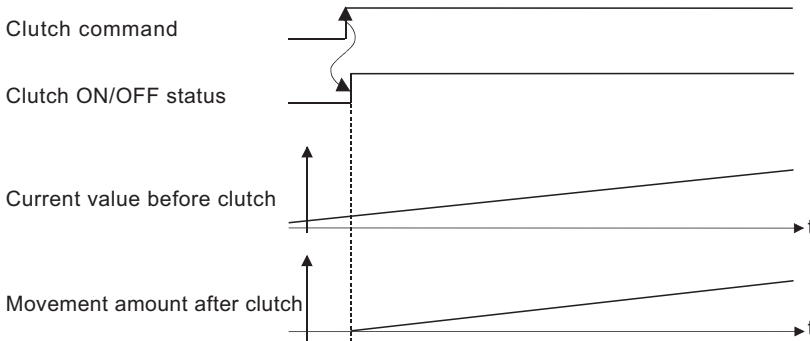

■Clutch command trailing edge

The clutch is turned ON when the clutch command passes the trailing edge (from ON to OFF).

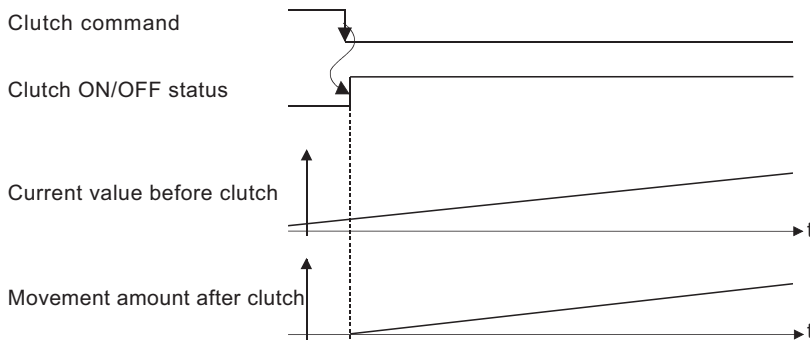

■Address mode

The clutch is turned ON when the reference address reaches "Clutch ON address".

The movement amount after passing through the ON address is calculated as the output movement amount of the clutch based on the reference address passing through, thereby controlling the clutch with an accurate movement amount.

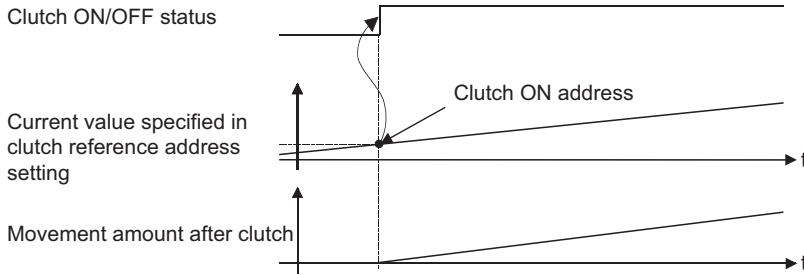

Item	Main shaft clutch	Auxiliary shaft clutch
Reference address	The current value specified in "[Pr.406] Main shaft clutch reference address setting" ("[Md.400] Current value after composite main shaft gear" or "[Md.401] Current value per cycle after main shaft gear")	The current value specified in "[Pr.423] Auxiliary shaft clutch reference address setting" (Auxiliary shaft current value (servo input axis current value/synchronous encoder axis current value) or "[Md.402] Current value per cycle after auxiliary shaft gear")
Clutch ON address	[Pr.407] Main shaft clutch ON address	[Pr.424] Auxiliary shaft clutch ON address
Clutch ON/OFF status	[Md.420] Main shaft clutch ON/OFF status	[Md.423] Auxiliary shaft clutch ON/OFF status

■High speed input request [RD77MS]

The clutch is turned ON when the high speed input request [DI] turns ON.

The following actions are required when using the high speed input request.

- Set the signal No. for the "High speed input request signal" clutch control setting.
- Set the external command signal used in "[Pr.95] External command signal selection", "4: High speed input request" in "[Pr.42] External command function selection" and "1: Validates an external command" in "[Cd.8] External command valid" for the applicable axis.

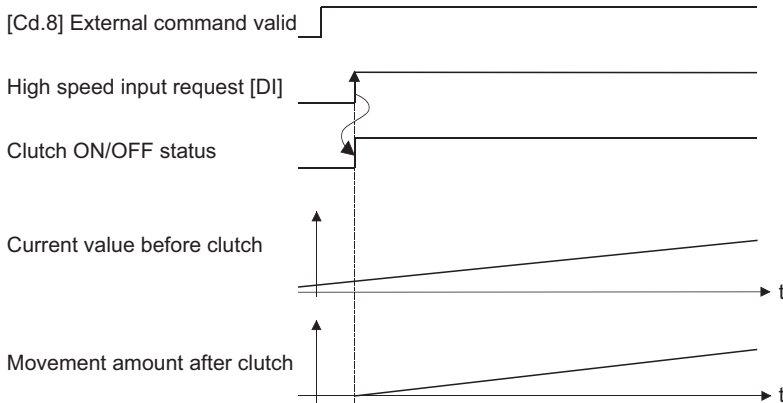

■Main shaft clutch control request ON/OFF [RD77GF]

The clutch is turned ON/OFF by ON/OFF operation of the link device assigned to the "Main shaft clutch control request".
(Setting in the OFF control mode are not applicable in this mode.)

The clutch is turned OFF when a communication error occurs in the station of the assigned link device.

The following actions are required when using the main shaft clutch control request.

- Assign the link device to the main shaft clutch control request with the link device external signal assignment function.
- Set "1: Validates an external command" in "[Cd.8] External command valid".

Item	Main shaft clutch	Auxiliary shaft clutch
Clutch command	Link device assigned to the main shaft clutch control request with the link device external signal assignment function	Link device assigned to the auxiliary shaft clutch control request with the link device external signal assignment function
Clutch ON/OFF status	[Md.420] Main shaft clutch ON/OFF status	[Md.423] Auxiliary shaft clutch ON/OFF status

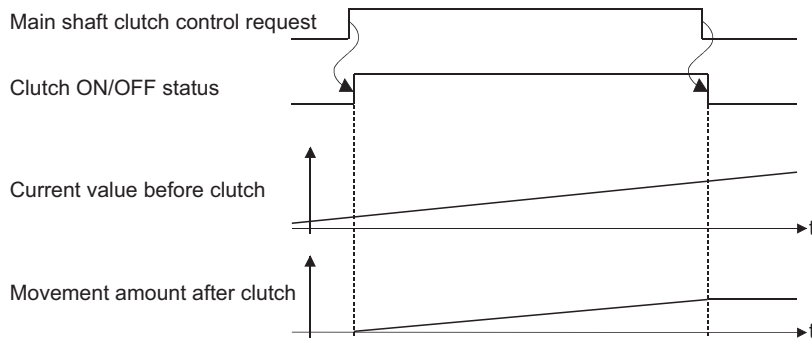

■Main shaft clutch control request leading edge [RD77GF]

The clutch is turned ON when the link device assigned to the "Main shaft clutch control request" passes the leading edge (from OFF to ON).

The clutch is turned OFF when a communication error occurs in the station of the assigned link device.

The following actions are required when using the main shaft clutch control request.

- Assign the link device to the main shaft clutch control request with the link device external signal assignment function.
- Set "1: Validates an external command" in "[Cd.8] External command valid".

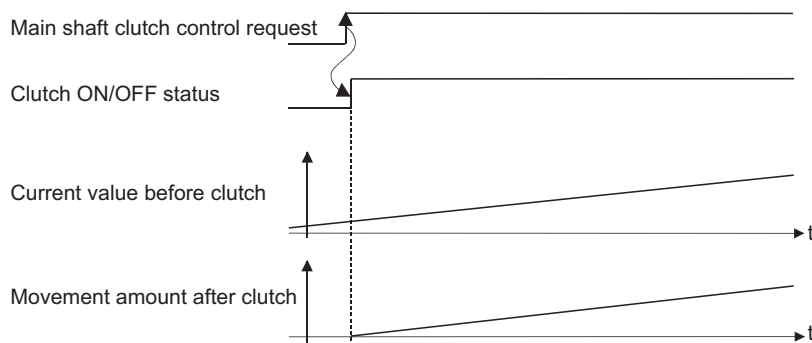

■Main shaft clutch control request trailing edge [RD77GF]

The clutch is turned ON when the link device assigned to the "Main shaft clutch control request" passes the trailing edge (from ON to OFF).

The clutch is turned OFF when a communication error occurs in the station of the assigned link device.

The following actions are required when using the main shaft clutch control request.

- Assign the link device to the main shaft clutch control request with the link device external signal assignment function.
- Set "1: Validates an external command" in "[Cd.8] External command valid".

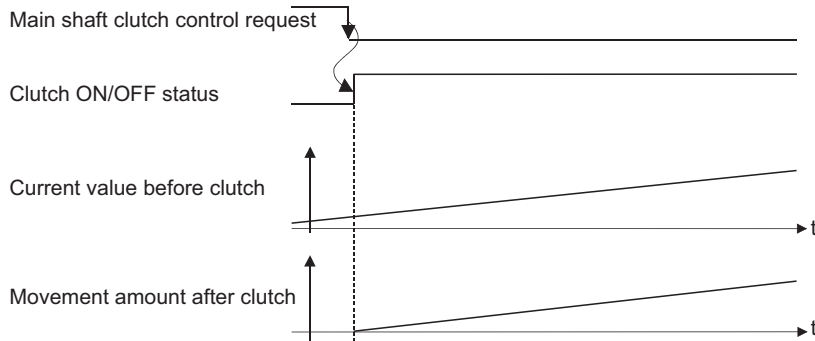

OFF control mode

■OFF control invalid

Clutch OFF control is not used. This setting is applicable only for execution with clutch ON control.

■One-shot OFF

The clutch is turned OFF after moving the distance "Movement amount before clutch OFF" (One-shot operation) after the clutch command turn ON.

If "Movement amount before clutch OFF" is 0, "Clutch ON/OFF status" does not turn ON in order to turn back OFF immediately.

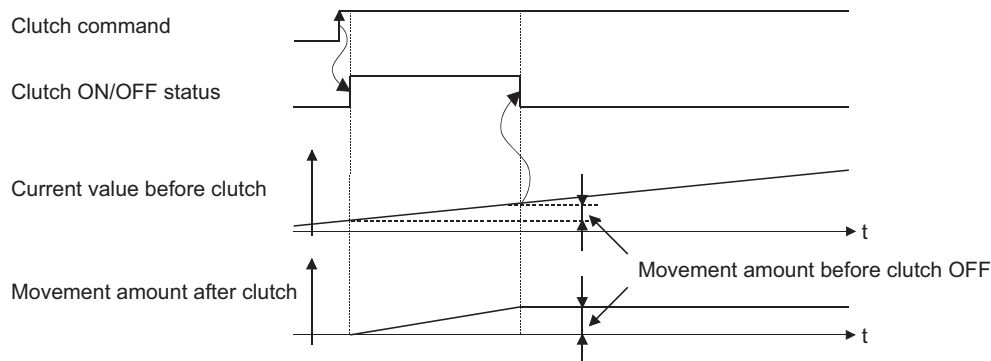

Item	Main shaft clutch	Auxiliary shaft clutch
Clutch command	[Cd.400] Main shaft clutch command	[Cd.403] Auxiliary shaft clutch command
Clutch ON/OFF status	[Md.420] Main shaft clutch ON/OFF status	[Md.423] Auxiliary shaft clutch ON/OFF status
Movement amount before clutch OFF	[Pr.410] Movement amount before main shaft clutch OFF	[Pr.427] Movement amount before auxiliary shaft clutch OFF

■Clutch command leading edge

The clutch is turned OFF when the clutch command passes the leading edge (from OFF to ON).

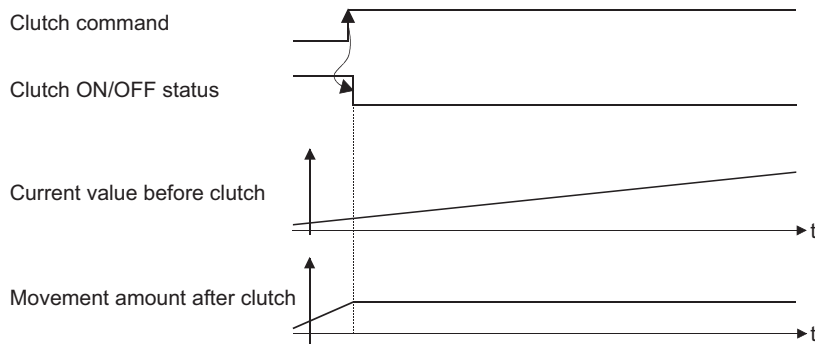

■Clutch command trailing edge

The clutch is turned OFF when the clutch command passes the trailing edge (from ON to OFF).

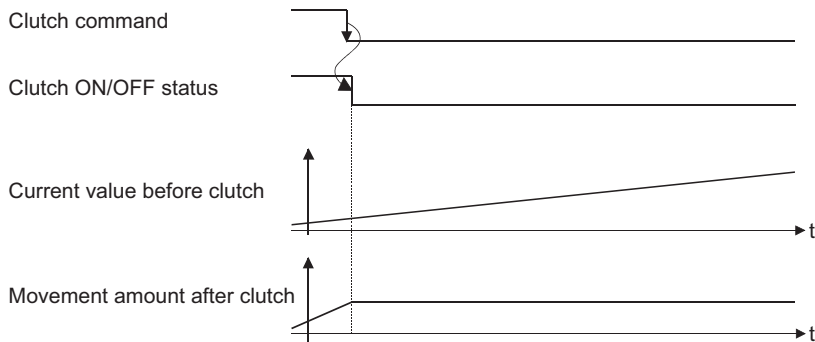

■Address mode

The clutch is turned OFF when the reference address reaches "Clutch OFF address".

The movement amount before passing through the OFF address is calculated as the output movement amount of the clutch based on the reference address passing through, thereby controlling the clutch with an accurate movement amount.

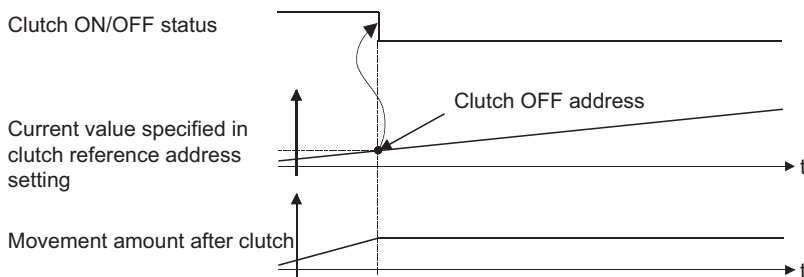

Item	Main shaft clutch	Auxiliary shaft clutch
Reference address	The current value specified in "[Pr.406] Main shaft clutch reference address setting" ("[Md.400] Current value after composite main shaft gear" or "[Md.401] Current value per cycle after main shaft gear")	The current value specified in "[Pr.423] Auxiliary shaft clutch reference address setting" (Auxiliary shaft current value (servo input axis current value/synchronous encoder axis current value) or "[Md.402] Current value per cycle after auxiliary shaft gear")
Clutch OFF address	[Pr.409] Main shaft clutch OFF address	[Pr.426] Auxiliary shaft clutch OFF address
Clutch ON/OFF status	[Md.420] Main shaft clutch ON/OFF status	[Md.423] Auxiliary shaft clutch ON/OFF status

■High speed input request [RD77MS]

The clutch is turned OFF when the high speed input request [DI] turns ON.

The following actions are required when using the high speed input request.

- Set the signal No. for the "High speed input request signal" clutch control setting.
- Set the external command signal used in "[Pr.95] External command signal selection", "4: High speed input request" in "[Pr.42] External command function selection" and "1: Validates an external command" in "[Cd.8] External command valid" for the applicable axis.

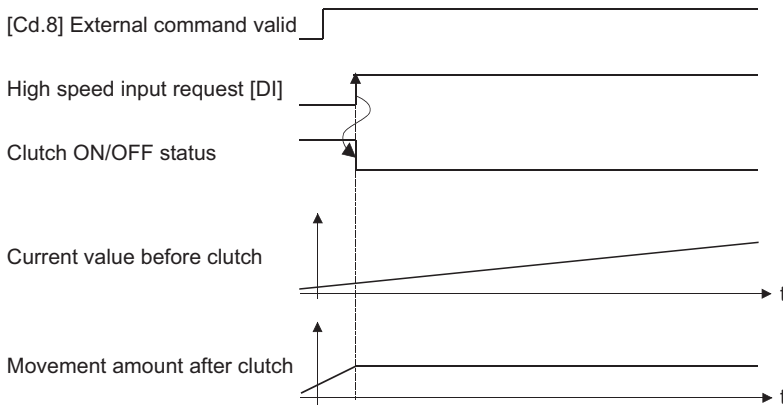

■Auxiliary shaft clutch control request leading edge [RD77GF]

The clutch is turned ON when the link device assigned to the "Auxiliary shaft clutch control request" passes the leading edge (from OFF to ON).

The clutch is turned OFF when a communication error occurs in the station of the assigned link device.

The following actions are required when using the auxiliary shaft clutch control request.

- Assign the link device to the auxiliary shaft clutch control request with the link device external signal assignment function.
- Set "1: Validates an external command" in "[Cd.8] External command valid".

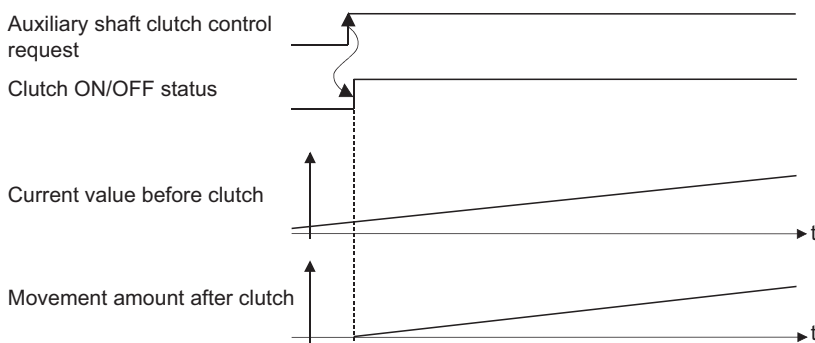

■Auxiliary shaft clutch control request trailing edge [RD77GF]

The clutch is turned ON when the link device assigned to the "Auxiliary shaft clutch control request" passes the trailing edge (from ON to OFF).

The clutch is turned OFF when a communication error occurs in the station of the assigned link device.

The following actions are required when using the auxiliary shaft clutch control request.

- Assign the link device to the auxiliary shaft clutch control request with the link device external signal assignment function.
- Set "1: Validates an external command" in "[Cd.8] External command valid".

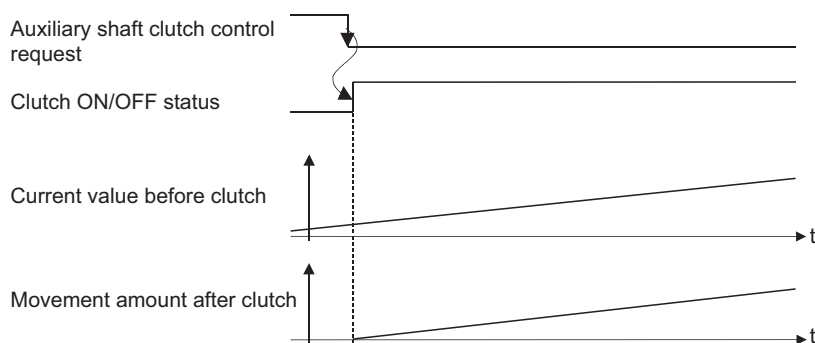

Smoothing method for clutch

Set the clutch smoothing method in "[Pr.411] Main shaft clutch smoothing method" and "[Pr.428] Auxiliary shaft clutch smoothing method".

The 2 types of clutch smoothing include the following.

- Time constant method smoothing
- Slippage method smoothing

When not using clutch smoothing, set "0: Direct" in the clutch smoothing method.

Item	Setting item		Setting details/Setting value
	Main shaft clutch	Auxiliary shaft clutch	
Clutch smoothing method	[Pr.411] Main shaft clutch smoothing method	[Pr.428] Auxiliary shaft clutch smoothing method	<ul style="list-style-type: none"> • Set the clutch smoothing method. ■Set in decimal. 0: Direct 1: Time constant method (Exponent) 2: Time constant method (Linear) 3: Slippage method (Exponent) 4: Slippage method (Linear) 5: Slippage method (Linear: Input value follow up)

The operation of each smoothing method is shown below.

Time constant method smoothing

Smoothing is processed with the time constant setting value in the smoothing time constant at clutch ON/OFF. After clutch ON smoothing is complete, smoothing is processed with the time constant setting value when the speed of the input values changes.

The movement amount between the clutch turning ON and OFF is not changed with smoothing.

Movement amount after clutch smoothing = Movement amount before clutch smoothing

Item	Setting item		Setting details	Setting value
	Main shaft clutch	Auxiliary shaft clutch		
Clutch smoothing time constant	[Pr.412] Main shaft clutch smoothing time constant	[Pr.429] Auxiliary shaft clutch smoothing time constant	• For smoothing with a time constant method, set the smoothing time constant.	■Set in decimal. 0 to 5000 [ms]

■Time constant method exponential curve smoothing

Set "1: Time constant method (Exponential)" in the clutch smoothing method.

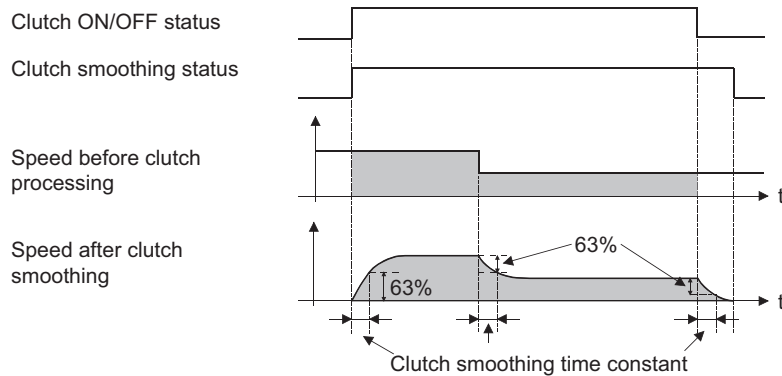

Item	Main shaft clutch	Auxiliary shaft clutch
Clutch ON/OFF status	[Md.420] Main shaft clutch ON/OFF status	[Md.423] Auxiliary shaft clutch ON/OFF status
Clutch smoothing status	[Md.421] Main shaft clutch smoothing status	[Md.424] Auxiliary shaft clutch smoothing status

Time constant method linear acceleration/deceleration smoothing

Set "2: Time constant method (Linear)" in the clutch smoothing method.

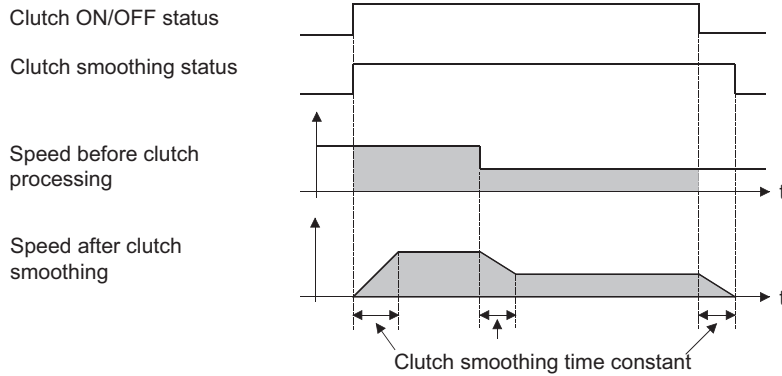

Slippage method smoothing

Smoothing is processed with the value in slippage at clutch ON when the clutch turns ON, and with slippage at clutch OFF when the clutch turns OFF.

Smoothing is also processed with the slippage amount setting when the input speed to the clutch changes, therefore, positioning control at clutch ON/OFF is not affected by speed changes.

Processing proceeds with direct operation after completing clutch ON smoothing.

The movement amount between the clutch turning ON and OFF is as follows after clutch smoothing.

Movement amount after clutch smoothing = Movement amount before clutch smoothing + (Slippage amount at OFF - Slippage amount at ON)

Item	Setting item		Setting details	Setting value
	Main shaft clutch	Auxiliary shaft clutch		
Slippage amount at clutch ON	[Pr.413] Slippage amount at main shaft clutch ON	[Pr.430] Slippage amount at auxiliary shaft clutch ON	For smoothing with a slippage method, set the slippage amount at clutch ON.	<ul style="list-style-type: none"> Set in decimal. 0 to 2147483647 [Main input axis position units^{*1}/ auxiliary shaft position units^{*2} or cam axis cycle units^{*3}]
Slippage amount at clutch OFF	[Pr.414] Slippage amount at main shaft clutch OFF	[Pr.431] Slippage amount at auxiliary shaft clutch OFF	For smoothing with a slippage method, set the slippage amount at clutch OFF.	

*1 Main input axis position units (Page 28 INPUT AXIS MODULE)

*2 Auxiliary shaft position units (Page 28 INPUT AXIS MODULE)

*3 Cam axis cycle units (Page 126 Units for the output axis)

Slippage method exponential curve smoothing

Set "3: Slippage (Exponential)" in the clutch smoothing method.

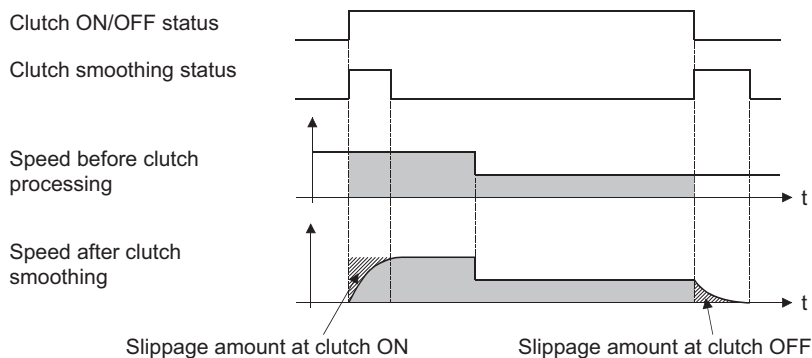

Item	Main shaft clutch	Auxiliary shaft clutch
Clutch ON/OFF status	[Md.420] Main shaft clutch ON/OFF status	[Md.423] Auxiliary shaft clutch ON/OFF status
Clutch smoothing status	[Md.421] Main shaft clutch smoothing status	[Md.424] Auxiliary shaft clutch smoothing status

Slippage method linear acceleration/deceleration smoothing

Set "4: Slippage method (Linear)" or "5: Slippage method (Linear: Input value follow up)" in the clutch smoothing method. The differences between "4: Slippage method (Linear)" and "5: Slippage method (Linear: Input value follow up)" are shown below.

Input speed during smoothing	Smoothing method	
	4: Slippage method (Linear)	5: Slippage method (Linear: Input value follow up)
When the speed is fixed	No differences	
When the speed is changed continuously and slightly	Smoothing section is changed.	Smoothing section is fixed.
When the speed is changed largely	The output speed is changed slightly. (The average speed might be faster than the speed before starting smoothing.)	The output speed is changed depending on the input speed. (When the input speed is decelerated and accelerated again, the speed might be accelerated rapidly.)

- When the input speed to the clutch is fixed

The operations of "4: Slippage method (Linear)" and "5: Slippage method (Linear: Input value follow up)" are same.

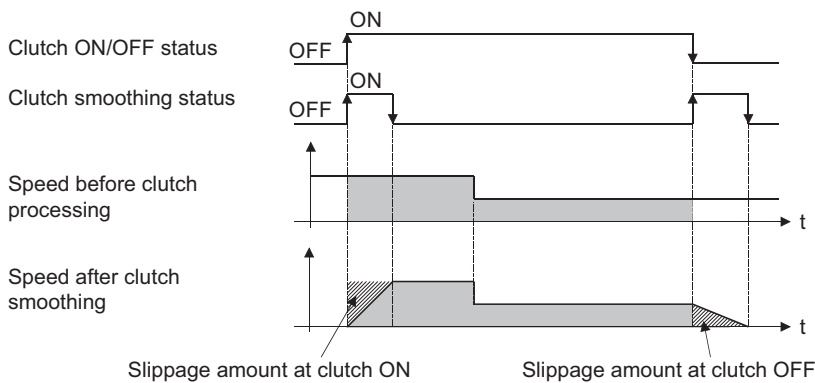

- When the input speed to the clutch is changed continuously and slightly

["4: Slippage method (Linear)" is set.]

The clutch smoothing status ON section is changed.

When the clutch smoothing status ON section is extended

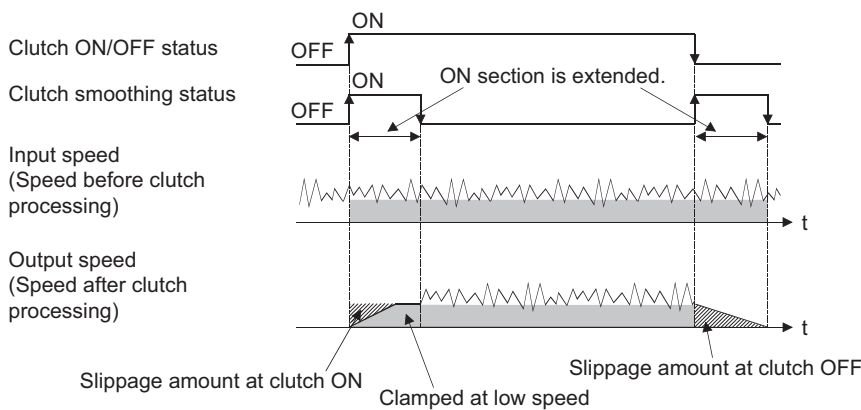

When the clutch smoothing status ON section is shortened

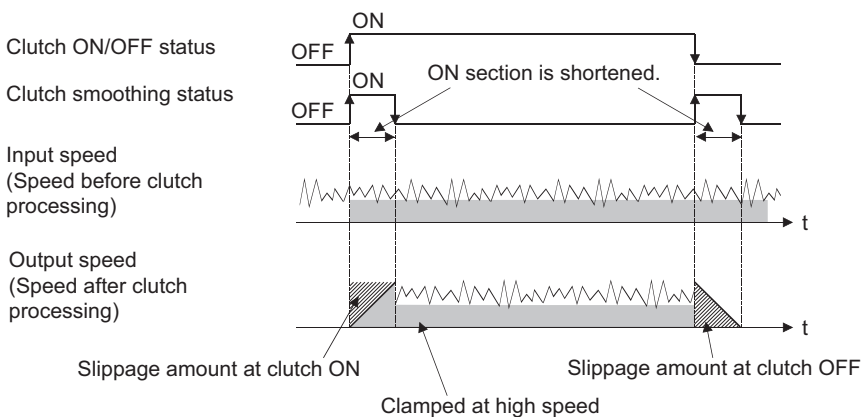

["5: Slippage method (Linear: Input value follow up)" is set.]

The clutch smoothing status ON section is fixed.

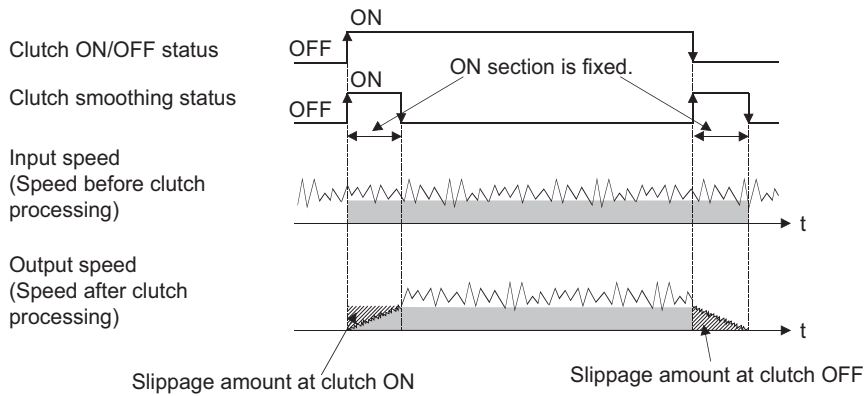

- When the input speed is changed largely during smoothing

["4: Slippage method (Linear)" is set.]

The output speed is changed slightly compared to the change of the input speed.

(The average speed might be faster than the speed before starting smoothing.)

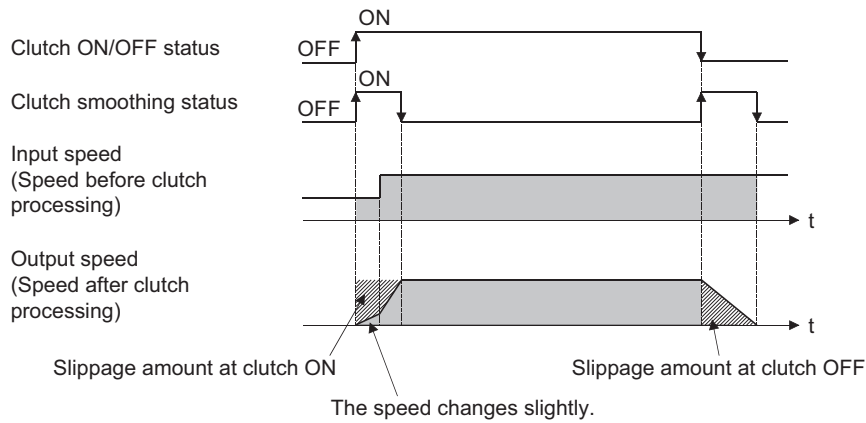

["5: Slippage method (Linear: Input value follow up)" is set.]

The output speed is changed depending on the input speed.

(When the input speed is decelerated and accelerated again, the speed might be accelerated rapidly.)

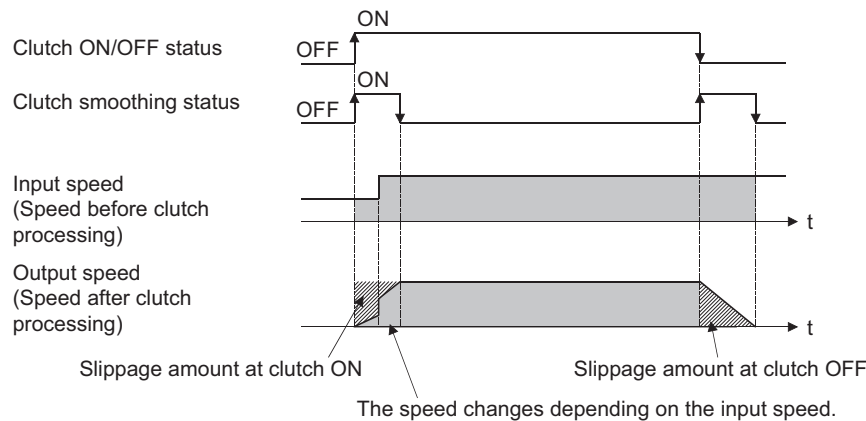

■ Operation at input speed deceleration during slippage method smoothing

When the speed before clutch processing decreases, the speed after clutch smoothing is controlled without exceeding the speed before clutch processing.

If slippage amount remains when the speed before clutch processing becomes 0, the smoothing process will be continued. Then, the clutch smoothing process will be executed with the remaining slippage amount when the speed before clutch processing gets faster than the speed after clutch smoothing.

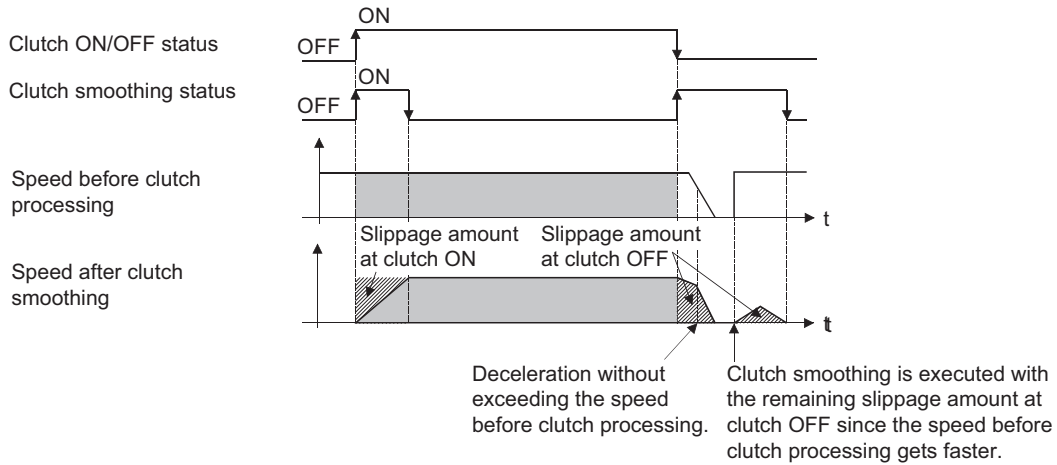

Use example of clutch

The following machine shows an example using clutch control for a flying shear cutting system that synchronizes off a start signal from a sensor input.

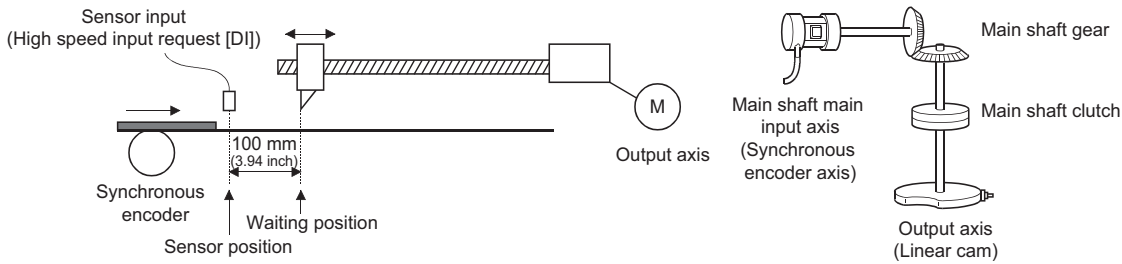

Main shaft clutch setting item		Setting value
[Pr.405] Main shaft clutch control setting	ON control mode	5: High speed input request [RD77MS]
	OFF control mode	1: One-shot OFF
	High speed input request signal [RD77MS]	(Specify the high speed input request signal No., used for sensor input.)
[Pr.406] Main shaft clutch reference address setting		0: Current value after composite main shaft gear
[Pr.408] Movement amount before main shaft clutch ON		0 mm
[Pr.410] Movement amount before main shaft clutch OFF		380 mm (14.96 inch)
[Pr.411] Main shaft clutch smoothing method		4: Slippage method (Linear)
[Pr.413] Slippage amount at main shaft clutch ON		100 mm (3.94 inch) (Distance between the sensor and the waiting position)
[Pr.414] Slippage amount at main shaft clutch OFF		20 mm (0.79 inch)

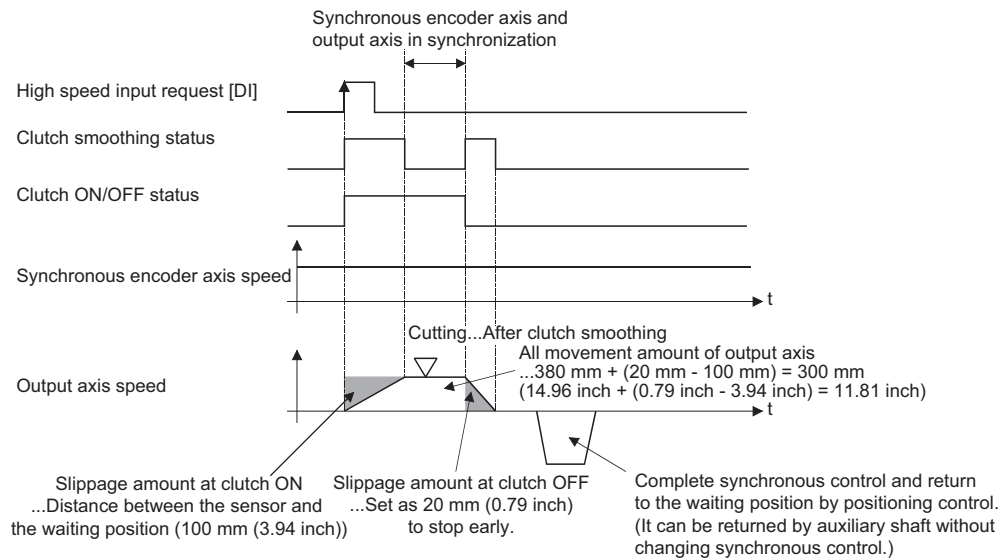

4.4 Speed Change Gear Module

Overview of speed change gear module

A speed change gear module is used to change the input speed from the main shaft/auxiliary shaft/composite auxiliary shaft gear during operation. When not using a speed change gear module, set "0: No speed change gear" in "[Pr.434] Speed change gear".

With speed change from a speed change gear module, operation is executed with linear acceleration/deceleration based on the setting for the speed change gear smoothing time constant.

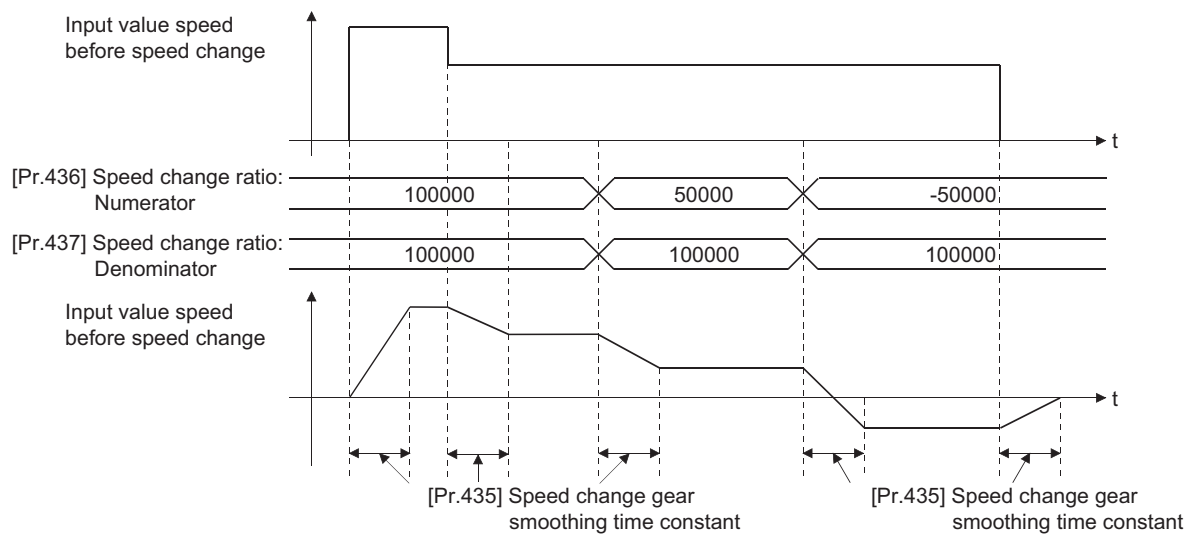
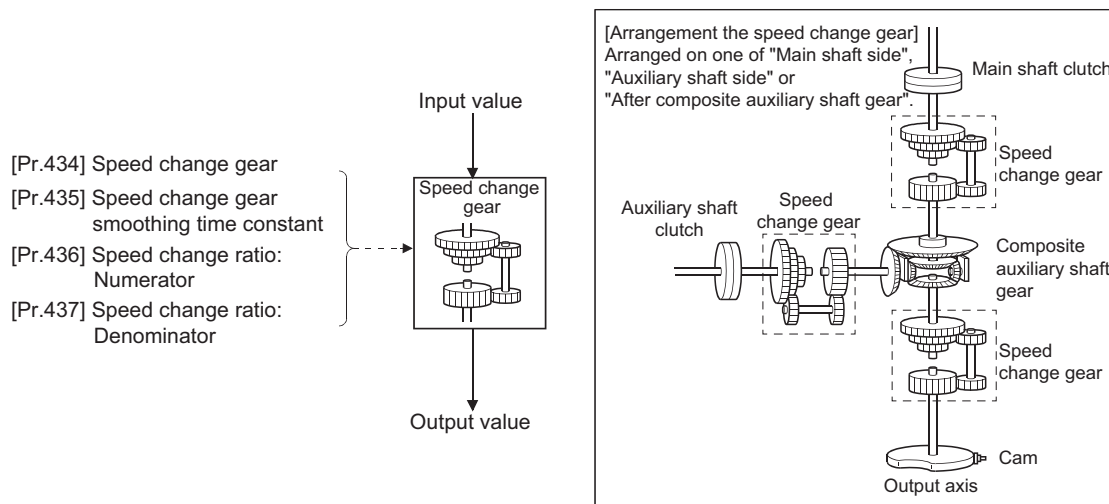

Speed change gear parameters

n: Axis No. - 1 (n: Axis No. - 17 for axis 17 to axis 32)

Setting item	Setting details	Setting value	Default value	Buffer memory address	
				Axis 1 to axis 16	Axis 17 to axis 32
[Pr.434] Speed change gear	<ul style="list-style-type: none"> Set the arrangement for the speed change gear. <u>Fetch cycle: At start of synchronous control</u>	<ul style="list-style-type: none"> Set in decimal. 0: No speed change gear 1: Main shaft side 2: Auxiliary shaft side 3: After composite auxiliary shaft gear 	0	36460+200n	1036460+200n
[Pr.435] Speed change gear smoothing time constant	<ul style="list-style-type: none"> Set the smoothing time constant for the speed change gear. <u>Fetch cycle: At start of synchronous control</u>	<ul style="list-style-type: none"> Set in decimal. 0 to 5000 [ms] 	0	36461+200n	1036461+200n
[Pr.436] Speed change ratio: Numerator	<ul style="list-style-type: none"> Set the numerator for the speed change ratio. <u>Fetch cycle: Operation cycle</u>	<ul style="list-style-type: none"> Set in decimal. -2147483648 to 2147483647 	1	36462+200n 36463+200n	1036462+200n 1036463+200n
[Pr.437] Speed change ratio: Denominator	<ul style="list-style-type: none"> Set the denominator for the speed change ratio. <u>Fetch cycle: Operation cycle</u>	<ul style="list-style-type: none"> Set in decimal. 1 to 2147483647 	1	36464+200n 36465+200n	1036464+200n 1036465+200n

[Pr.434] Speed change gear

Set the arrangement for the speed change gear.

Setting value	Details
0: No speed change gear	Speed change is not processed, and the input value is transmitted as is.
1: Main shaft side	Speed change is processed for input value after main shaft clutch based on the speed change ratio settings.
2: Auxiliary shaft side	Speed change is processed for input value after auxiliary shaft clutch based on the speed change ratio settings.
3: After composite auxiliary shaft gear	Speed change is processed for input value after composite auxiliary shaft gear based on the speed change ratio settings.

[Pr.435] Speed change gear smoothing time constant

Set the averaging time to execute a smoothing process for the speed change for the speed change gear.

The input response is delayed depending on the time set in the speed change gear smoothing time constant.

Speed is changed directly when "0" is set.

[Pr.436] Speed change ratio: Numerator, [Pr.437] Speed change ratio: Denominator

Set the numerator and the denominator for the speed change ratio.

"[Pr.436] Speed change ratio: Numerator" and "[Pr.437] Speed change ratio: Denominator" can be changed during synchronous control.

Input values for speed change are processed as follows.

$$\text{Input value after change} = \text{Input value before change} \times \frac{\text{[Pr.436] Speed change ratio: Numerator}}{\text{[Pr.437] Speed change ratio: Denominator}}$$

The input speed can be reversed by setting a negative value in "[Pr.436] Speed change ratio: Numerator".

"[Pr.437] Speed change ratio: Denominator" is set within the range from 1 to 2147483647.

4.5 Output Axis Module

Overview of output axis module

For the output axis module, the cam axis current value per cycle is calculated based on the input value (the output value from a speed change gear), and is converted based on the set cam data. The feed current value which is a command is output to the servo amplifier.

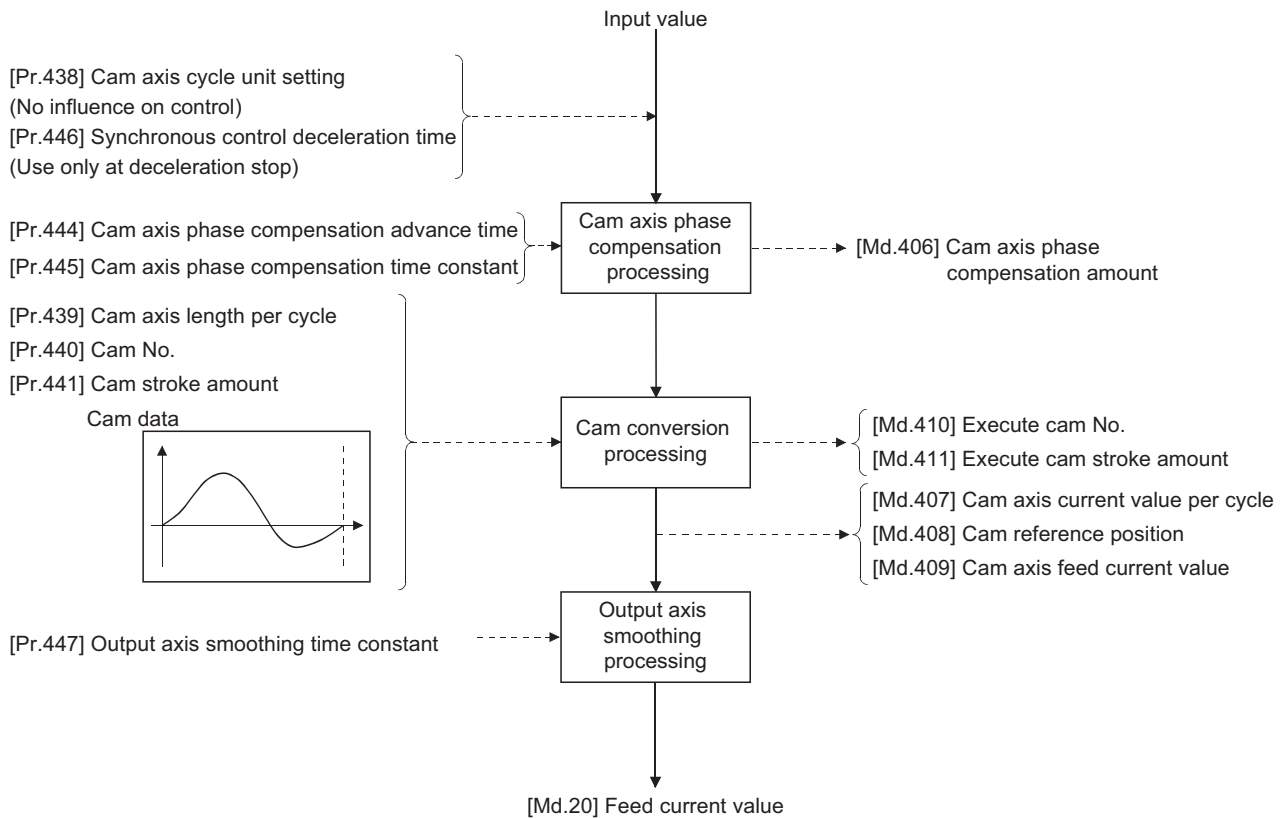

Units for the output axis

The position units for the output axis are shown below based on the setting "[Pr.1] Unit setting".

Setting value of "[Pr.1] Unit setting"	Output axis position unit	Range
0: mm	$\times 10^{-4}$ mm ($\times 10^{-1}$ μ m)	-214748.3648 to 214748.3647 [mm] (-214748364.8 to 214748364.7 [μ m])
1: inch	$\times 10^{-5}$ inch	-21474.83648 to 21474.83647 [inch]
2: degree	$\times 10^{-5}$ degree	-21474.83648 to 21474.83647 [degree]
3: pulse	pulse	-2147483648 to 2147483647 [pulse]

Cam axis cycle units are shown below based on the setting "[Pr.438] Cam axis cycle unit setting".

Setting value of "[Pr.438] Cam axis cycle unit setting"			Cam axis cycle unit	Range
Unit setting selection	Control unit	Number of decimal places		
0: Use units of main input axis	—	—	Servo input axis position unit (☞ Page 29 Servo input axis position units) Synchronous encoder axis position unit (☞ Page 36 Synchronous encoder axis position units)	
1: Use units of this setting	0: mm	0	mm	-2147483648 to 2147483647 [mm]
		∴	∴	∴
		9	$\times 10^{-9}$ mm	-2.147483648 to 2.147483647 [mm]
	1: inch	0	inch	-2147483648 to 2147483647 [inch]
		∴	∴	∴
		9	$\times 10^{-9}$ inch	-2.147483648 to 2.147483647 [inch]
	2: degree	0	degree	-2147483648 to 2147483647 [degree]
		∴	∴	∴
		9	$\times 10^{-9}$ degree	-2.147483648 to 2.147483647 [degree]
	3: pulse	0	pulse	-2147483648 to 2147483647 [pulse]
		∴	∴	∴
		9	$\times 10^{-9}$ pulse	-2.147483648 to 2.147483647 [pulse]

Output axis parameters

n: Axis No. - 1 (n: Axis No. - 17 for axis 17 to axis 32)

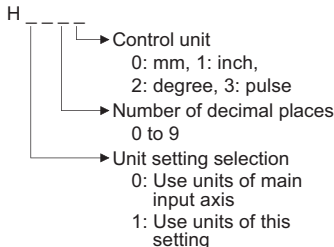
Setting item	Setting details	Setting value	Default value	Buffer memory address	
				Axis 1 to axis 16	Axis 17 to axis 32
[Pr.438] Cam axis cycle unit setting	<ul style="list-style-type: none"> Set the units for the cam axis length per cycle. There is no influence on the control for the parameter for monitor display. <u>Fetch cycle: At start of synchronous control</u>	<p>■Set in hexadecimal.</p> 	0000H	36470+200n	1036470+200n
[Pr.439] Cam axis length per cycle	<ul style="list-style-type: none"> Set the required input amount with the cam per cycle. <u>Fetch cycle: At start of synchronous control.</u> <u>At passing through the 0th point of cam data</u>	<p>■Set in decimal.</p> 1 to 2147483647 [Cam axis cycle units ^{*1}]	4194304	36472+200n 36473+200n	1036472+200n 1036473+200n
[Pr.440] Cam No.	<ul style="list-style-type: none"> Set the cam No. <u>Fetch cycle: At start of synchronous control.</u> <u>At passing through the 0th point of cam data</u>	<p>■Set in decimal.</p> 0: Linear cam (Preset) 1 to 256: User created cam [RD77MS] 1 to 1024: User created cam [RD77GF]	0	36474+200n	1036474+200n
[Pr.441] Cam stroke amount	<ul style="list-style-type: none"> Set the cam stroke amount corresponding to the stroke ratio 100% for cam with stroke ratio data format. This is ignored for cams using the coordinate data format. <u>Fetch cycle: At start of synchronous control.</u> <u>At passing through the 0th point of cam data</u>	<p>■Set in decimal.</p> -2147483648 to 2147483647 [Output axis position units ^{*2}]	4194304	36476+200n 36477+200n	1036476+200n 1036477+200n
[Pr.442] Cam axis length per cycle change setting	<ul style="list-style-type: none"> Set to change the "[Pr.439] Cam axis length per cycle" during synchronous control. <u>Fetch cycle: At start of synchronous control</u>	<p>■Set in decimal.</p> 0: Invalid 1: Valid	0	36471+200n	1036471+200n
[Pr.444] Cam axis phase compensation advance time	<ul style="list-style-type: none"> Set the time to advance or delay the phase of the cam axis. <u>Fetch cycle: Operation cycle</u>	<p>■Set in decimal.</p> -2147483648 to 2147483647 [μs]	0	36482+200n 36483+200n	1036482+200n 1036483+200n
[Pr.445] Cam axis phase compensation time constant	<ul style="list-style-type: none"> Set the time constant to affect the phase compensation of the cam axis. <u>Fetch cycle: At start of synchronous control</u>	<p>■Set in decimal.</p> 0 to 65535 [ms] ^{*3}	10	36484+200n	1036484+200n
[Pr.446] Synchronous control deceleration time	<ul style="list-style-type: none"> Set the deceleration time for the synchronous control. <u>Fetch cycle: At start of synchronous control</u>	<p>■Set in decimal.</p> 0 to 65535 [ms] ^{*3}	0	36485+200n	1036485+200n
[Pr.447] Output axis smoothing time constant	<ul style="list-style-type: none"> Set to smooth the output axis. <u>Fetch cycle: At start of synchronous control</u>	<p>■Set in decimal.</p> 0 to 5000 [ms]	0	36486+200n	1036486+200n

*1 Cam axis cycle units (☞ Page 126 Units for the output axis)

*2 Output axis position units (☞ Page 126 Units for the output axis)

*3 Set the value as follows in a program.

0 to 32767: Set as a decimal

32768 to 65535: Convert into a hexadecimal and set

[Pr.438] Cam axis cycle unit setting

Set the command units for the cam axis input per cycle to be used for cam control.

These units are used for setting the cam axis length per cycle and the cam axis current value per cycle.

There is no influence on the control for the parameter for monitor display.

Refer to the following.

☞ Page 125 Overview of output axis module

[Pr.439] Cam axis length per cycle

Set the length per cycle of the cam axis to generate the cam axis current value per cycle.

The unit settings are in the cam axis cycle units (☞ Page 126 Units for the output axis).

Set a value within the range from 1 to 2147483647.

The cam axis length per cycle can be changed during synchronous control by setting "1: Valid" in "[Pr.442] Cam axis length per cycle change setting". The value set in "[Pr.439] Cam axis length per cycle" is valid when the cam axis current value per cycle passes through the 0th point of cam data, or is on the 0th point.

For cam data using the coordinate data format, if the input value of the last coordinate is less than "[Pr.439] Cam axis length per cycle", the coordinate is calculated from the line segment between the nearest two coordinates from the last coordinate.

The following shows an example in the case that "[Pr.439] Cam axis length per cycle" is changed to exceed the input value of the last coordinate of cam data using the coordinate data format during synchronous control.

[Coordinate data format]

- Cam axis length per cycle: 4194304 [pulse]
- Cam stroke amount: ± 4194304 [pulse]
- Coordinate data

Point	Input value	Output value
1	0	0
2	2097152	4194304
3	4194304	0

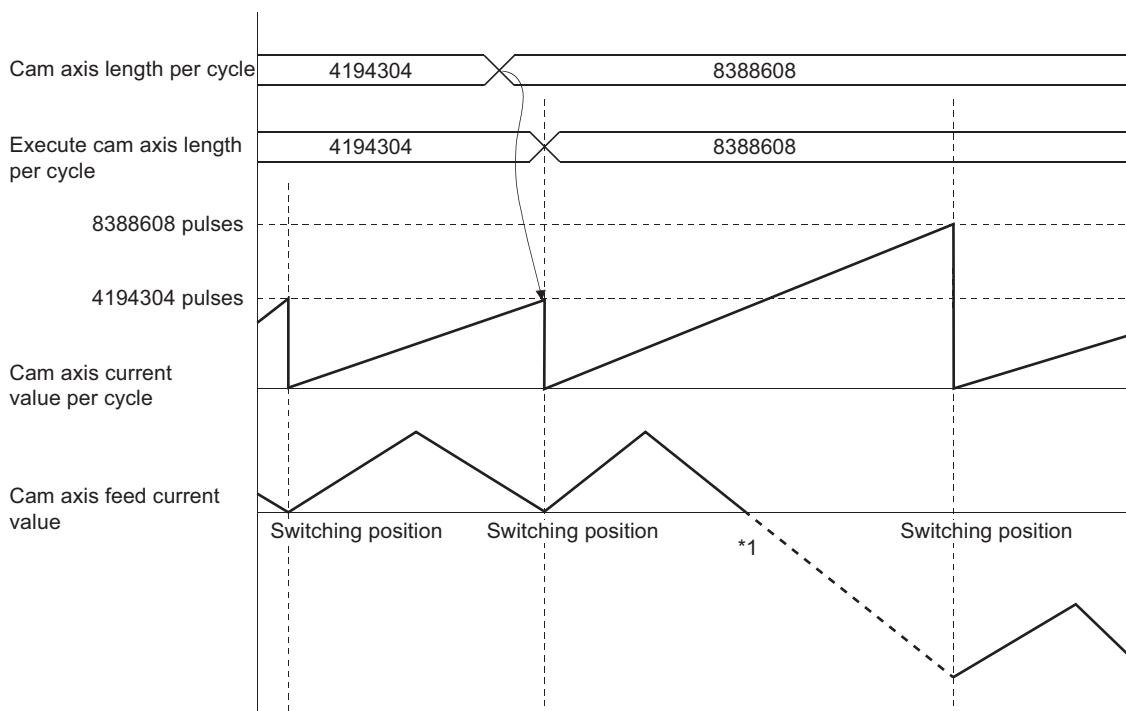

*1 The coordinate which is "an input value = a cam axis length per cycle" does not exist, so that the coordinate is calculated from the line segment between the nearest two coordinates from the last coordinate.

[Pr.440] Cam No.

Set the cam No. for cam control.

Cam No.0 operates as a linear cam for 100% of its stroke ratio along the cam axis length per cycle.

The cam No. can be changed during synchronous control.

The value set in "[Pr.440] Cam No." is valid when the cam axis current value per cycle passes through the 0th point of cam data, or is on the 0th point.

[Pr.441] Cam stroke amount

Set the cam stroke amount corresponding to a 100% stroke ratio in output axis position units ( Page 126 Units for the output axis) for cam control using the stroke ratio data format.

The cam stroke amount can be changed during synchronous control.

The value set in "[Pr.441] Cam stroke amount" is valid when the cam axis current value per cycle passes through the 0th point of cam data, or is on the 0th point.

The setting value is ignored for a cam using the coordinate data format.

[Pr.442] Cam axis length per cycle change setting

Set to change the cam axis length per cycle during synchronous control.

It can be changed for cam control using the cam No.0 (linear cam), the stroke ratio data format, and the coordinate data format. However, it cannot be changed when the cam data whose starting point is other than 0 is used for the stroke ratio data format.

Setting value	Details
0: Invalid	The cam axis length per cycle cannot be changed during synchronous control.
1: Valid	The value set in "[Pr.439] Cam axis length per cycle" is valid when the cam axis current value per cycle passes through the 0th point of cam data, or is on the 0th point.

[Pr.444] Cam axis phase compensation advance time

Set the time to advance or delay the phase of the cam axis current value per cycle in the cam control.

Setting value	Details
1 to 2147483647 [μ s]	Advance the phase according to the setting time.
0 [μ s]	Do not execute phase compensation.
-2147483648 to -1 [μ s]	Delay the phase according to the setting time.

If the setting time is too long, the system experiences overshoot or undershoot at acceleration/deceleration of the input speed. In this case, set a longer time to affect the phase compensation amount in "[Pr.445] Cam axis phase compensation time constant".

[Pr.445] Cam axis phase compensation time constant

Set the time constant to affect the phase compensation amount for the first order delay.

63 [%] of the phase compensation amount is reflected in the time constant setting.

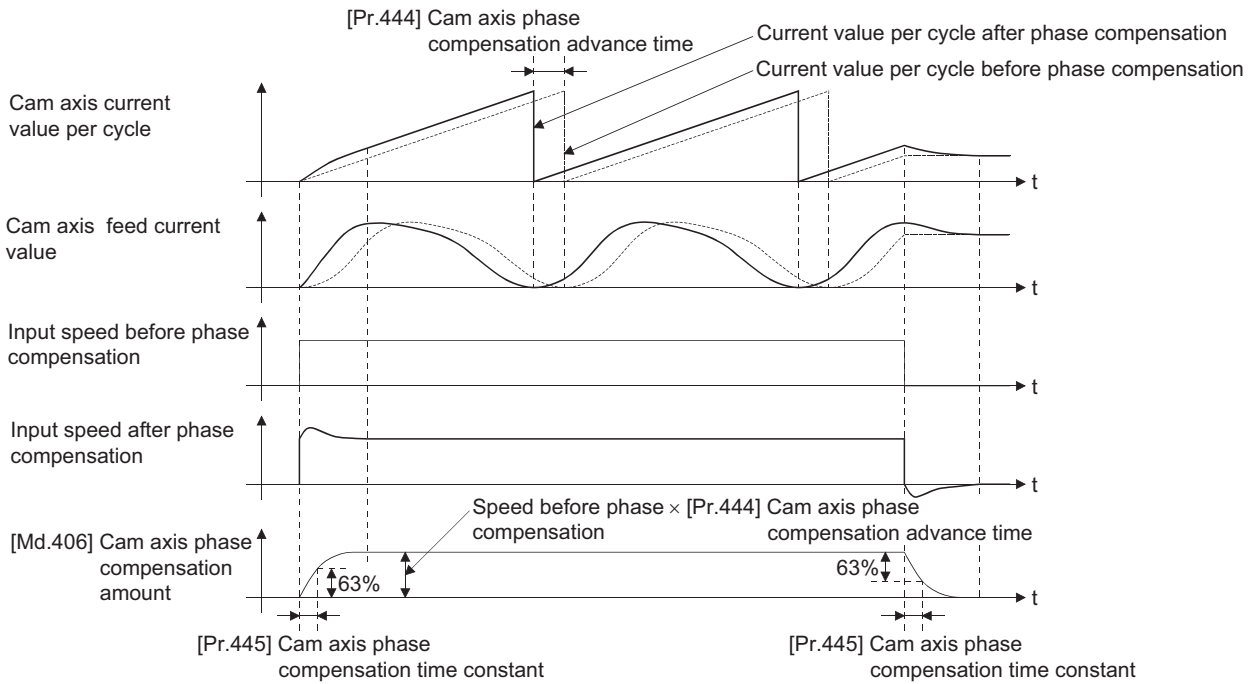

[Pr.446] Synchronous control deceleration time

Set the time to decelerate to a stop when deceleration stop occurs during synchronous control.

Set the time from "[Pr.8] Speed limit value" until the speed becomes 0 in units of ms.

Operation assumes an immediate stop when "0" is set.

[Pr.447] Output axis smoothing time constant

Set the averaging time to execute a smoothing process for the movement amount of the output axis after cam data conversion.

The smoothing process can moderate rapid speed fluctuation for cams using the coordinate data format, etc.

The input response is delayed depending on the time corresponding to the setting by smoothing process setting.

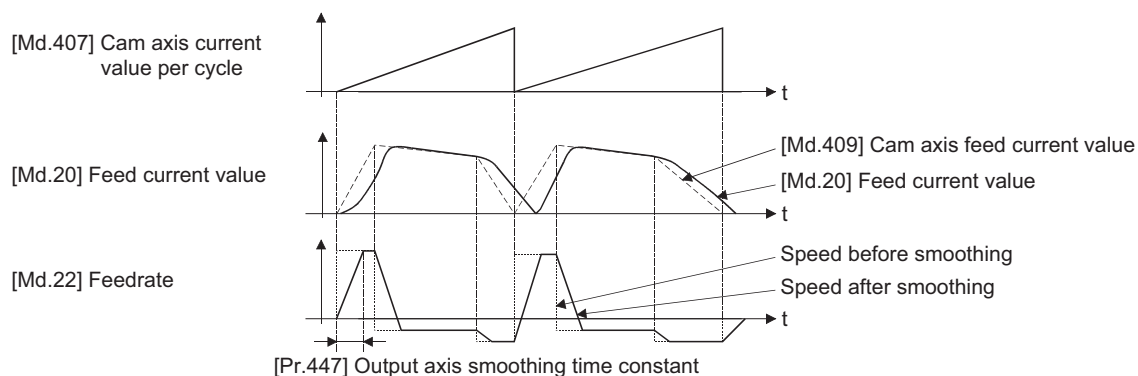

4.6 Synchronous Control Change Function

Overview of synchronous control change function

This function can change the cam reference position, the cam axis current value per cycle and the current value per cycle after the main/auxiliary shaft gear during the synchronous control.

The following 5 methods exist for the synchronous control change function. Refer to the following on each change command.

☞ Page 131 Synchronous control change control data

Synchronous control change command	Application	Output axis operation
Cam reference position movement	Adjust the cam reference position by the movement amount.	Operated
Change cam axis current value per cycle	Change the cam axis current value per cycle.	None
Change current value per cycle after main shaft gear	Change the current value per cycle after main shaft gear.	None
Change current value per cycle after auxiliary shaft gear	Change the current value per cycle after auxiliary shaft gear.	None
Cam axis current value per cycle movement	Adjust the phase of the cam axis by the movement amount.	Operated

Synchronous control change control data

n: Axis No. - 1 (n: Axis No. - 17 for axis 17 to axis 32)

Setting item	Setting details	Setting value	Default value	Buffer memory address	
				Axis 1 to axis 16	Axis 17 to axis 32
[Cd.406] Synchronous control change request	<ul style="list-style-type: none"> Set "1" to initiate a synchronous control change command request. The value is reset to "0" automatically after completion of the synchronous control change. Fetch cycle: Operation cycle	■Set in decimal. 1: Synchronous control change request	0	44086+20n	1044086+20n
[Cd.407] Synchronous control change command	<ul style="list-style-type: none"> Set the synchronous control change command. Fetch cycle: At requesting synchronous control change	■Set in decimal. 0: Cam reference position movement 1: Change cam axis current value per cycle 2: Change current value per cycle after main shaft gear 3: Change current value per cycle after auxiliary shaft gear 4: Cam axis current value per cycle movement	0	44087+20n	1044087+20n
[Cd.408] Synchronous control change value	<ul style="list-style-type: none"> Set the change value for synchronous control change processing. Fetch cycle: At requesting synchronous control change	■Set in decimal. -2147483648 to 2147483647 (Refer to the detailed explanation for units.)	0	44088+20n 44089+20n	1044088+20n 1044089+20n
[Cd.409] Synchronous control reflection time	<ul style="list-style-type: none"> Set the reflection time for synchronous control change processing. Fetch cycle: At requesting synchronous control change	■Set in decimal. 0 to 65535 [ms]*1	0	44090+20n	1044090+20n

*1 Set the value as follows in a program.
 0 to 32767: Set as a decimal.
 32768 to 65535: Convert into a hexadecimal and set.

[Cd.406] Synchronous control change request

Set "1" to initiate "[Cd.407] Synchronous control change command". The Simple Motion module resets the value to "0" automatically after completion of the synchronous control change.

The setting is initialized to "0" when starting synchronous control.

[Cd.407] Synchronous control change command

Set the synchronous control change command.

Setting value	Details	Reference
0	Cam reference position movement	Page 132 Cam reference position movement
1	Change cam axis current value per cycle	Page 132 Change cam axis current value per cycle
2	Change current value per cycle after main shaft gear	Page 133 Change current value per cycle after main shaft gear
3	Change current value per cycle after auxiliary shaft gear	Page 133 Change current value per cycle after auxiliary shaft gear
4	Cam axis current value per cycle movement	Page 133 Cam axis current value per cycle movement

■Cam reference position movement

This command is executed to move the cam reference position through adding the setting movement amount of "[Cd.408] Synchronous control change value". The movement amount to be added is averaged in "[Cd.409] Synchronous control reflection time" for its output. Set a long reflection time when a large movement amount is used since the cam axis feed current value moves with the movement amount.

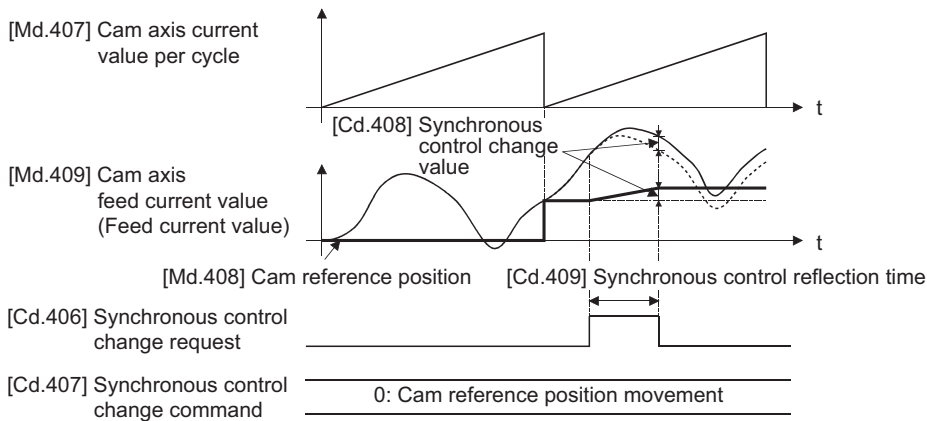

When "[Cd.406] Synchronous control change request" is reset to "0" while executing the cam reference position movement instruction, operation is stopped midway. If the cam reference position movement instruction is executed again, the remainder movement amount is not reflected, and the operation starts with "[Cd.408] Synchronous control change value" to be used again.

If synchronous control is stopped while the cam reference position movement instruction is being executed, operation also stops midway. If synchronous control is restarted, the remainder movement amount is not reflected.

■Change cam axis current value per cycle

The cam axis current value per cycle is changed to "[Cd.408] Synchronous control change value". The cam reference position will be also changed to correspond to the changed cam axis current value per cycle.

This operation is completed within one operation cycle.

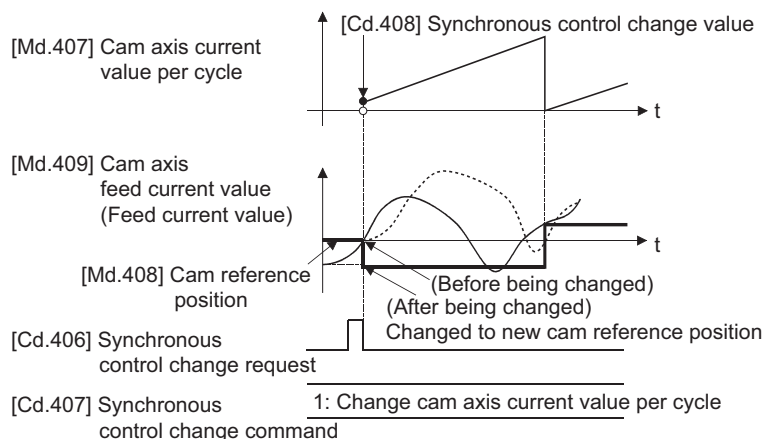

■Change current value per cycle after main shaft gear

The current value per cycle after main shaft gear is changed to the value set in "[Cd.408] Synchronous control change value". This operation is completed within one operation cycle.

Clutch control is not executed if the current value per cycle after main shaft gear (the value before being changed and after being changed) has already passed through the ON/OFF address in address mode.

■Change current value per cycle after auxiliary shaft gear

The current value per cycle after auxiliary shaft gear is changed to the value set in "[Cd.408] Synchronous control change value".

This operation is completed within one operation cycle.

Clutch control is not executed if the current value per cycle after the auxiliary shaft gear (the value before being changed and after being changed) has already passed through the ON/OFF address in address mode.

■Cam axis current value per cycle movement

This command is executed to move the cam axis current value per cycle through adding the setting movement amount of "[Cd.408] Synchronous control change value". The movement amount to be added is averaged in "[Cd.409] Synchronous control reflection time" for its output.

Set a long reflection time when a large movement amount is used since the cam axis feed current value moves with the movement amount.

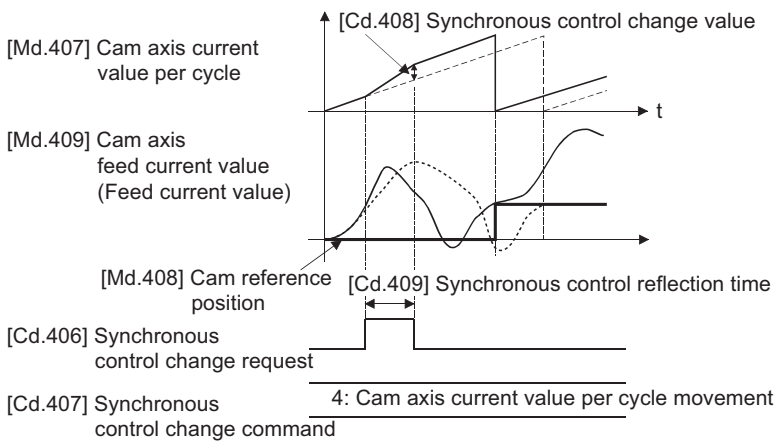

[Cd.408] Synchronous control change value

Set the change value for synchronous control change processing as follows.

[Cd.407] Synchronous control change command	[Cd.408] Synchronous control change value		
	Setting range	Unit	Setting details
0: Cam reference position movement	-2147483648 to 2147483647	Output axis position unit	<ul style="list-style-type: none"> Set the movement amount of the cam reference position. It moves within the range from -2147483648 to 2147483647.
1: Change cam axis current value per cycle		Cam axis cycle unit	<ul style="list-style-type: none"> Set the change current value per cycle. The setting value is converted within the range from 0 to (Cam axis length per cycle - 1).
2: Change current value per cycle after main shaft gear			
3: Change current value per cycle after auxiliary shaft gear			
4: Cam axis current value per cycle movement		<ul style="list-style-type: none"> Set the movement amount of the cam axis current value per cycle. It moves within the range from -2147483648 to 2147483647. 	

[Cd.409] Synchronous control reflection time

Set the reflection time for synchronous control change processing as follows.

[Cd.407] Synchronous control change command	Setting details for "[Cd.409] Synchronous control reflection time"
0: Cam reference position movement	The time to reflect the movement amount to the cam reference position.
1: Change cam axis current value per cycle	Setting not required.
2: Change current value per cycle after main shaft gear	
3: Change current value per cycle after auxiliary shaft gear	
4: Cam axis current value per cycle movement	The time to reflect the movement amount to the cam axis current value per cycle.

4.7 Synchronous Control Monitor Data

Synchronous control monitor data is updated only during synchronous control.

The monitor values ([Md.400], [Md.401], [Md.402], [Md.407], [Md.408], and [Md.409]) from the last synchronous control session are restored the next time the system's power supply turns ON. Restarting operation status from the last synchronous control session is possible through returning to the last position via positioning control ( Page 143 ADVANCED SYNCHRONOUS CONTROL INITIAL POSITION).

"The last synchronous control session" indicates status just before the last synchronous control session was stopped as follows. These are listed with the last synchronization status.

- Just before "[Cd.380] Synchronous control start" turns from ON to OFF.
- Just before deceleration stop by a stop command or an error, etc.
- Just before the system's power supply turned OFF to the Simple Motion module.

n: Axis No. - 1 (n: Axis No. - 17 for axis 17 to axis 32)

Monitor item	Storage details	Monitor value	Buffer memory address	
			Axis 1 to axis 16	Axis 17 to axis 32
[Md.400] Current value after composite main shaft gear	<ul style="list-style-type: none"> • The current value after combining the main input and sub input values from the main shaft is stored. • Value is stored even after system's power supply OFF. Refresh cycle: Operation cycle (During synchronous control only)	■Monitoring is carried out in decimal display. -2147483648 to 2147483647 [Main input axis position units ^{*1}]	42800+40n 42801+40n	1042800+40n 1042801+40n
[Md.401] Current value per cycle after main shaft gear	<ul style="list-style-type: none"> • The current value per cycle after the main shaft gear is stored. • One cycle is considered the cam axis length per cycle. • Value is stored even after system's power supply OFF. Refresh cycle: Operation cycle (During synchronous control only)	■Monitoring is carried out in decimal display. 0 to (Cam axis length per cycle - 1) [Cam axis cycle units ^{*2}]	42802+40n 42803+40n	1042802+40n 1042803+40n
[Md.402] Current value per cycle after auxiliary shaft gear	<ul style="list-style-type: none"> • The current value per cycle after the auxiliary shaft gear is stored. • One cycle is considered the cam axis length per cycle. • Value is stored even after system's power supply OFF. Refresh cycle: Operation cycle (During synchronous control only)	■Monitoring is carried out in decimal display. 0 to (Cam axis length per cycle - 1) [Cam axis cycle units ^{*2}]	42804+40n 42805+40n	1042804+40n 1042805+40n
[Md.406] Cam axis phase compensation amount	<ul style="list-style-type: none"> • The current phase compensation amount is stored. Refresh cycle: Operation cycle (During synchronous control only)	■Monitoring is carried out in decimal display. -2147483648 to 2147483647 [Cam axis cycle units ^{*2}]	42810+40n 42811+40n	1042810+40n 1042811+40n
[Md.407] Cam axis current value per cycle	<ul style="list-style-type: none"> • The current value per cycle is stored, which is calculated from the input movement amount to the cam axis. (The value after phase compensation) • Value is stored even after system's power supply OFF. Refresh cycle: Operation cycle (During synchronous control only)	■Monitoring is carried out in decimal display. 0 to (Cam axis length per cycle - 1) [Cam axis cycle units ^{*2}]	42812+40n 42813+40n	1042812+40n 1042813+40n
[Md.408] Cam reference position	<ul style="list-style-type: none"> • The feed current value as the cam reference position is stored. • Value is stored even after system's power supply OFF. Refresh cycle: Operation cycle (During synchronous control only)	■Monitoring is carried out in decimal display. -2147483648 to 2147483647 [Output axis position units ^{*3}]	42814+40n 42815+40n	1042814+40n 1042815+40n
[Md.409] Cam axis feed current value	<ul style="list-style-type: none"> • The feed current value while controlling the cam axis is stored. • Value is stored even after system's power supply OFF. Refresh cycle: Operation cycle (During synchronous control only)	■Monitoring is carried out in decimal display. -2147483648 to 2147483647 [Output axis position units ^{*3}]	42816+40n 42817+40n	1042816+40n 1042817+40n

Monitor item	Storage details	Monitor value	Buffer memory address	
			Axis 1 to axis 16	Axis 17 to axis 32
[Md.410] Execute cam No.	• The executing cam No. is stored. <u>Refresh cycle: Operation cycle (During synchronous control only)</u>	■Monitoring is carried out in decimal display. 0 to 256 [RD77MS] 0 to 1024 [RD77GF]	42818+40n	1042818+40n
[Md.411] Execute cam stroke amount	• The executing cam stroke amount is stored. <u>Refresh cycle: Operation cycle (During synchronous control only)</u>	■Monitoring is carried out in decimal display. -2147483648 to 2147483647 [Output axis position units ^{*3}]	42820+40n 42821+40n	1042820+40n 1042821+40n
[Md.412] Execute cam axis length per cycle	• The executing cam axis length per cycle is stored. <u>Refresh cycle: Operation cycle (During synchronous control only)</u>	■Monitoring is carried out in decimal display. 1 to 2147483647 [Cam axis cycle units ^{*2}]	42822+40n 42823+40n	1042822+40n 1042823+40n
[Md.420] Phase Compensation Function	• The clutch ON/OFF status is stored. <u>Refresh cycle: Operation cycle (During synchronous control only)</u>	■Monitoring is carried out in decimal display. 0: Clutch OFF status 1: Clutch ON status	42828+40n	1042828+40n
[Md.421] Main shaft clutch smoothing status	• The smoothing status of the clutch is stored. <u>Refresh cycle: Operation cycle (During synchronous control only)</u>	■Monitoring is carried out in decimal display. 0: Clutch OFF status 1: Clutch ON status	42829+40n	1042829+40n
[Md.422] Main shaft clutch smoothing status	• The smoothing status of main shaft clutch is stored. <u>Refresh cycle: Operation cycle (During synchronous control only)</u>	■Monitoring is carried out in decimal display. -2147483648 to 2147483647 [Main input axis position units ^{*1}] or Cam axis cycle units ^{*2}]	42830+40n 42831+40n	1042830+40n 1042831+40n
[Md.423] Auxiliary shaft clutch ON/OFF status	• The ON/OFF status of the auxiliary shaft clutch is stored. <u>Refresh cycle: Operation cycle (During synchronous control only)</u>	■Monitoring is carried out in decimal display. 0: Clutch OFF status 1: Clutch ON status	42832+40n	1042832+40n
[Md.424] Auxiliary shaft clutch smoothing status	• The smoothing status of the auxiliary shaft clutch is stored. <u>Refresh cycle: Operation cycle (During synchronous control only)</u>	■Monitoring is carried out in decimal display. 0: Not on clutch smoothing 1: On clutch smoothing	42833+40n	1042833+40n
[Md.425] Auxiliary shaft clutch slippage (accumulative)	• The accumulative slippage on the auxiliary shaft clutch smoothing with slippage method is stored as a signed value. <u>Refresh cycle: Operation cycle (During synchronous control only)</u>	■Monitoring is carried out in decimal display. -2147483648 to 2147483647 [Auxiliary shaft position units ^{*4} or Cam axis cycle units ^{*2}]	42834+40n 42835+40n	1042834+40n 1042835+40n

*1 Main input axis position units ( Page 28 INPUT AXIS MODULE)

*2 Cam axis cycle units ( Page 126 Units for the output axis)

*3 Output axis position units ( Page 126 Units for the output axis)

*4 Auxiliary shaft position units ( Page 28 INPUT AXIS MODULE)

[Md.400] Current value after composite main shaft gear

The current value after combining the main input and the sub input values going into the composite main shaft gear is stored as an accumulative value.

Units are in position units of the main input axis (☞ Page 28 INPUT AXIS MODULE). The unit is pulse if the main input axis is invalid.

The current value after composite main shaft gear will be changed when the following operations are executed in the main input axis during synchronous control.

Operations of main input axis (Synchronous control)	Servo input axis		Synchronous encoder axis
	Absolute position detection system: valid	Absolute position detection system: invalid	
Home position return	Change method 1)		—
Current value change	Change method 1)		Change method 1)
Speed control*1	Change method 1)		—
Fixed-pitch feed control	Change method 1)		—
Speed-position switching control*1	Change method 1)		—
Position-speed switching control*1	Change method 1)		—
Connection to servo amplifier	Change method 2)	Change method 1)	—
Connection to synchronous encoder	—		Change method 1)

*1 When "2: Clear feed current value to zero" is set in "[Pr.21] Feed current value during speed control" only.

Change method 1): The new current value after composite main shaft gear is calculated based on the current value of the main input axis.

Current value after composite main shaft gear = Main input direction of composite main shaft gear × Main input axis current value

Change method 2): The movement amount of the main input axis from the last synchronous control session is reflected to the current value after composite main shaft gear.

Current value after composite main shaft gear = Current value after composite main shaft gear × Movement amount of main input axis from the last synchronous control session

[Md.401] Current value per cycle after main shaft gear

The input movement amount after the main shaft gear is stored within the range from 0 to (Cam axis length per cycle - 1). The unit is in cam axis cycle units ( Page 126 Units for the output axis).

The value is restored according to "[Pr.460] Setting method of current value per cycle after main shaft gear" when starting synchronous control. ( Page 143 Synchronous Control Initial Position)

[Md.402] Current value per cycle after auxiliary shaft gear

The input movement amount after the auxiliary shaft gear is stored within the range from 0 to (Cam axis length per cycle - 1).

The unit is in cam axis cycle units ( Page 126 Units for the output axis).

The value is restored according to "[Pr.461] Setting method of current value per cycle after auxiliary shaft gear" when starting synchronous control. ( Page 143 Synchronous Control Initial Position)

[Md.406] Cam axis phase compensation amount

The phase compensation amount for the cam axis is stored with cam axis cycle units ( Page 126 Units for the output axis).

The phase compensation amount after smoothing processing with "[Pr.445] Cam axis phase compensation time constant" is stored.

[Md.407] Cam axis current value per cycle

The cam axis current value per cycle is stored within the range from 0 to (Cam axis length per cycle - 1).

The current value after cam axis phase compensation processing can be monitored. The unit is in cam axis cycle units ( Page 126 Units for the output axis).

The value is restored according to "[Pr.462] Cam axis position restoration object" when starting synchronous control.

( Page 143 Synchronous Control Initial Position)

[Md.408] Cam reference position

The feed current value is stored as the cam reference position. The unit is in output axis position units ( Page 126 Units for the output axis). When the unit is in degrees, a range from 0 to 35999999 is used.

The value is restored according to "[Pr.462] Cam axis position restoration object" when starting synchronous control.

( Page 143 Synchronous Control Initial Position)

[Md.409] Cam axis feed current value

The feed current value of the cam axis is stored. The value is the same as "[Md.20] Feed current value" during synchronous control.

[Md.410] Execute cam No.

The executing cam No. is stored.

When "[Pr.440] Cam No." is changed during synchronous control, this is updated when the controlling cam No. switches.

[Md.411] Execute cam stroke amount

The executing cam stroke amount is stored.

When "[Pr.441] Cam stroke amount" is changed during synchronous control, this is updated when the controlling cam stroke amount switches.

[Md.412] Execute cam axis length per cycle

The executing cam axis length per cycle is stored.

When "[Pr.439] Cam axis length per cycle" is changed during synchronous control, this is updated when the controlling cam axis length per cycle switches.

[Md.420] Main shaft clutch ON/OFF status

The clutch ON/OFF status is stored.

[Md.421] Main shaft clutch smoothing status

The smoothing status of the clutch is stored. The status is updated by the clutch smoothing method as follows.

Method	Details
Time constant method	The status is always "1: On clutch smoothing" during the clutch ON status. The status will be "0: Not on clutch smoothing" when the clutch is turned OFF and smoothing is completed.
Slippage method	The status is "1: On clutch smoothing" till the clutch accumulative slippage amount reaches the slippage at clutch ON when the clutch is turned ON. The status will change to "0: Not on clutch smoothing" when the clutch accumulative slippage amount reaches the slippage at clutch ON. The status is "1: On clutch smoothing" till the clutch accumulative slippage amount reaches 0 when the clutch is turned OFF. The status will change to "0: Not on clutch smoothing" when the clutch accumulative slippage amount reaches 0.

[Md.422] Main shaft clutch slippage (accumulative)

The accumulative slippage amount with the slippage method is stored as a signed value.

The absolute value of the accumulative slippage increases to reach the slippage at clutch ON during clutch ON.

The absolute value of the accumulative slippage decreases to reach 0 during clutch OFF.

Monitoring of the accumulative slippage is used to check the smoothing progress with the slippage method.

[Md.423] Auxiliary shaft clutch ON/OFF status

The clutch ON/OFF status is stored.

[Md.424] Auxiliary shaft clutch smoothing status

The smoothing status of the clutch is stored. The status is updated by the clutch smoothing method as follows.

Method	Details
Time constant method	The status is always "1: On clutch smoothing" during the clutch ON status. The status will be "0: Not on clutch smoothing" when the clutch is turned OFF and smoothing is completed.
Slippage method	The status is "1: On clutch smoothing" till the clutch accumulative slippage amount reaches the slippage at clutch ON when the clutch is turned ON. The status will change to "0: Not on clutch smoothing" when the clutch accumulative slippage amount reaches the slippage at clutch ON. The status is "1: On clutch smoothing" till the clutch accumulative slippage amount reaches 0 when the clutch is turned OFF. The status will change to "0: Not on clutch smoothing" when the clutch accumulative slippage amount reaches 0.

[Md.425] Auxiliary shaft clutch slippage (accumulative)

The accumulative slippage amount with the slippage method is stored as a signed value.

The absolute value of the accumulative slippage increases to reach the slippage at clutch ON during clutch ON.

The absolute value of the accumulative slippage decreases to reach 0 during clutch OFF.

Monitoring of the accumulative slippage is used to check the smoothing progress with the slippage method.

4.8 Phase Compensation Function

In synchronous control, delays in progresses, etc. cause the phase to deviate at the output axis motor shaft end with respect to the input axis (servo input axis or synchronous encoder axis). The phase compensation function compensates in this case so that the phase does not deviate.

Phase compensation can be set for the input and the output axis. It is possible to compensate using the delay time inherent to the system based on the servo input axis or the synchronous encoder axis on the input axis side. It is also possible to use a compensation delay time equivalent to the position deviation for each servo amplifier on the output axis side.

Phase compensation of delay time of the input axis

Set delay time inherent to the system in the phase compensation advance time of the input axis ("[Pr.302] Servo input axis phase compensation advance time", "[Pr.326] Synchronous encoder axis phase compensation advance time").

The delay time inherent to the system is shown below.

■ Delay time inherent to the system for a servo input axis

- RD77MS

Operation cycle [ms]	[Pr.300] Servo input axis type			
	Feed current value	Real current value	Command to servo amplifier	Feedback value
0.444	0 [μs]	943 [μs]	0 [μs]	1833 [μs]
0.888	0 [μs]	1834 [μs]	0 [μs]	3612 [μs]
1.777	0 [μs]	1833 [μs]	0 [μs]	5389 [μs]
3.555	0 [μs]	1833 [μs]	0 [μs]	8944 [μs]

- RD77GF

Operation cycle [ms]	[Pr.300] Servo input axis type			
	Feed current value	Real current value	Command to servo amplifier	Feedback value
0.50	0 [μs]	1811 [μs]	0 [μs]	2814 [μs]
1.00	0 [μs]	2779 [μs]	0 [μs]	4780 [μs]
2.00	0 [μs]	4726 [μs]	0 [μs]	8726 [μs]
4.00	0 [μs]	8730 [μs]	0 [μs]	16736 [μs]

■ Delay time inherent to the system for a synchronous encoder axis

- RD77MS

Operation cycle [ms]	[Pr.320] Synchronous encoder axis type		
	Incremental synchronous encoder	Synchronous encoder via servo amplifier	Synchronous encoder via CPU
0.444	1164 [μs]	1875 [μs]	1164 + Scan time [μs]
0.888	2433 [μs]	3655 [μs]	2433 + Scan time [μs]
1.777	4124 [μs]	5432 [μs]	4124 + Scan time [μs]
3.555	7676 [μs]	8986 [μs]	7676 + Scan time [μs]

- RD77GF

Operation cycle [ms]	[Pr.320] Synchronous encoder axis type		
	Synchronous encoder via servo amplifier	Synchronous encoder via CPU	Synchronous encoder via link device
0.50	2874 [μs]	498 + Scan time [μs]	495 [μs]
1.00	4777 [μs]	998 + Scan time [μs]	993 [μs]
2.00	8722 [μs]	1999 + Scan time [μs]	1992 [μs]
4.00	16722 [μs]	3999 + Scan time [μs]	3992 [μs]

Phase compensation of delay time of the output axis

Set delay time equivalent to the position deviation on the servo amplifier in "[Pr.444] Cam axis phase compensation advance time" for the output axis. The delay time equivalent to position deviation of the servo amplifier is calculated using the following formula. (When using MR-J3(W)-B, MR-J4(W)-B, MR-JE-B(F), and MR-J4-GF)

Delay time [μ s] = 1000000 / Servo parameter "Model loop gain (PB07)"

When the feed forward gain is set, the delay time is set to a smaller value than the value listed above.

The model loop gain will change when the gain adjustment method is auto tuning mode 1 or 2. The model loop gain must not be changed on the axis executing phase compensation through preventing change with the manual mode or interpolation mode setting.

Setting example

When axis 1 is synchronized with an incremental synchronous encoder axis, the phase compensation advance time is set as follows.

(If the operation cycle is as 1.77 [ms] and model loop gain of axis 1 is as 80.)

Setting item	Setting value
[Pr.326] Synchronous encoder axis phase compensation advance time	Set delay time inherent to the system for a synchronous encoder axis. Refer to the following for the delay time inherent to the system for a synchronous encoder axis.  Page 140 Delay time inherent to the system for a synchronous encoder axis
[Pr.444] Cam axis phase compensation advance time	1000000 / 80 = 12500 [μ s]

When overshoot or undershoot occurs during acceleration/deceleration, set a longer time for the phase compensation time constant.

4.9 Output Axis Sub Functions

The following shows which sub functions apply for the output axis in synchronous control.

○: Valid, —: Invalid

Sub function	Output axis	Details
Backlash compensation function	○	The same control as other methods.
Electronic gear function	○	
Speed limit function	—	Setting is ignored. ("[Pr.8] Speed limit value" must be set to use "[Pr.446] Synchronous control deceleration time".)
Torque limit function	○	Controlled with "[Pr.17] Torque limit setting value" or "[Cd.101] Torque output setting value" similar to other methods.
Software stroke limit function	○	The axis stops immediately when exceeding the software stroke limit range. To disable the software stroke limit, set the setting value so that "Upper limit value = Lower limit value".
Hardware stroke limit function	○	Controlled the same as positioning control.
Forced stop function	○	Same control as other methods.
Speed change function	—	Setting is ignored.
Override function	—	
Acceleration/deceleration time change function	—	
Torque change function	○	
Absolute system	○	Same control as other methods.
Step function	—	
Skip function	—	
M code output function	—	M code is not able to output.
Teaching function	—	Setting is ignored.
Target position change function	—	
Command in-position function	—	
Acceleration/deceleration processing function	○	Valid at deceleration stop only. Deceleration time is set in "[Pr.446] Synchronous control deceleration time".
Pre-reading start function	—	Setting is ignored.
Deceleration start flag function	—	
Stop command processing for deceleration stop function	—	
Speed control 10 x multiplier setting for degree axis function	○	Reflected on monitor data.
Operation setting for incompletion of home position return function	○	Controlled the same as positioning control. For a system that needs alignment, start synchronous control after establishing an a home position.
Servo ON/OFF	○	Servo OFF request is ignored during synchronous control s imilar to positioning control.

Point

Sub functions for an input axis in synchronous control conform to the specification of each control (Home position return control, Positioning control, Manual control, Speed torque control). Refer to the following for details.

 MELSEC iQ-R Simple Motion Module User's Manual (Application)

5 ADVANCED SYNCHRONOUS CONTROL INITIAL POSITION

The initial position for synchronous control is explained in this chapter.

Configure these settings for situations that require initial position alignment for synchronous control.

5.1 Synchronous Control Initial Position

The following synchronous control monitor data can be aligned to a set position when starting synchronous control, as the initial position for synchronous control.

The alignment to a synchronous control initial position is useful for restoring a system based on the last control status along with restarting synchronous control after canceling midway.

Synchronous control monitor data	The position when starting synchronous control
[Md.400] Current value after composite main shaft gear	Restored to a position based on the main input axis of the main shaft.
[Md.401] Current value per cycle after main shaft gear	Restored according to "[Pr.460] Setting method of current value per cycle after main shaft gear".
[Md.402] Current value per cycle after auxiliary shaft gear	Restored according to "[Pr.461] Setting method of current value per cycle after auxiliary shaft gear".
[Md.407] Cam axis current value per cycle	Restored according to "[Pr.462] Cam axis position restoration object".
[Md.408] Cam reference position	
[Md.409] Cam axis feed current value	

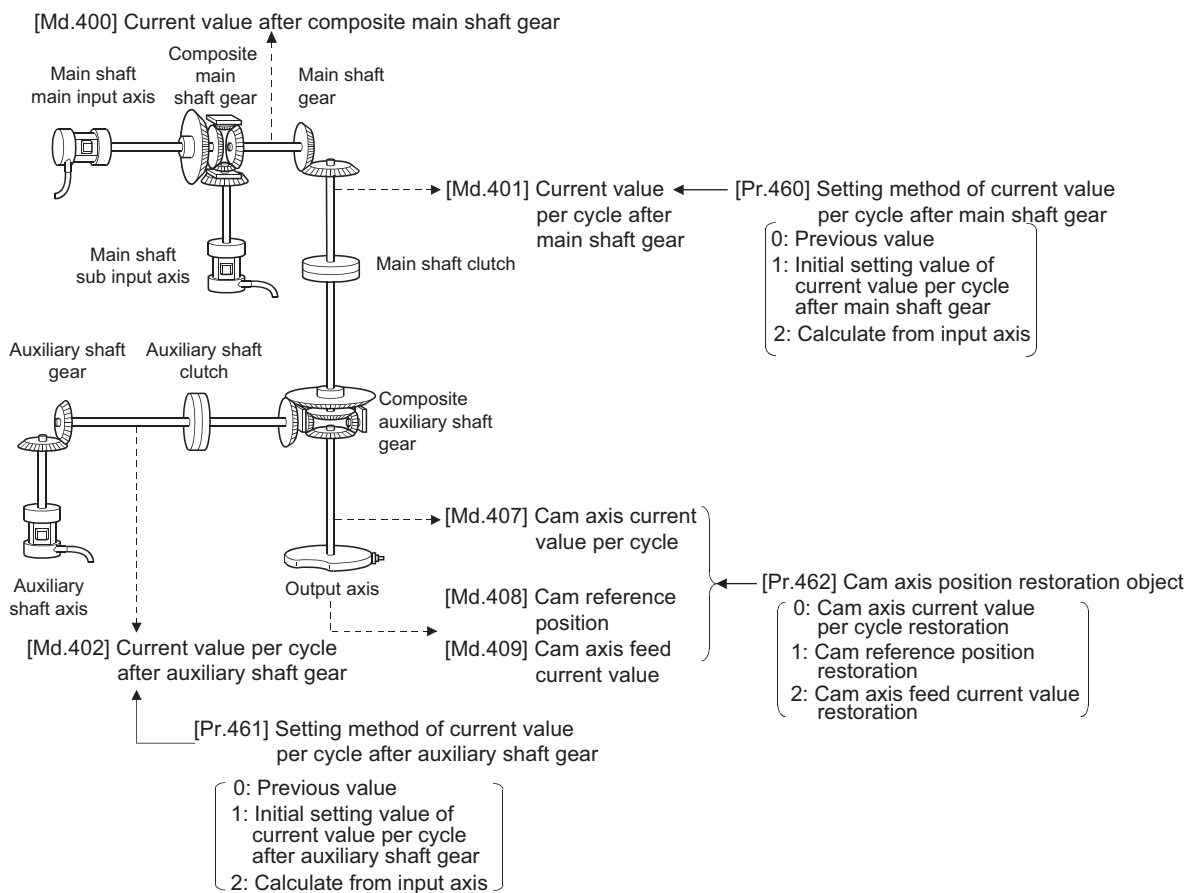

Current value after composite main shaft gear at synchronous control start

The current value after composite main shaft gear is restored as follows according to the main input axis operation executed before starting synchronous control.

Operation of main input axis (Before synchronous control start)	Servo input axis		Synchronous encoder axis
	Absolute position detection system valid	Absolute position detection system invalid	
Home position return	Restoration method 1)		—
Current value change	Restoration method 1)		Restoration method 1)
Speed control*1	Restoration method 1)		—
Fixed-pitch feed control	Restoration method 1)		—
Speed-position switching control*1	Restoration method 1)		—
Position-speed switching control*1	Restoration method 1)		—
Connection to servo amplifier	Restoration method 2)	Restoration method 1)	—
Connection to synchronous encoder	—		Restoration method 1)
Others	Restoration method 2)		Restoration method 2)

*1 When "[Pr.300] Servo input axis type" is either "1: Feed current value" or "2: Real current value", and when "[Pr.21] Feed current value during speed control" is "2: Clear feed current value to zero" only.

Restoration method 1): The new current value after composite main shaft gear is calculated based on the current value of the main input axis.

Current value after composite main shaft gear =

Main input direction of composite main shaft gear × Main input axis current value

Restoration method 2): The movement amount of the main input axis from the last synchronous control session is reflected to the current value after composite main shaft gear.

Current value after composite main shaft gear =

Current value after composite main shaft gear at the last synchronous control session + Main input direction of composite main shaft gear × Amount of change of main input axis current value from the last synchronous control session

The current value after composite main shaft gear at the last synchronous control session is restored when "0: Invalid" is set in "[Pr.400] Main input axis No.", or when a servo input axis or a synchronous encoder axis as the main input axis is not connected.

Point

"The last synchronous control session" indicates status just before the last synchronous control session was stopped as follows. These are listed with the last synchronization status.

- Just before "[Cd.380] Synchronous control start" turns from ON to OFF.
- Just before deceleration stop by a stop command or an error, etc.
- Just before the system's power supply turned OFF to the Simple Motion module.

Current value per cycle after main/auxiliary shaft gear at synchronous control start

The current value per cycle after main shaft gear/current value per cycle after auxiliary shaft gear is restored as follows according to the main input axis/auxiliary shaft operation executed before starting synchronous control.

Operation of main input axis/ auxiliary shaft (Before synchronous control start)	Servo input axis		Synchronous encoder axis
	Absolute position detection system valid	Absolute position detection system invalid	
Home position return	Restoration method 1)		—
Current value change	Restoration method 1)		Restoration method 1)
Speed control ^{*1}	Restoration method 1)		—
Fixed-pitch feed control	Restoration method 1)		—
Speed-position switching control ^{*1}	Restoration method 1)		—
Position-speed switching control ^{*1}	Restoration method 1)		—
Connection to servo amplifier	Restoration method 2)	Restoration method 1)	—
Connection to synchronous encoder	—		Restoration method 1)
Others	Restoration method 2)		Restoration method 2)

*1 When "[Pr.300] Servo input axis type" is either "1: Feed current value" or "2: Real current value", and when "[Pr.21] Feed current value during speed control" is "2: Clear feed current value to zero" only.

Restoration method 1): The new value of the current value per cycle after main shaft gear/current value per cycle after auxiliary shaft gear is calculated based on the current value after composite main shaft gear/auxiliary shaft current value.

[Main shaft]

Current value per cycle after main shaft gear = Main shaft gear ratio × Current value after composite main shaft gear

[Auxiliary shaft]

Current value per cycle after auxiliary shaft gear = Auxiliary shaft gear ratio × Auxiliary shaft current value

Restoration method 2): The movement amount from the last synchronous control session is reflected to the current value per cycle after main shaft gear/current value per cycle after auxiliary shaft gear.

[Main shaft]

Current value per cycle after main shaft gear =

Current value per cycle after main shaft gear at the last synchronous control session + Main shaft gear ratio × Amount of change of current value after composite main shaft gear from the last synchronous control session

[Auxiliary shaft]

Current value per cycle after auxiliary shaft gear =

Current value per cycle after auxiliary shaft gear at the last synchronous control session + Auxiliary shaft gear ratio × Amount of change of auxiliary shaft current value from the last synchronous control session

The current value per cycle after main shaft gear/current value per cycle after auxiliary shaft gear at the last synchronous control session is restored when "0: Invalid" is set in "[Pr.400] Main input axis No."/[Pr.418] Auxiliary shaft axis No.", or when a servo input axis or a synchronous encoder axis as the main input axis/auxiliary shaft is not connected.

Cam axis position at synchronous control start

The cam axis position is composed of the relationship of 3 positions "Cam axis current value per cycle", "Cam reference position" and "Cam axis feed current value". One of positions can be restored by defining 2 positions when starting synchronous control.

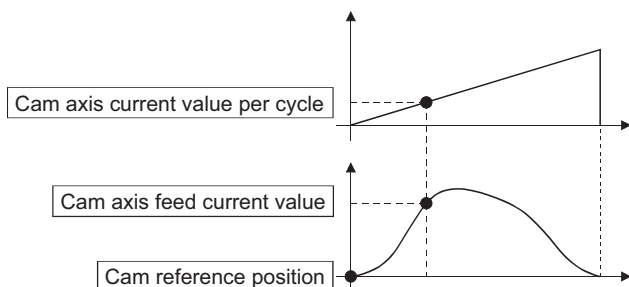

Select from 3 objects as follows in "[Pr.462] Cam axis position restoration object" which position is to be restored. (Refer to [Page 150](#) Cam Axis Position Restoration Method for details on the restoration method.)

- Cam axis current value per cycle restoration
- Cam reference position restoration
- Cam axis feed current value restoration

Various parameters need to be set for the cam axis position restoration as shown below. (Refer to [Page 147](#) Synchronous Control Initial Position Parameters for the setting details.)

○: Required, △: Required for initial setting value, —: Not required

[Pr.462] Cam axis position restoration object	[Pr.463] Setting method of cam reference position	[Pr.467] Cam reference position (Initial setting)	[Pr.464] Setting method of cam axis current value per cycle	[Pr.468] Cam axis current value per cycle (Initial setting)	Restoration processing details
0: Cam axis current value per cycle restoration	○	△	—	○ (Used as search starting point)	Restore "Cam axis current value per cycle" based on "Cam reference position" and "Cam axis feed current value".
1: Cam reference position restoration	—	—	○	△	Restore "Cam reference position" based on "Cam axis current value per cycle" and "Cam axis feed current value".
2: Cam axis feed current value restoration	○	△	○	△	Restore "Cam axis feed current value" based on "Cam axis current value per cycle" and "Cam reference position".

5.2 Synchronous Control Initial Position Parameters

n: Axis No. - 1 (n: Axis No. - 17 for axis 17 to axis 32)

Setting item	Setting details	Setting value	Default value	Buffer memory address	
				Axis 1 to axis 16	Axis 17 to axis 32
[Pr.460] Setting method of current value per cycle after main shaft gear	<ul style="list-style-type: none"> Select the setting method for the current value per cycle after main shaft gear. <u>Fetch cycle: At start of synchronous control</u>	<ul style="list-style-type: none"> Set in decimal. 0: Previous value 1: Initial setting value of current value per cycle after main shaft gear ([Pr.465]) 2: Calculate from input axis 	0	36500+200n	1036500+200n
[Pr.461] Setting method of current value per cycle after auxiliary shaft gear	<ul style="list-style-type: none"> Select the setting method for the current value per cycle after auxiliary shaft gear. <u>Fetch cycle: At start of synchronous control</u>	<ul style="list-style-type: none"> Set in decimal. 0: Previous value 1: Initial setting value of current value per cycle after auxiliary shaft gear ([Pr.466]) 2: Calculate from input axis 	0	36501+200n	1036501+200n
[Pr.462] Cam axis position restoration object	<ul style="list-style-type: none"> Select the object to restore the cam axis position. <u>Fetch cycle: At start of synchronous control</u>	<ul style="list-style-type: none"> Set in decimal. 0: Cam axis current value per cycle restoration 1: Cam reference position restoration 2: Cam axis feed current value restoration 	0	36502+200n	1036502+200n
[Pr.463] Setting method of cam reference position	<ul style="list-style-type: none"> Select the setting method for the cam reference position. Set for the cam axis current value per cycle restoration or the cam axis feed current value restoration <u>Fetch cycle: At start of synchronous control</u>	<ul style="list-style-type: none"> Set in decimal. 0: Previous value 1: Initial setting value of cam reference position 2: Feed current value 	2	36503+200n	1036503+200n
[Pr.464] Setting method of cam axis current value per cycle	<ul style="list-style-type: none"> Select the setting method for the cam axis current value per cycle. Set for the cam reference position restoration or the cam axis feed current value restoration. <u>Fetch cycle: At start of synchronous control</u>	<ul style="list-style-type: none"> Set in decimal. 0: Previous value 1: Initial setting value of cam axis current value per cycle 2: Current value per cycle after main shaft gear 3: Current value per cycle after auxiliary shaft gear 	0	36504+200n	1036504+200n
[Pr.465] Current value per cycle after main shaft gear (Initial setting)	<ul style="list-style-type: none"> Set the initial value of the current value per cycle after main shaft gear. <u>Fetch cycle: At start of synchronous control</u>	<ul style="list-style-type: none"> Set in decimal. 0 to (Cam axis length per cycle - 1) [Cam axis cycle units^{*1}] 	0	36506+200n 36507+200n	1036506+200n 1036507+200n
[Pr.466] Current value per cycle after auxiliary shaft gear (Initial setting)	<ul style="list-style-type: none"> Set the initial value of the current value per cycle after auxiliary shaft gear. <u>Fetch cycle: At start of synchronous control</u>	<ul style="list-style-type: none"> Set in decimal. 0 to (Cam axis length per cycle - 1) [Cam axis cycle units^{*1}] 	0	36508+200n 36509+200n	1036508+200n 1036509+200n
[Pr.467] Cam reference position (Initial setting)	<ul style="list-style-type: none"> Set the initial value of the cam reference position. <u>Fetch cycle: At start of synchronous control</u>	<ul style="list-style-type: none"> Set in decimal. -2147483648 to 2147483647 [Output axis position units^{*2}] 	0	36510+200n 36511+200n	1036510+200n 1036511+200n
[Pr.468] Cam axis current value per cycle (Initial setting)	<ul style="list-style-type: none"> Set the initial value for the cam axis current value per cycle. The restoration value for the cam axis current value per cycle is searched from the setting value with the cam axis current value per cycle restoration. <u>Fetch cycle: At start of synchronous control</u>	<ul style="list-style-type: none"> Set in decimal. 0 to (Cam axis length per cycle - 1) [Cam axis cycle units^{*1}] 	0	36512+200n 36513+200n	1036512+200n 1036513+200n

*1 Cam axis cycle units (Page 126 Units for the output axis)

*2 Output axis position units (Page 126 Units for the output axis)

[Pr.460] Setting method of current value per cycle after main shaft gear

Select the setting method of "[Md.401] Current value per cycle after main shaft gear" when starting synchronous control.

Setting value	Details
0: Previous value	The current value per cycle after main shaft gear from the last synchronous control session is stored.
1: Initial setting value of current value per cycle after main shaft gear	The value set in "[Pr.465] Current value per cycle after main shaft gear (Initial setting)" is stored.
2: Calculate from input axis	The value calculated based on the current value after composite main shaft gear is stored.

[Pr.461] Setting method of current value per cycle after auxiliary shaft gear

Select the setting method of "[Md.402] Current value per cycle after auxiliary shaft gear" when starting synchronous control.

Setting value	Details
0: Previous value	The current value per cycle after auxiliary shaft gear from the last synchronous control session is stored.
1: Initial setting value of current value per cycle after auxiliary shaft gear	The value set in "[Pr.466] Current value per cycle after auxiliary shaft gear (Initial setting)" is stored.
2: Calculate from input axis	The value calculated based on the auxiliary shaft current value is stored.

[Pr.462] Cam axis position restoration object

Select the object to be restored from "Cam axis current value per cycle", "Cam reference position" or "Cam axis feed current value" when starting synchronous control.

Setting value	Details
0: Cam axis current value per cycle restoration	Restore the cam axis current value per cycle from "Cam reference position" and "Cam axis feed current value".
1: Cam reference position restoration	Restore the cam reference position from "Cam axis current value per cycle" and "Cam axis feed current value".
2: Cam axis feed current value restoration	Restore the cam axis feed current value from "Cam axis current value per cycle" and "Cam reference position".

[Pr.463] Setting method of cam reference position

Select the method for the cam reference position to be restored when "[Pr.462] Cam axis position restoration object" is set to "0: Cam axis current value per cycle restoration" or "2: Cam axis feed current value restoration".

Setting value	Details
0: Previous value	The cam reference position from the last synchronous control session is stored. The feed current value is stored when the cam reference position from the last synchronous control session is not saved.
1: Initial setting value of cam reference position	The value set in "[Pr.467] Cam reference position (Initial setting)" is stored.
2: Feed current value	The value set in "[Md.20] Feed current value" is stored.

[Pr.464] Setting method of cam axis current value per cycle

Select the method for the cam axis current value per cycle to be restored when "[Pr.462] Cam axis position restoration object" is set to "1: Cam reference position restoration" or "2: Cam axis feed current value restoration".

Setting value	Details
0: Previous value	The cam axis current value per cycle from the last synchronous control session is stored as is.
1: Initial setting value of cam axis current value per cycle	The value set in "[Pr.468] Cam axis current value per cycle (Initial setting)" is stored.
2: Current value per cycle after main shaft gear	The current value per cycle after main shaft gear is stored.
3: Current value per cycle after auxiliary shaft gear	The current value per cycle after auxiliary shaft gear is stored.

[Pr.465] Current value per cycle after main shaft gear (Initial setting)

Set the initial setting value of the current value per cycle after main shaft gear when "[Pr.460] Setting method of current value per cycle after main shaft gear" is set to "1: Current value per cycle after main shaft gear (Initial setting)".

The unit settings are in cam axis cycle units ( Page 126 Units for the output axis). Set within the range from 0 to (Cam axis length per cycle - 1).

[Pr.466] Current value per cycle after auxiliary shaft gear (Initial setting)

Set the initial setting value of the current value per cycle after auxiliary shaft gear when "[Pr.461] Setting method of current value per cycle after auxiliary shaft gear" is set to "1: Current value per cycle after auxiliary shaft gear (Initial setting)".

The unit settings are in cam axis cycle units ( Page 126 Units for the output axis). Set within the range from 0 to (Cam axis length per cycle - 1).

[Pr.467] Cam reference position (Initial setting)

Set the initial setting value of the cam reference position in output axis position units ( Page 126 Units for the output axis) when "[Pr.463] Setting method of cam reference position" is set to "1: Cam reference position (Initial setting)".

[Pr.468] Cam axis current value per cycle (Initial setting)

Set a value according to the setting for "[Pr.462] Cam axis position restoration object".

The unit settings are in cam axis cycle units ( Page 126 Units for the output axis). Set within the range from 0 to (Cam axis length per cycle - 1).

[Pr.462] Cam axis position restoration object	Setting value
0: Cam axis current value per cycle restoration	Set the starting point for search processing to restore the cam axis current value per cycle. Set to restore the position on the return path in two-way cam pattern operation. Refer to the following for details on search processing.  Page 150 Cam axis current value per cycle restoration
1: Cam reference position restoration	Set the initial setting value for the cam axis current value per cycle when "[Pr.464] Setting method of cam axis current value per cycle" is set to "1: Cam axis current value per cycle (Initial setting)".
2: Cam axis feed current value restoration	

5.3 Cam Axis Position Restoration Method

Cam axis current value per cycle restoration

If "[Pr.462] Cam axis position restoration object" is set to "0: Cam axis current value per cycle restoration" when starting synchronous control, the cam axis current value per cycle is restored based on the cam reference position and the cam axis feed current value.

Select the method for the cam reference position to be restored. The feed current value when starting synchronous control is used as the cam axis feed current value.

The cam axis current value per cycle is restored by searching for the corresponding value from the beginning to the end of the cam pattern. Set the starting point from where to search the cam pattern in "[Pr.468] Cam axis current value per cycle (Initial setting)". (It is also possible to search the return path in a two-way cam pattern operation.)

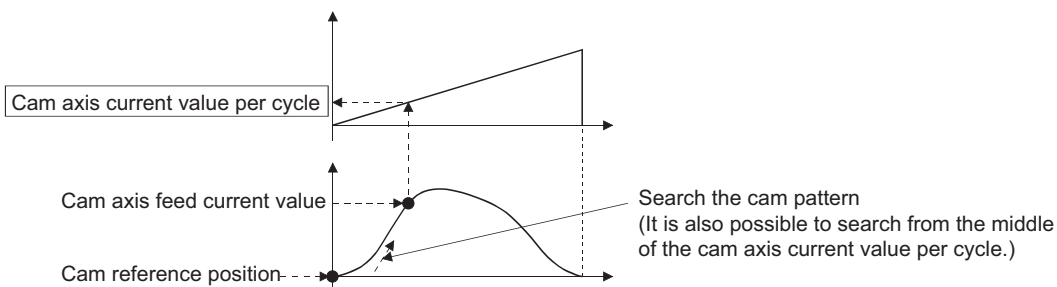
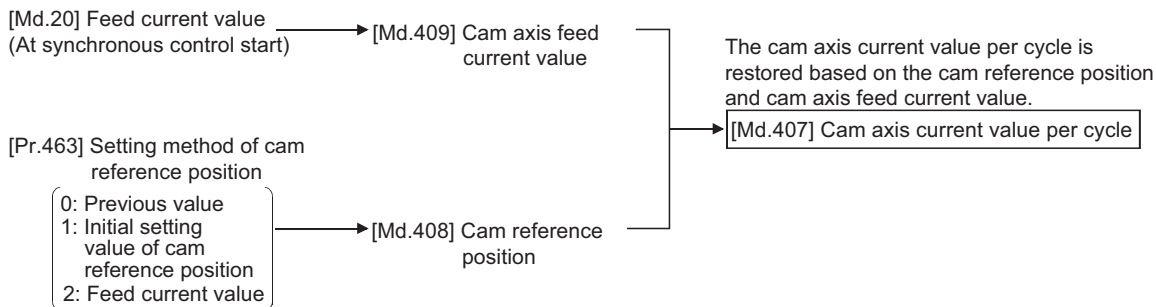

Restriction

- With two-way cam pattern operation, if the corresponding cam axis current value per cycle is not found, the error "Cam axis current value per cycle restoration disable" (error code: 1C28H) will occur and synchronous control will not be started.
- When starting synchronous control, the feed current value may change slightly from its original position at starting synchronous control. This is due to the readjustment of the position based on the restored cam axis current value per cycle. This does not result in the position mismatch.
- With a feed operation cam pattern, if the corresponding cam axis current value per cycle is not found on the first cycle, the cam reference position is changed automatically and the pattern is searched again.
- If the cam resolution is large, search processing may take a long time when starting synchronous control. (Cam resolution 256: Up to 0.4 ms [RD77MS], Up to 0.5ms [RD77GF], Cam resolution 32768: Up to 26 ms)

Cam axis current value per cycle restoration operation

■With a two-way cam pattern operation

- Search from "Cam axis current value per cycle = 0". (Cam data starting point = 0)

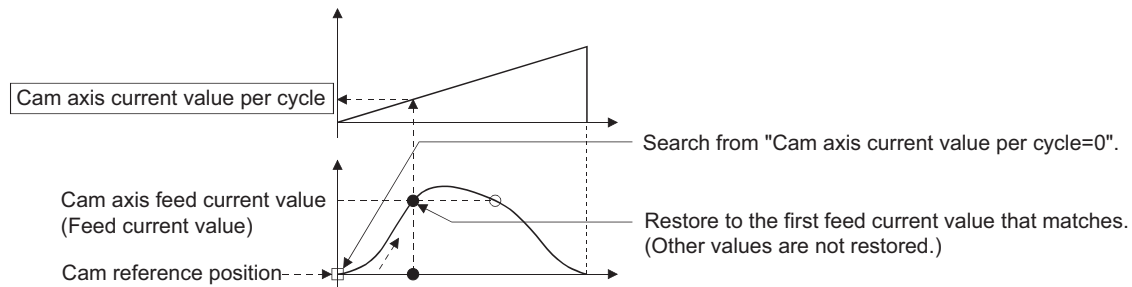

- Search from a value in the middle of the cam axis current value per cycle. (Cam data starting point $\neq 0$)

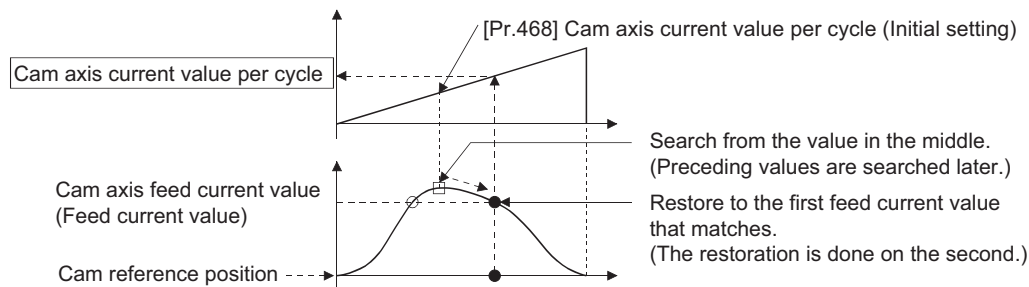

- Search from a value in the middle of the cam axis current value per cycle. (Cam data starting point $\neq 0$)

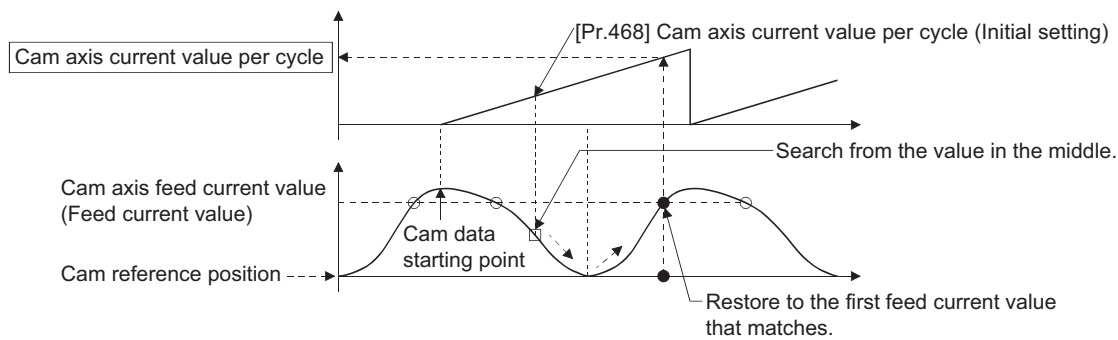

- The search fails.

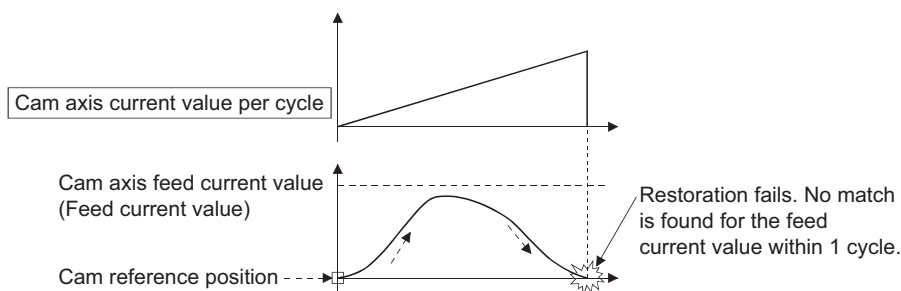

■With a feed operation cam pattern

- Search from "Cam axis current value per cycle = 0". (Cam data starting point = 0)

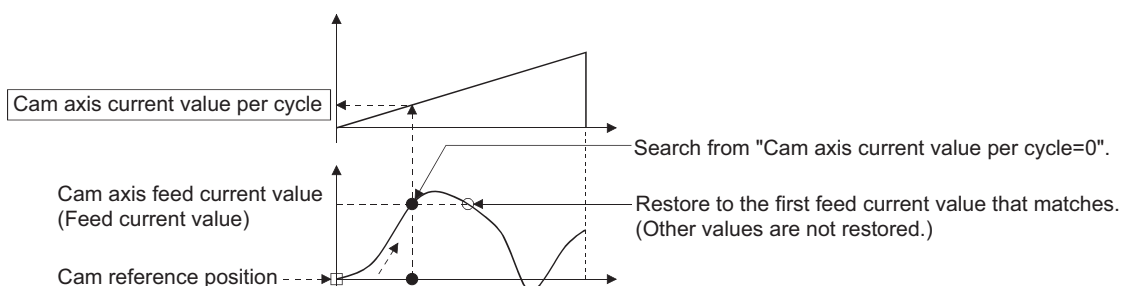

- Search from a value in the middle of the cam axis current value per cycle. (Cam data starting point = 0)

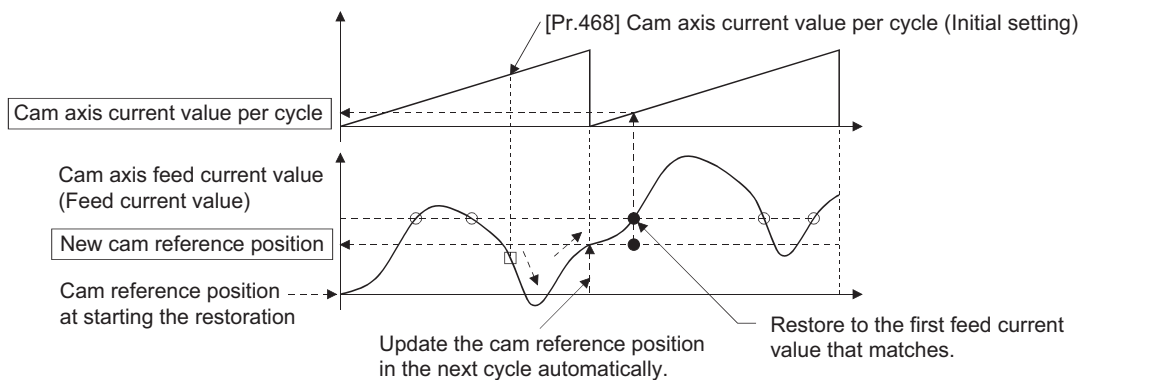

- Search from a value in the middle of the cam axis current value per cycle. (Cam data starting point ≠ 0)

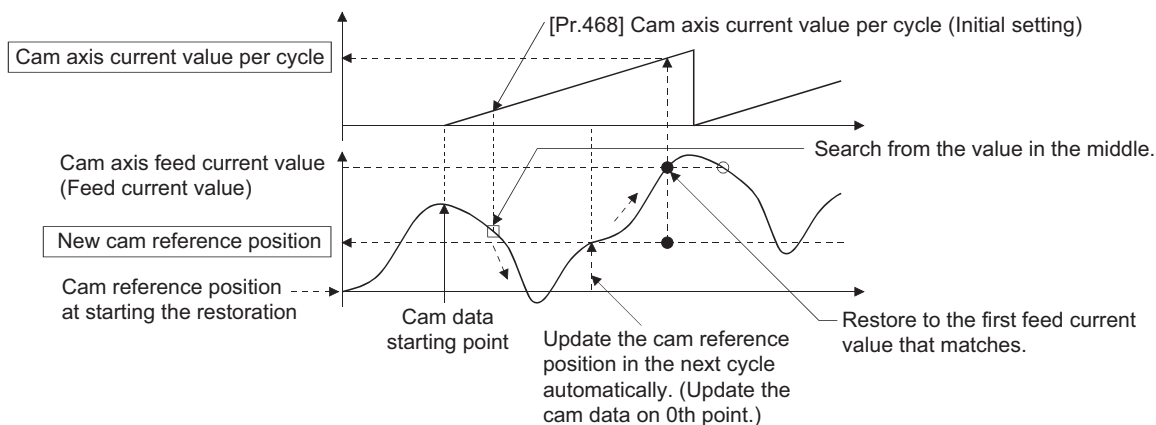

- The first search is fails and a search begins for the second time.

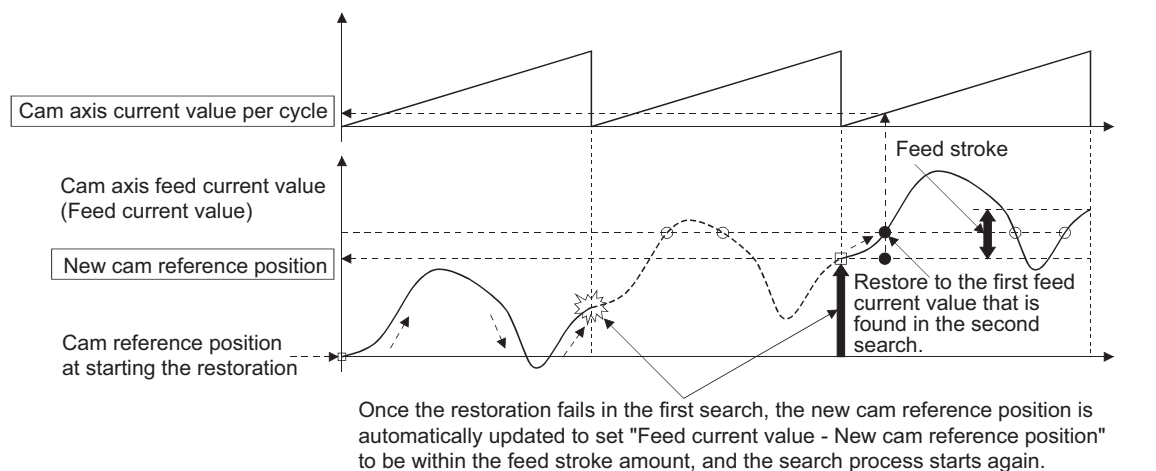

Point

If the first search fails, a second search may not be processed on the next cycle for a cam pattern with a feed stroke that is smaller than 100% of the stroke as above.

The intended cam axis current value per cycle can be found in the first search, by setting or positioning the cam reference position in advance.

Example

The following shows an example of restarting the cam (a cam similar to a cam with a linear feed where two identical positioning points do not exist on the cam) from the feed current value after a forced stop, when the forced stop has stopped operation.

If the following settings are used in a two-way cam or a cam where identical positioning points exist on the same cam, similar to the cam axis current value per cycle restoration operation (☞ Page 151 Cam axis current value per cycle restoration operation), the first matching feed current value (outward route) is restored, therefore restoration may start from an unintended cam pattern position. To avoid restoring the first matching feed current value, use cam axis feed current value restoration (☞ Page 156 Cam axis feed current value restoration).

Setting item	Setting value
[Pr.439] Cam axis length per cycle	1000 [pulse]
[Pr.441] Cam stroke amount	200 [pulse]
[Pr.462] Cam axis position restoration object	0: Cam axis current value per cycle restoration
[Pr.463] Setting method of cam reference position	1: Initial setting value of cam reference position
[Pr.464] Setting method of cam axis current value per cycle	0: Previous value
[Pr.467] Cam reference position (Initial setting)	0 [pulse]
[Pr.468] Cam axis current value per cycle (Initial setting)	0 [pulse]

• Advanced synchronous control operation

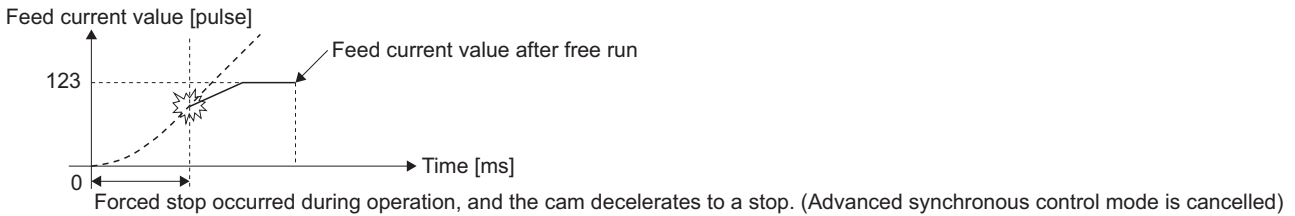

• Restore operation at restart of advanced synchronous control

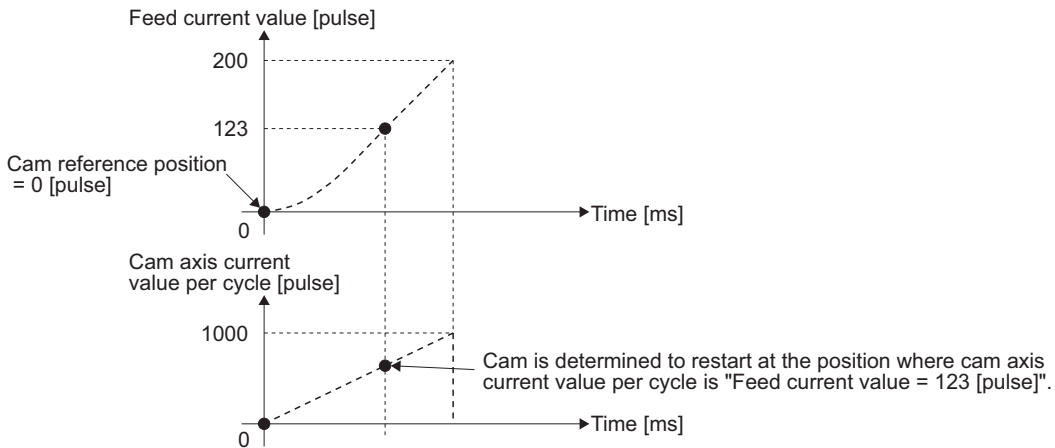

• Cam operation

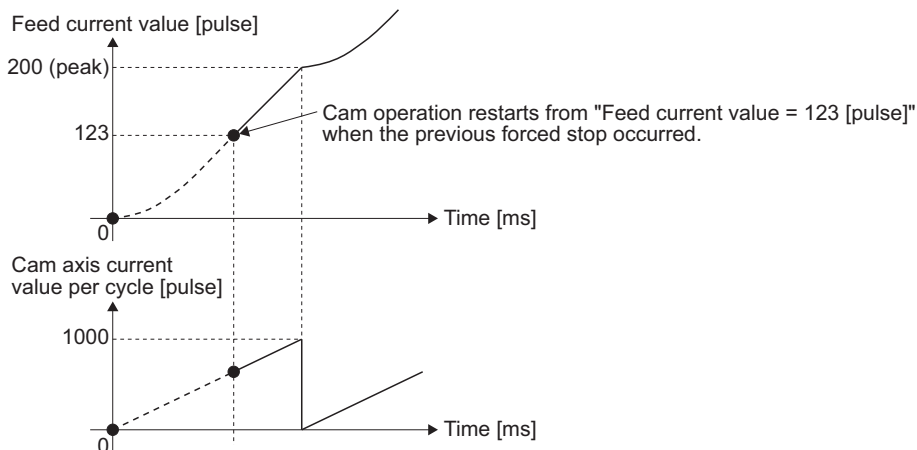

Cam reference position restoration

If "[Pr.462] Cam axis position restoration object" is set to "1: cam reference position restoration" when starting synchronous control, the cam reference position is restored based on the cam axis current value per cycle and the cam axis feed current value.

Select the method for the cam axis current value per cycle to be restored. The feed current value when starting synchronous control is used as the cam axis feed current value.

[Pr.464] Setting method of cam axis current value per cycle

- 0: Previous value
- 1: Initial setting value of cam axis current value per cycle
- 2: Current value per cycle after main shaft gear
- 3: Current value per cycle after auxiliary shaft gear

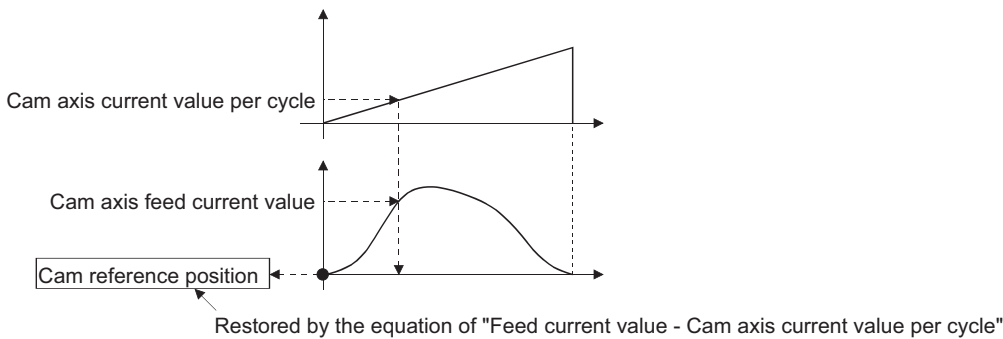
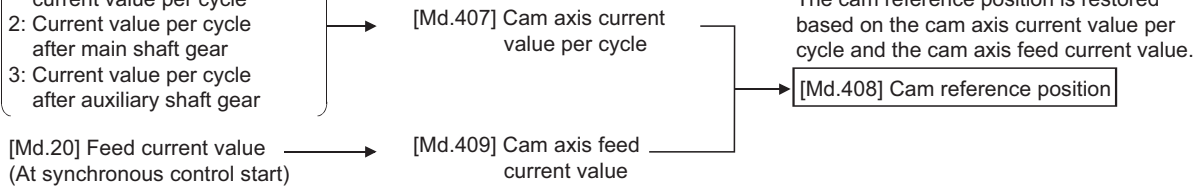

Example

The following shows an example of starting operation from a position of "cam axis current value per cycle=0" by restoring the cam reference position when starting from "feed current value=0 [pulse]", in the cam when the cam data starting point is not 0.

Setting item	Setting value
[Pr.439] Cam axis length per cycle	1000 [pulse]
[Pr.441] Cam stroke amount	200 [pulse]
[Pr.462] Cam axis position restoration object	1: Cam reference position restoration
[Pr.463] Setting method of cam reference position	None
[Pr.464] Setting method of cam axis current value per cycle	1: Initial setting value of cam axis current value per cycle
[Pr.467] Cam reference position (Initial setting)	None
[Pr.468] Cam axis current value per cycle (Initial setting)	0 [pulse]

- Operation before starting advanced synchronous control

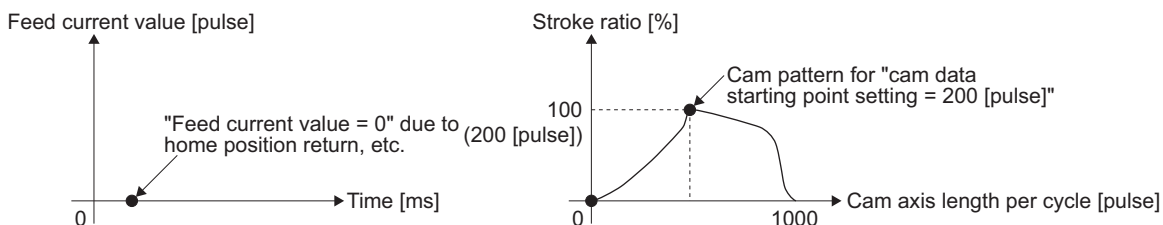

- Restore operation at start of advanced synchronous control

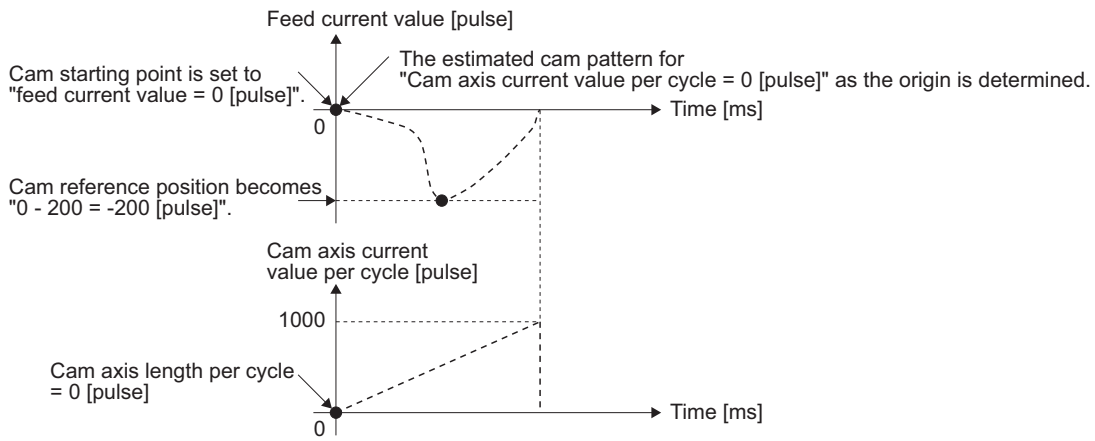

- Cam operation

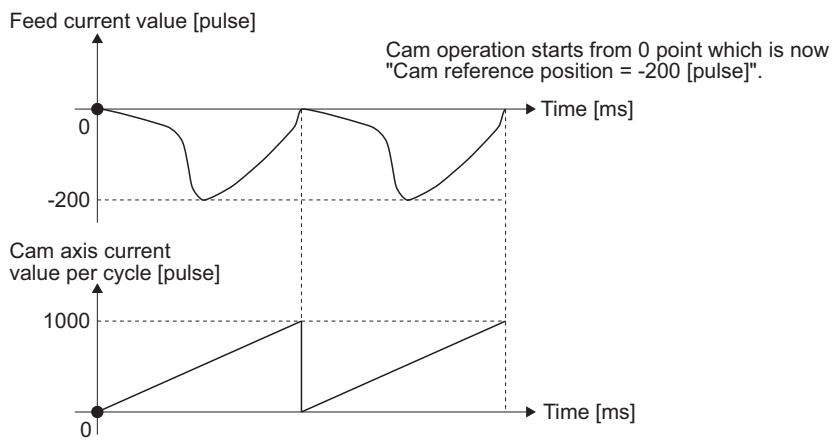

Cam axis feed current value restoration

If "[Pr.462] Cam axis position restoration object" is set to "2: Cam axis feed current value restoration" when starting synchronous control, the cam axis feed current value is restored based on the cam axis current value per cycle and the cam reference position.

Select the method for the cam axis current value per cycle and the method for the cam reference position to be restored.

[Pr.464] Setting method of cam axis current value per cycle

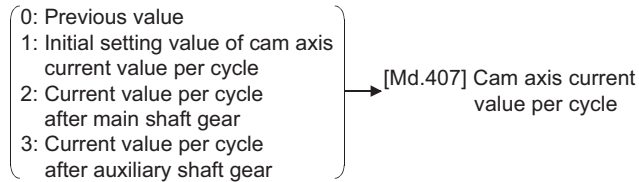

[Pr.463] Setting method of cam reference position

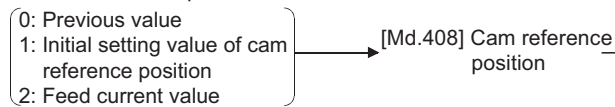

The cam axis feed current value is restored based on the cam axis current value per cycle and the cam reference position.

[Md.409] Cam axis feed current value

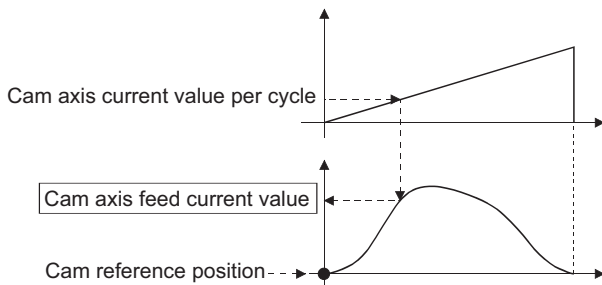

Restriction

The cam axis feed current value moves to its restored value just after starting synchronous control when the cam axis feed current value to be restored is different from the feed current value at synchronous control start. [RD77MS]

If the difference is larger than "In-position width (PA10)" of servo amplifier in pulse command units, the error "Cam axis feed current value restoration disable" (error code: 1C29H) will occur and synchronous control cannot be started.

Note that, if the setting value of "In-position width" is large, a rapid operation may occur.

[RD77GF]

If the difference is larger than "1600 [pulse]" in pulse command units, the error "Cam axis feed current value restoration disable" (error code: 1C29H) will occur and synchronous control cannot be started.

Point

With cam axis feed current value restoration, calculate the cam axis feed current value with the cam position calculation function (Page 162 Cam Position Calculation Function) or with synchronous control analysis mode (Page 159 Synchronous Control Analysis Mode) before starting synchronous control. Then start synchronous control after positioning to the correct cam axis feed current value.

Example

The following shows an example of starting a cam pattern from the zero point of the cam axis current value per cycle with the current feed current value position as the origin when returning to a specified point, or home position return is completed after a forced stop.

Setting item	Setting value
[Pr.439] Cam axis length per cycle	1000 [pulse]
[Pr.441] Cam stroke amount	200 [pulse]
[Pr.462] Cam axis position restoration object	2: Cam axis feed current value restoration
[Pr.463] Setting method of cam reference position	2: Feed current value
[Pr.464] Setting method of cam axis current value per cycle	1: Initial setting value of cam axis current value per cycle
[Pr.467] Cam reference position (Initial setting)	None
[Pr.468] Cam axis current value per cycle (Initial setting)	0 [pulse]

- Move to advanced synchronous control starting point

Feed current value [pulse]

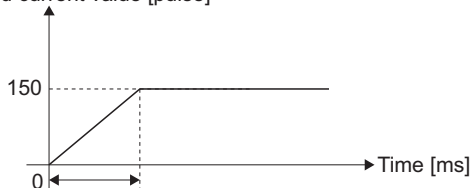

Move to the position of 150 [pulse] by return to cam starting position, or by home position return.

- Restore operation

Feed current value [pulse]

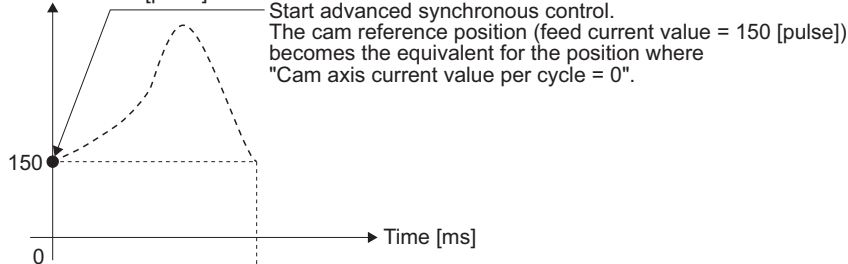

Cam axis current value per cycle [pulse]

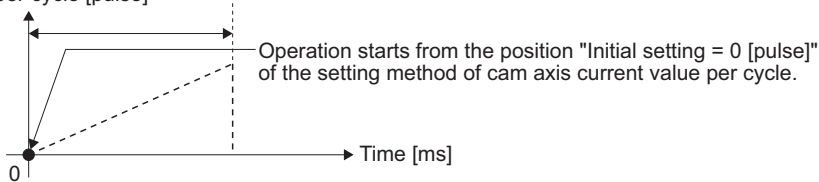

• Cam operation

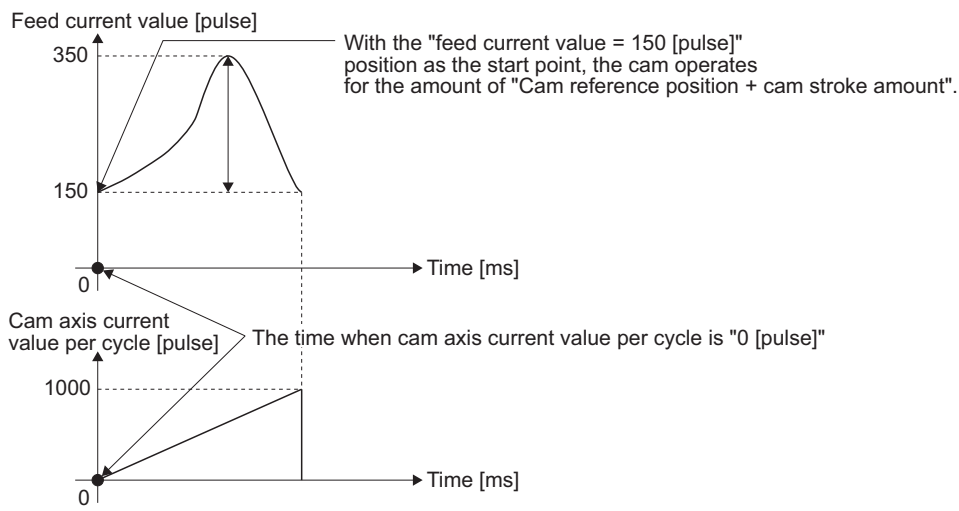

5.4 Synchronous Control Analysis Mode

With synchronous control analysis mode, advanced synchronous control parameters are only analyzed when there is a command to start synchronous control. This mode is used to confirm the synchronous positions of the output axes in order to align axes with position control before starting synchronous control.

If the target axis bit is ON in "[Cd.381] Synchronous control analysis mode" when starting synchronous control (turning the target axis bit from OFF to ON for "[Cd.380] Synchronous control start"), operation enters synchronous control analysis mode.

When the synchronization position analysis is completed, the synchronous control monitor data ([Md.400] to [Md.425]) is updated, and the target axis bit in "[Cd.380] Synchronous control start" turns OFF.

The busy signal is not turned ON during synchronous control analysis mode.

When starting synchronous control with synchronous control analysis mode, the following error does not occur.

- Cam axis feed current value restoration disable (error code: 1C29H)

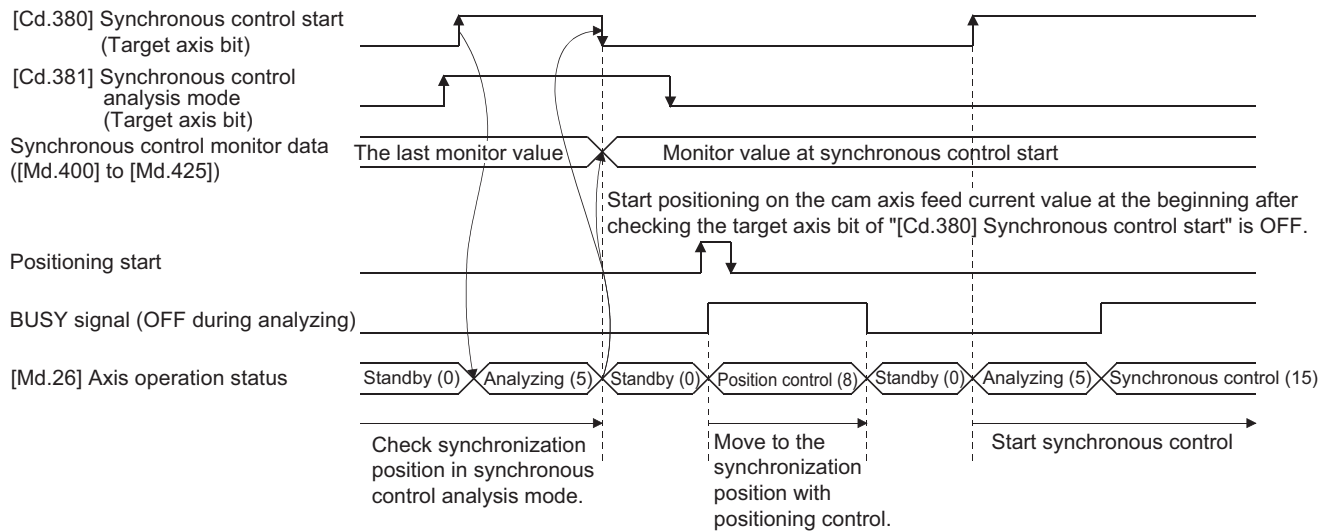

Synchronous control system control data

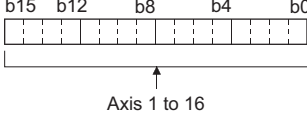
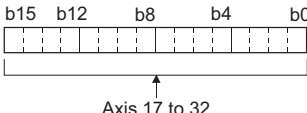
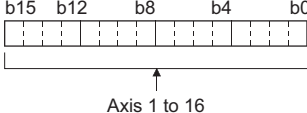
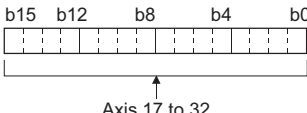
Setting item	Setting details	Setting value	Default value	Buffer memory address	
				Axis 1 to axis 16	Axis 17 to axis 32
[Cd.380] Synchronous control start	<ul style="list-style-type: none"> Synchronous control begins if the target axis bit is turned ON. Synchronous control ends if the bit is turned OFF during synchronous control. <p>Fetch cycle: <u>Operation cycle</u></p>	<p>■ Set the target axis in bit. Set with the following two buffer memory addresses.</p> <ul style="list-style-type: none"> Buffer memory address: 36320 (bit0: axis 1 to bit15: axis 16^{*1}) Buffer memory address: 1036320 (bit0: axis 17 to bit15: axis 32^{*1}) <p>Buffer memory address: 36320</p>  <p>Buffer memory address: 1036320</p>  <p>OFF: Synchronous control end ON: Synchronous control start</p>	0	36320	1036320
[Cd.381] Synchronous control analysis mode	<ul style="list-style-type: none"> If the target axis bit is turned ON and synchronous control is started, the analysis is only executed and the control does not start. <p>Fetch cycle: <u>At start of synchronous control</u></p>	<p>■ Set the target axis in bit. Set with the following two buffer memory addresses.</p> <ul style="list-style-type: none"> Buffer memory address: 36322 (bit0: axis 1 to bit15: axis 16^{*1}) Buffer memory address: 1036322 (bit0: axis 17 to bit15: axis 32^{*1}) <p>Buffer memory address: 36322</p>  <p>Buffer memory address: 1036322</p>  <p>OFF: Synchronous control analysis mode OFF ON: Synchronous control analysis mode ON</p>	0	36322	1036322

*1 The range from axis 1 to 2 is valid in the 2-axis module, from axis 1 to 4 is valid in the 4-axis module, from axis 1 to 8 is valid in the 8-axis module, from axis 1 to 16 is valid in the 16-axis module, and from axis 1 to 32 is valid in the 32-axis module.

Example

The following shows a procedure of aligning the synchronous position of an output axis that references the input axis.

1. Set the following values in the synchronous control initial position parameters.

Setting item	Setting value
[Pr.460] Setting method of current value per cycle after main shaft gear	2: Calculate from input axis
[Pr.462] Cam axis position restoration object	2: Cam axis feed current value restoration
[Pr.463] Setting method of cam reference position	0: Previous value
[Pr.464] Setting method of cam axis current value per cycle	2: Current value per cycle after main shaft gear

2. Turn ON the target axis bit of "[Cd.381] Synchronous control analysis mode", and then turn the target axis bit from OFF to ON in "[Cd.380] Synchronous control start" to start the synchronous control analysis mode.
3. Verify the target axis bit is OFF for "[Cd.380] Synchronous control start", and execute positioning for the output axis to be updated to "[Md.409] Cam axis feed current value".
4. Turn OFF the target axis bit of "[Cd.381] Synchronous control analysis mode", and then turn the target axis bit from OFF to ON in "[Cd.380] Synchronous control start" to start synchronous control.

5.5 Cam Position Calculation Function

The cam position is calculated by the program with this function. This function can be used to calculate the cam position for the synchronous control initial position before starting synchronous control.

Example

The following shows the procedure for synchronous position alignment, in a synchronous system where cam axes 2 and 3 are synchronized with the cam axis current value per cycle of axis 1.

1. Calculate the cam axis current value per cycle using this function based on the feed current value and the cam reference position of axis 1.
2. Calculate the cam axis feed current value of axis 2 with this function based on the cam axis current value per cycle that was calculated in 1).
3. Calculate the cam axis feed current value of axis 3 with this function based on the cam axis current value per cycle that was calculated in 1).
4. Execute positioning on axis 2 to the cam axis feed current value which was calculated in 2), and also on axis 3 to the cam axis feed current value which was calculated in 3).
5. Start synchronous control on axis 1, 2 and 3 with the feed current value restoration mode. Use the cam axis current value per cycle that was calculated in 1) for the cam axis current value per cycle (Initial setting).

Cam position calculation control data

Setting item	Setting details	Setting value	Default value	Buffer memory address
[Cd.612] Cam position calculation request	<ul style="list-style-type: none"> Set the cam position calculation request. The Simple Motion module resets the value to "0" automatically after completion of the cam position calculation. Fetch cycle: Main cycle*1	■Set in decimal. 1: Cam axis feed current value calculation request 2: Cam axis current value per cycle calculation request	0	53780
[Cd.613] Cam position calculation: Cam No.	<ul style="list-style-type: none"> Set the cam No. for the cam position calculation. Fetch cycle: At requesting cam position calculation	■Set in decimal. 0 to 256 [RD77MS] 0 to 1024 [RD77GF]	0	53781
[Cd.614] Cam position calculation: Stroke amount	<ul style="list-style-type: none"> Set the cam stroke amount for the cam position calculation. Fetch cycle: At requesting cam position calculation	■Set in decimal. -2147483648 to 2147483647 [Output axis position units*2]	0	53782 53783
[Cd.615] Cam position calculation: Cam axis length per cycle	<ul style="list-style-type: none"> Set the cam axis length per cycle for the cam position calculation. Fetch cycle: At requesting cam position calculation	■Set in decimal. 1 to 2147483647 [Cam axis cycle units*3]	0	53784 53785
[Cd.616] Cam position calculation: Cam reference position	<ul style="list-style-type: none"> Set the cam reference position for the cam position calculation. Fetch cycle: At requesting cam position calculation	■Set in decimal. -2147483648 to 2147483647 [Output axis position units*2]	0	53786 53787
[Cd.617] Cam position calculation: Cam axis current value per cycle	<ul style="list-style-type: none"> Set the cam axis current value per cycle for the cam position calculation. Fetch cycle: At requesting cam position calculation	■Set in decimal. 0 to (Cam axis length per cycle) [Cam axis cycle units*3]	0	53788 53789
[Cd.618] Cam position calculation: Cam axis feed current value	<ul style="list-style-type: none"> Set the cam axis feed current value for the cam position calculation. (Set when calculating the cam axis current value per cycle.) Fetch cycle: At requesting cam position calculation	■Set in decimal. -2147483648 to 2147483647 [Output axis position units*2]	0	53790 53791

*1 With the exception of positioning control, main cycle processing is executed during the next available time. It changes by status of axis start.

*2 Output axis position units( Page 126 Units for the output axis)

*3 Cam axis cycle units( Page 126 Units for the output axis)

[Cd.612] Cam position calculation request

Set the following commands to calculate the cam position.

Setting value	Details
1	Cam axis feed current value calculation request
2	Cam axis current value per cycle calculation request

The result is stored in "[Md.600] Cam position calculation result" and the setting value is reset to "0" automatically after completion of cam position calculation.

If warnings occur when requesting the cam position calculation, the warning No. is stored in "[Md.24] Axis warning No." of axis 1 and the setting value is reset to "0" automatically.

When a value other than the request command values listed above is set, this calculation does not get executed and the setting value is reset to "0" automatically.

[Cd.613] Cam position calculation: Cam No.

Set the cam No. for the cam position calculation. If 0 is set for the cam No., the cam position is calculated as a linear cam.

[Cd.614] Cam position calculation: Stroke amount

Set the cam stroke amount for the cam position calculation.

[Cd.615] Cam position calculation: Cam axis length per cycle

Set the cam axis length per cycle for the cam position calculation.

[Cd.616] Cam position calculation: Cam reference position

Set the cam reference position for the cam position calculation.

[Cd.617] Cam position calculation: Cam axis current value per cycle

Set the cam axis current value per cycle for the cam position calculation when calculating the cam axis feed current value.

Set the cam axis current value per cycle as the starting point to search when calculating the cam axis current value per cycle and the cam position.

[Cd.618] Cam position calculation: Cam axis feed current value

Set the cam axis feed current value for the cam position calculation when calculating the cam axis current value per cycle.

This is not used when calculating the cam axis feed current value.

Cam position calculation monitor data

Monitor item	Storage details	Monitor value	Buffer memory address
[Md.600] Cam position calculation result	<ul style="list-style-type: none"> The result of the cam position calculation is stored. Refresh cycle: At cam position calculation completion	■Monitoring is carried out in decimal. <ul style="list-style-type: none"> When calculating the cam axis feed current value: -2147483648 to 2147483647 [Output axis position units^{*1}] When calculating the cam axis current value per cycle: 0 to (Cam axis length per cycle - 1) [Cam axis cycle units^{*2}] 	53800 53801

*1 Output axis position units (☞ Page 126 Units for the output axis)

*2 Cam axis cycle units(☞ Page 126 Units for the output axis)

[Md.600] Cam position calculation result

The result of the cam position calculation is stored.

Cam position calculation	Storage details
When calculating the cam axis feed current value	Calculated value of the cam axis feed current value is stored.
When calculating the cam axis current value per cycle	Calculated value of the cam axis current value per cycle is stored. The cam reference position is not updated automatically by the cam position calculation function.

Search for the cam axis current value per cycle

When calculating the cam axis current value per cycle using cam data, the position corresponding to "[Cd.618] Cam position calculation: Cam axis feed current value" is searched using cam data based on the position specified by "[Cd.617] Cam position calculation: Cam axis current value per cycle".

The following shows the order of the search for "[Cd.618] Cam position calculation: Cam axis feed current value".

■Stroke ratio data format

When "the nth point of cam data \leq [Cd.617] Cam position calculation: Cam axis current value per cycle < the n + 1st point of cam data", the position corresponding to "[Cd.618] Cam position calculation: Cam axis feed current value" is searched from the nth point of cam data.

If "[Cd.617] Cam position calculation: Cam axis current value per cycle" is in the middle of the cam data and the corresponding position is not found until the last point of the cam data, return to the 0th point and search until the search starting point.

If the corresponding position is not found even though the whole area of the cam data has been searched, the warning "Cam position calculation cam axis 1 cycle current value calculation disable" (warning code: 0C64H) will occur in reciprocated cam pattern.

For the feed cam, calculates "[Cd.618] Cam position calculation: Cam axis feed current value" by the stroke difference and searches again from the 0th point to the whole range. If the corresponding position is not found even though the search process starts again, the warning "Cam position calculation cam axis 1 cycle current value calculation disable" (warning code: 0C64H) will occur.

Ex.

When "[Cd.617] Cam position calculation: Cam axis current value per cycle" is corresponding to the 0th point of cam data

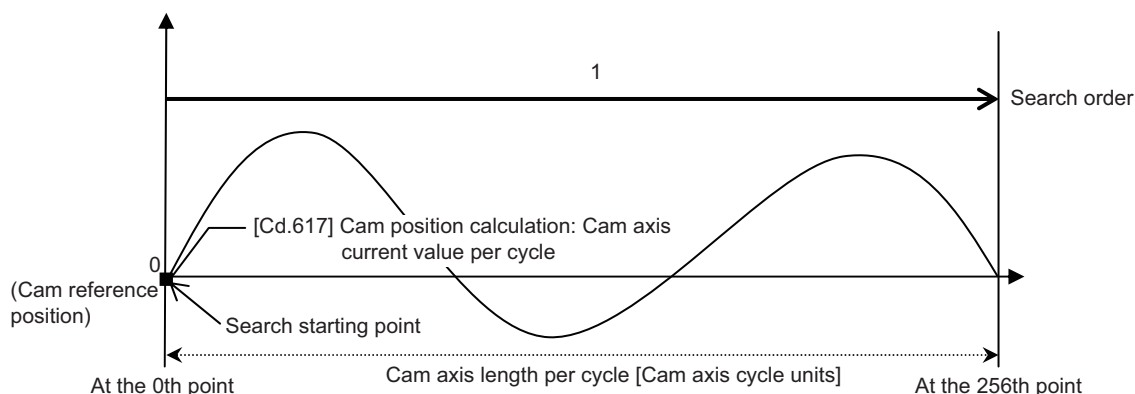

- Searches until between the 255th point and the 256th point (last point) in order of the cam data between the 0th point and the 1st point and between the 1st point and the 2nd point.

Ex.

When "[Cd.617] Cam position calculation: Cam axis current value per cycle" is corresponding to the 128th point of cam data

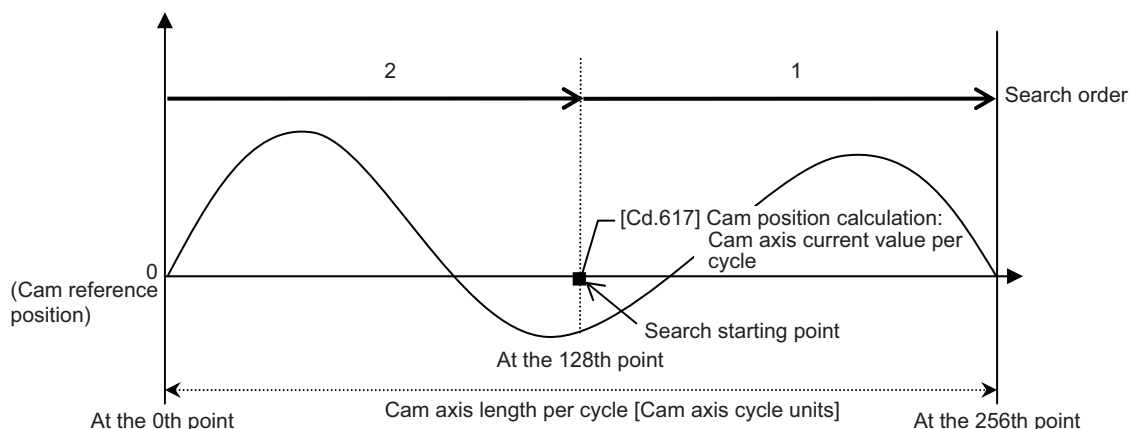

- Searches until between the 255th point and the 256th point (last point) in order of the cam data between the 128th point and the 129th point and between the 130th point and the 131th point.
- If the corresponding position is not found until the last point of the cam data, searches from the 0th point of the cam data.
- Searches until between the 127th point and the 128th point in order of the cam data between the 0th point and the 1st point and between the 1st point and the 2nd point.

Coordinate data format

(1) The range before the 1st point of cam data

When the 1st point of the cam data is larger than 0 and "[Cd.617] Cam position calculation: Cam axis current value per cycle < the 1st point of cam data", the position corresponding to "[Cd.618] Cam position calculation: Cam axis feed current value" is searched from the range before the 1st point of the cam data.

If the corresponding position is not found in the range of (1), searches in the range of (2). If the corresponding position is not found in the range of (2) either, searches in the range of (3).

If the corresponding position is not found even though the range of (1) to (3) has been searched, the warning "Cam position calculation cam axis 1 cycle current value calculation disable" (warning code: 0C64H) will occur in reciprocated cam pattern.

For the feed cam, calculates "[Cd.618] Cam position calculation: Cam axis feed current value" by the stroke difference and searches again from the 0th point to the whole range. If the corresponding position is not found even though the search process starts again, the warning "Cam position calculation cam axis 1 cycle current value calculation disable" (warning code: 0C64H) will occur.

Ex.

When "[Cd.617] Cam position calculation: Cam axis current value per cycle" is set before the 1st point of cam data

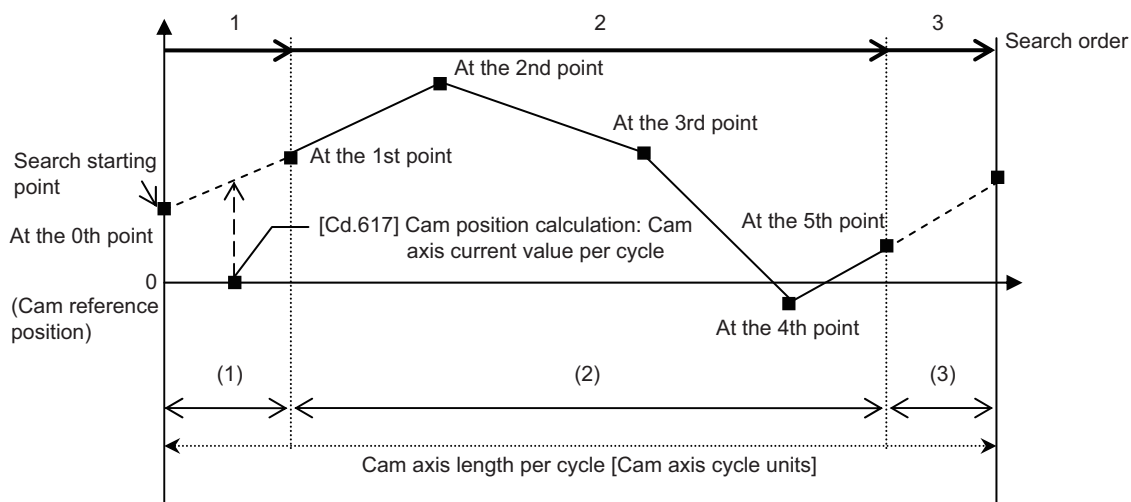

- Searches from the range of (1).
- If the corresponding position is not found in the range of (1), searches from the 1st point of the cam data in the range of (2).

(2) The range within the cam data

When "[Cd.617] Cam position calculation: Cam axis current value per cycle < the last point of cam data", the position corresponding to "[Cd.618] Cam position calculation: Cam axis feed current value" is searched from the range of the cam data.

When "the nth point of cam data \leq [Cd.617] Cam position calculation: Cam axis current value per cycle < the n + 1st point of cam data", the position corresponding to "[Cd.618] Cam position calculation: Cam axis feed current value" is searched from the nth point of cam data.

If "[Cd.617] Cam position calculation: Cam axis current value per cycle" is in the middle of the cam data and the corresponding position is not found until the last point of the cam data, returns to the 1st point and searches until the search starting point.

If the corresponding position is not found in the range of (2), searches in the range of (3).

If the corresponding position is not found even though the range of (2) and (3) has been searched, the warning "Cam position calculation cam axis 1 cycle current value calculation disable" (warning code: 0C64H) will occur in reciprocated cam pattern.

For the feed cam, calculates "[Cd.618] Cam position calculation: Cam axis feed current value" by the stroke difference and searches again from the 0th point to the whole range. If the corresponding position is not found even though the search process starts again, the warning "Cam position calculation cam axis 1 cycle current value calculation disable" (warning code: 0C64H) will occur.

Ex.

When "[Cd.617] Cam position calculation: Cam axis current value per cycle" is corresponding to the 1st point of cam data

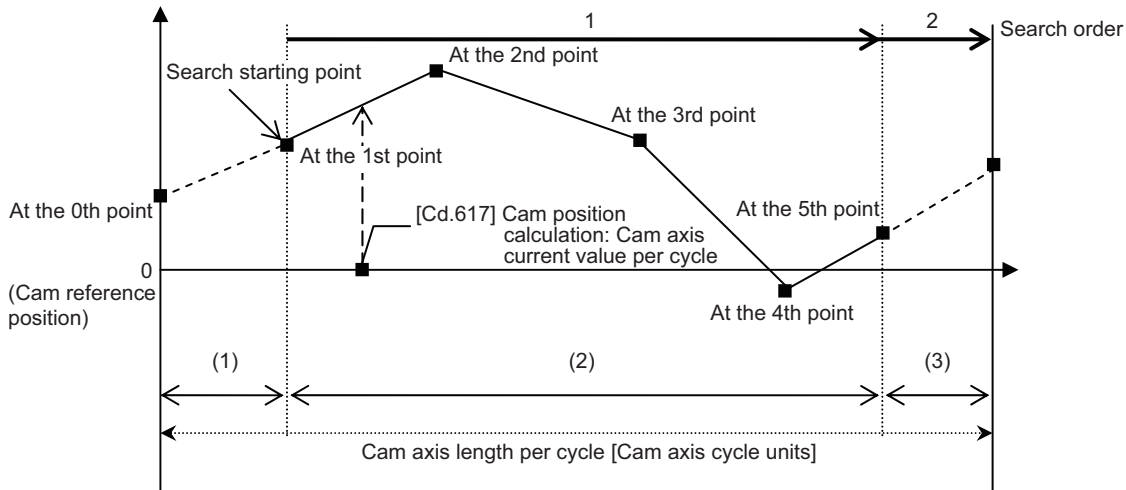

- Searches until between the 4th point and the 5th point (last point) in order of the cam data between the 1st point and the 2nd point and between the 2nd point and the 3rd point.
- If the corresponding position is not found until the last point of the cam data, searches from the range of (3).

Ex.

When "[Cd.617] Cam position calculation: Cam axis current value per cycle" is corresponding to the 3rd point of cam data

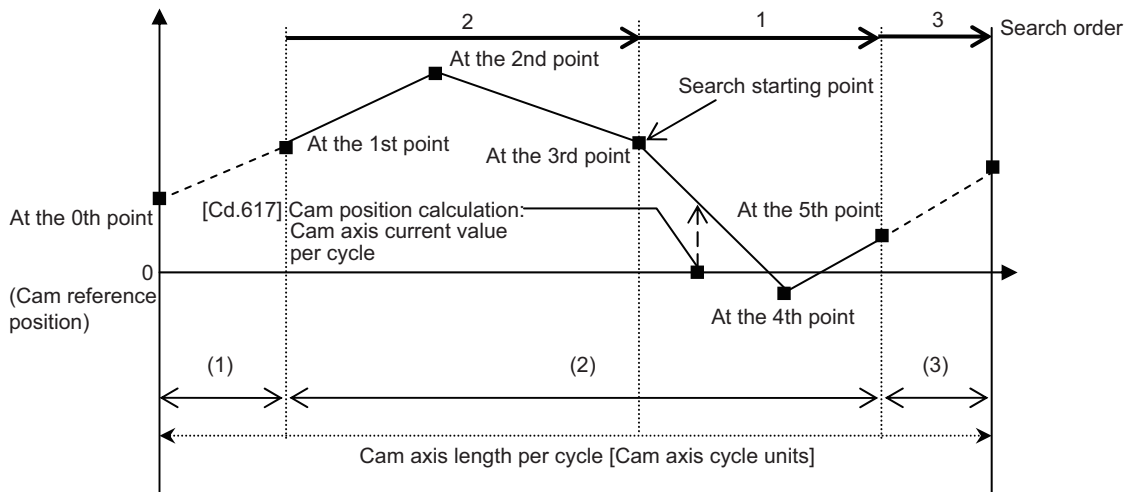

- Searches in order of the cam data between the 3rd point and the 4th point and between the 4th point and the 5th point (last point).
- If the corresponding position is not found until the last point of the cam data, searches from the 1st point of the cam data.
- If the corresponding position is not found in the cam data between the 1st point and the 2nd point and between the 2nd point and the 3rd point, searches from the range of (3).

(3) The range from the last point of cam data to the cam axis length per cycle

When "the last point of cam data \leq [Cd.617] Cam position calculation: Cam axis current value per cycle < cam axis length per cycle", the position corresponding to "[Cd.618] Cam position calculation: Cam axis feed current value" is searched from the last point of the cam data or later.

If the corresponding position is not found even though the range of (3) has been searched, the warning "Cam position calculation cam axis 1 cycle current value calculation disable" (warning code: 0C64H) will occur in reciprocated cam pattern. For the feed cam, calculates "[Cd.618] Cam position calculation: Cam axis feed current value" by the stroke difference and searches again from the 0th point to the whole range. If the corresponding position is not found even though the search process starts again, the warning "Cam position calculation cam axis 1 cycle current value calculation disable" (warning code: 0C64H) will occur.

Ex.

When "[Cd.617] Cam position calculation: Cam axis current value per cycle" is corresponding to the last point of cam data

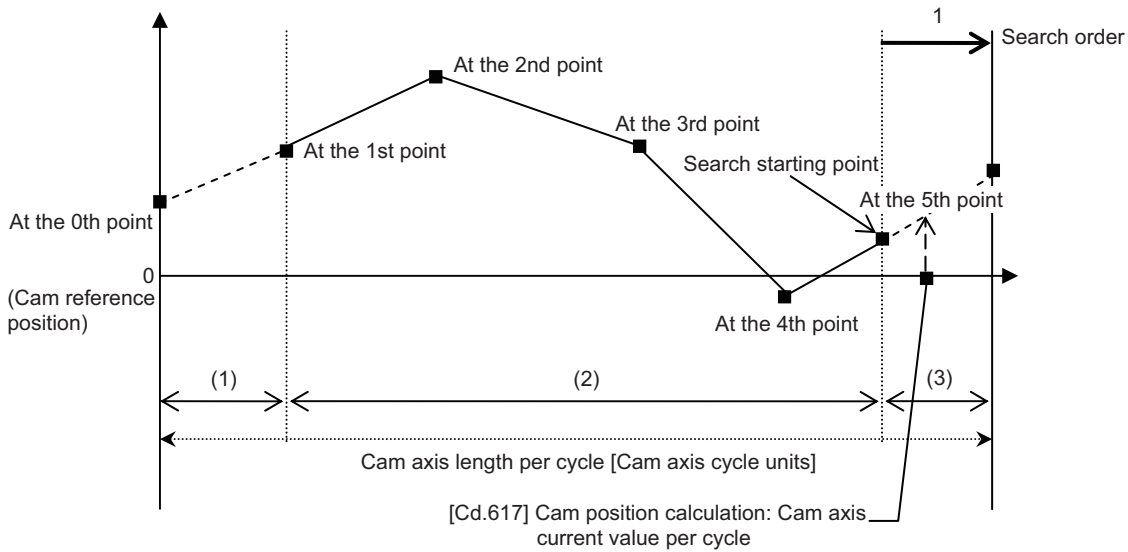

- Searches from the range of (3).

5.6 Method to Restart Synchronous Control

The relationship of the synchronous position for synchronous control is always saved in the Simple Motion module. Synchronous control can be restarted without returning all axes to their starting points by restoring the synchronized relationship through the synchronous control initial position parameters ( Page 147 Synchronous Control Initial Position Parameters).

The reference axis used to restart synchronous control is different for each system. The following procedure shows an example of how to restore synchronized values based on the servo input axis as reference position.

Example

Restoring 2 output axes (axis 2, axis 3) based on the servo input axis (axis 1) as the reference position. (Press conveyance device)

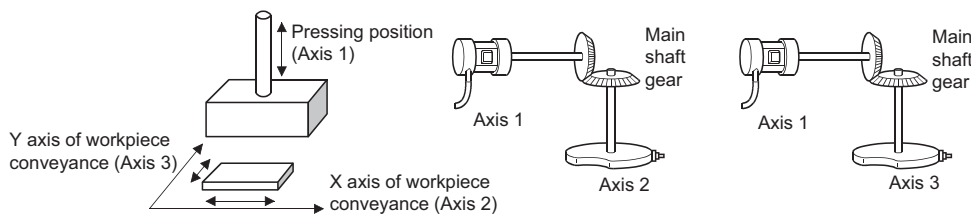

■Procedure for synchronous control (first time)

1. Execute home position return for axis 1, 2 and 3, and position to the synchronization starting point.
2. Set the synchronous control initial position parameters for axis 2 and 3 as follows.

Setting item	Setting value
[Pr.460] Setting method of current value per cycle after main shaft gear	2: Calculate from input axis
[Pr.462] Cam axis position restoration object	0: Cam axis current value per cycle restoration
[Pr.463] Setting method of cam reference position	2: Feed current value
[Pr.468] Cam axis current value per cycle (Initial setting)	0

3. Turn ON the bits for axis 2 and 3 in "[Cd.380] Synchronous control start" to start synchronous control.

■Procedure for restarting synchronous control

1. Set the synchronous control initial position parameters for axis 2 and 3 as follows.

Setting item	Setting value
[Pr.460] Setting method of current value per cycle after main shaft gear	2: Calculate from input axis
[Pr.462] Cam axis position restoration object	2: Cam axis feed current value restoration
[Pr.463] Setting method of cam reference position	0: Previous value
[Pr.464] Setting method of cam axis current value per cycle	2: Current value per cycle after main shaft gear

2. Turn ON the bits for axes 2 and 3 in "[Cd.381] Synchronous control analysis mode", and then turn ON the bits for axes 2 and 3 in "[Cd.380] Synchronous control start" to execute the synchronous control analysis. The analyzed result is updated in [Md.400] to [Md.425].
3. Position axes 2 and 3 to "[Md.409] Cam axis feed current value" which has been updated in 2.
4. Turn OFF the bits for axes 2 and 3 in "[Cd.381] Synchronous control analysis mode", and then turn ON the bits for axes 2 and 3 in "[Cd.380] Synchronous control start" to start synchronous control.

APPENDICES

Appendix 1 List of Buffer Memory Addresses (for Synchronous Control)

The following shows the relation between the buffer memory addresses and the various items.

Refer to the following for the list of general buffer memory addresses.

📖 MELSEC iQ-R Simple Motion Module User's Manual (Application)

Refer to the following for the list of buffer memory addresses for network.

📖 MELSEC iQ-R Simple Motion Module User's Manual (Network)

Parameter

■ Servo input axis parameter

n: Axis No. - 1 (n: Axis No. - 17 for axis 17 to axis 32)

Item		Buffer memory address	
		Axis 1 to axis 16	Axis 17 to axis 32
[Pr.300]	Servo input axis type	32800+10n	1032800+10n
[Pr.301]	Servo input axis smoothing time constant	32801+10n	1032801+10n
[Pr.302]	Servo input axis phase compensation advance time	32802+10n 32803+10n	1032802+10n 1032803+10n
[Pr.303]	Servo input axis phase compensation time constant	32804+10n	1032804+10n
[Pr.304]	Servo input axis rotation direction restriction	32805+10n	1032805+10n

■ Synchronous encoder axis parameter

j: Synchronous encoder axis No. - 1 (j: Axis No. - 17 for axis 17 to axis 32)

Item		Buffer memory address	
		Axis 1 to axis 16	Axis 17 to axis 32
[Pr.320]	Synchronous encoder axis type	34720+20j	1034720+20j
[Pr.321]	Synchronous encoder axis unit setting	34721+20j	1034721+20j
[Pr.322]	Synchronous encoder axis unit conversion: Numerator	34722+20j 34723+20j	1034722+20j 1034723+20j
[Pr.323]	Synchronous encoder axis unit conversion: Denominator	34724+20j 34725+20j	1034724+20j 1034725+20j
[Pr.324]	Synchronous encoder axis length per cycle	34726+20j 34727+20j	1034726+20j 1034727+20j
[Pr.325]	Synchronous encoder axis smoothing time constant	34728+20j	1034728+20j
[Pr.326]	Synchronous encoder axis phase compensation advance time	34730+20j 34731+20j	1034730+20j 1034731+20j
[Pr.327]	Synchronous encoder axis phase compensation time constant	34732+20j	1034732+20j
[Pr.328]	Synchronous encoder axis rotation direction restriction	34733+20j	1034733+20j
[Pr.329]	Resolution of synchronous encoder via CPU	34734+20j 34735+20j	1034734+20j 1034735+20j

■ Synchronous encoder axis parameter via link device [RD77GF]

j: Synchronous encoder axis No. - 1 (j: Axis No. - 17 for axis 17 to axis 32)

Item		Buffer memory address	
		Axis 1 to axis 16	Axis 17 to axis 32
[Pr.710]	Synchronous encoder axis: Link device type	35520+20j	1035520+20j
[Pr.711]	Synchronous encoder axis: Link device start No.	35521+20j	1035521+20j
[Pr.712]	Synchronous encoder axis: Link device count direction setting	35526+20j	1035526+20j
[Pr.713]	Synchronous encoder axis: Ring counter maximum value	35522+20j 35523+20j	1035522+20j 1035523+20j

Item		Buffer memory address	
		Axis 1 to axis 16	Axis 17 to axis 32
[Pr.714]	Synchronous encoder axis: Ring counter minimum value	35524+20j 35525+20j	1035524+20j 1035525+20j
[Pr.1010]	Synchronous encoder axis start request: Link device type	35530+20j	1035530+20j
[Pr.1011]	Synchronous encoder axis start request: Link device start No.	35531+20j	1035531+20j
[Pr.1012]	Synchronous encoder axis start request: Link device bit specification	35532+20j	1035532+20j
[Pr.1013]	Synchronous encoder axis start request: Link device logic setting	35533+20j	1035533+20j

■Synchronous parameter: Main shaft

n: Axis No. - 1 (n: Axis No. - 17 for axis 17 to axis 32)

Item		Buffer memory address	
		Axis 1 to axis 16	Axis 17 to axis 32
[Pr.400]	Main input axis No.	36400+200n	1036400+200n
[Pr.401]	Sub input axis No.	36401+200n	1036401+200n
[Pr.402]	Composite main shaft gear	36402+200n	1036402+200n
[Pr.403]	Main shaft gear: Numerator	36404+200n 36405+200n	1036404+200n 1036405+200n
[Pr.404]	Main shaft gear: Denominator	36406+200n 36407+200n	1036406+200n 1036407+200n
[Pr.405]	Main shaft clutch control setting	36408+200n	1036408+200n
[Pr.406]	Main shaft clutch reference address setting	36409+200n	1036409+200n
[Pr.407]	Main shaft clutch ON address	36410+200n 36411+200n	1036410+200n 1036411+200n
[Pr.408]	Movement amount before main shaft clutch ON	36412+200n 36413+200n	1036412+200n 1036413+200n
[Pr.409]	Main shaft clutch OFF address	36414+200n 36415+200n	1036414+200n 1036415+200n
[Pr.410]	Movement amount before main shaft clutch OFF	36416+200n 36417+200n	1036416+200n 1036417+200n
[Pr.411]	Main shaft clutch smoothing method	36418+200n	1036418+200n
[Pr.412]	Main shaft clutch smoothing time constant	36419+200n	1036419+200n
[Pr.413]	Slippage at main shaft clutch ON	36420+200n 36421+200n	1036420+200n 1036421+200n
[Pr.414]	Slippage at main shaft clutch OFF	36422+200n 36423+200n	1036422+200n 1036423+200n

■Synchronous parameter: Auxiliary shaft

n: Axis No. - 1 (n: Axis No. - 17 for axis 17 to axis 32)

Item		Buffer memory address	
		Axis 1 to axis 16	Axis 17 to axis 32
[Pr.418]	Auxiliary shaft axis No.	36430+200n	1036430+200n
[Pr.419]	Composite auxiliary shaft gear	36431+200n	1036431+200n
[Pr.420]	Auxiliary shaft gear: Numerator	36432+200n 36433+200n	1036432+200n 1036433+200n
[Pr.421]	Auxiliary shaft gear: Denominator	36434+200n 36435+200n	1036434+200n 1036435+200n
[Pr.422]	Auxiliary shaft clutch control setting	36436+200n	1036436+200n
[Pr.423]	Auxiliary shaft clutch reference address setting	36437+200n	1036437+200n
[Pr.424]	Auxiliary shaft clutch ON address	36438+200n 36439+200n	1036438+200n 1036439+200n
[Pr.425]	Movement amount before auxiliary shaft clutch ON	36440+200n 36441+200n	1036440+200n 1036441+200n
[Pr.426]	Auxiliary shaft clutch OFF address	36442+200n 36443+200n	1036442+200n 1036443+200n
[Pr.427]	Movement amount before auxiliary shaft clutch OFF	36444+200n 36445+200n	1036444+200n 1036445+200n
[Pr.428]	Auxiliary shaft clutch smoothing method	36446+200n	1036446+200n

A

Item		Buffer memory address	
		Axis 1 to axis 16	Axis 17 to axis 32
[Pr.429]	Auxiliary shaft clutch smoothing time constant	36447+200n	1036447+200n
[Pr.430]	Slippage at auxiliary shaft clutch ON	36448+200n 36449+200n	1036448+200n 1036449+200n
[Pr.431]	Slippage at auxiliary shaft clutch OFF	36450+200n 36451+200n	1036450+200n 1036451+200n

■Synchronous parameter: Speed change gear

n: Axis No. - 1 (n: Axis No. - 17 for axis 17 to axis 32)

Item		Buffer memory address	
		Axis 1 to axis 16	Axis 17 to axis 32
[Pr.434]	Speed change gear	36460+200n	1036460+200n
[Pr.435]	Speed change gear smoothing time constant	36461+200n	1036461+200n
[Pr.436]	Speed change ratio: Numerator	36462+200n 36463+200n	1036462+200n 1036463+200n
[Pr.437]	Speed change ratio: Denominator	36464+200n 36465+200n	1036464+200n 1036465+200n

■Synchronous parameter: Output axis

n: Axis No. - 1 (n: Axis No. - 17 for axis 17 to axis 32)

Item		Buffer memory address	
		Axis 1 to axis 16	Axis 17 to axis 32
[Pr.438]	Cam axis cycle unit setting	36470+200n	1036470+200n
[Pr.439]	Cam axis length per cycle	36472+200n 36473+200n	1036472+200n 1036473+200n
[Pr.440]	Cam No.	36474+200n	1036474+200n
[Pr.441]	Cam stroke amount	36476+200n 36477+200n	1036476+200n 1036477+200n
[Pr.442]	Cam axis length per cycle change setting	36471+200n	1036471+200n
[Pr.444]	Cam axis phase compensation advance time	36482+200n 36483+200n	1036482+200n 1036483+200n
[Pr.445]	Cam axis phase compensation time constant	36484+200n	1036484+200n
[Pr.446]	Synchronous control deceleration time	36485+200n	1036485+200n
[Pr.447]	Output axis smoothing time constant	36486+200n	1036486+200n

■Synchronous parameter: Synchronous control initial position

n: Axis No. - 1 (n: Axis No. - 17 for axis 17 to axis 32)

Item		Buffer memory address	
		Axis 1 to axis 16	Axis 17 to axis 32
[Pr.460]	Setting method of current value per cycle after main shaft gear	36500+200n	1036500+200n
[Pr.461]	Setting method of current value per cycle after auxiliary shaft gear	36501+200n	1036501+200n
[Pr.462]	Cam axis position restoration object	36502+200n	1036502+200n
[Pr.463]	Setting method of cam reference position	36503+200n	1036503+200n
[Pr.464]	Setting method of cam axis current value per cycle	36504+200n	1036504+200n
[Pr.465]	Current value per cycle after main shaft gear (Initial setting)	36506+200n 36507+200n	1036506+200n 1036507+200n
[Pr.466]	Current value per cycle after auxiliary shaft gear (Initial setting)	36508+200n 36509+200n	1036508+200n 1036509+200n
[Pr.467]	Cam reference position (Initial setting)	36510+200n 36511+200n	1036510+200n 1036511+200n
[Pr.468]	Cam axis current value per cycle (Initial setting)	36512+200n 36513+200n	1036512+200n 1036513+200n

Monitor data

■ Servo input axis monitor data

n: Axis No. - 1 (n: Axis No. - 17 for axis 17 to axis 32)

Item		Buffer memory address	
		Axis 1 to axis 16	Axis 17 to axis 32
[Md.300]	Servo input axis current value	33120+10n 33121+10n	1033120+10n 1033121+10n
[Md.301]	Servo input axis speed	33122+10n 33123+10n	1033122+10n 1033123+10n
[Md.302]	Servo input axis phase compensation amount	33124+10n 33125+10n	1033124+10n 1033125+10n
[Md.303]	Servo input axis rotation direction restriction amount	33126+10n 33127+10n	1033126+10n 1033127+10n

■ Synchronous encoder axis monitor data

j: Synchronous encoder axis No. - 1 (j: Axis No. - 17 for axis 17 to axis 32)

Item		Buffer memory address	
		Axis 1 to axis 16	Axis 17 to axis 32
[Md.320]	Synchronous encoder axis current value	35200+20j 35201+20j	1035200+20j 1035201+20j
[Md.321]	Synchronous encoder axis current value per cycle	35202+20j 35203+20j	1035202+20j 1035203+20j
[Md.322]	Synchronous encoder axis speed	35204+20j 35205+20j	1035204+20j 1035205+20j
[Md.323]	Synchronous encoder axis phase compensation amount	35206+20j 35207+20j	1035206+20j 1035207+20j
[Md.324]	Synchronous encoder axis rotation direction restriction amount	35208+20j 35209+20j	1035208+20j 1035209+20j
[Md.325]	Synchronous encoder axis status	35210+20j	1035210+20j
[Md.326]	Synchronous encoder axis error No.	35211+20j	1035211+20j
[Md.327]	Synchronous encoder axis warning No.	35212+20j	1035212+20j

■ Synchronous control monitor data

n: Axis No. - 1 (n: Axis No. - 17 for axis 17 to axis 32)

Item		Buffer memory address	
		Axis 1 to axis 16	Axis 17 to axis 32
[Md.400]	Current value after composite main shaft gear	42800+40n 42801+40n	1042800+40n 1042801+40n
[Md.401]	Current value per cycle after main shaft gear	42802+40n 42803+40n	1042802+40n 1042803+40n
[Md.402]	Current value per cycle after auxiliary shaft gear	42804+40n 42805+40n	1042804+40n 1042805+40n
[Md.406]	Cam axis phase compensation amount	42810+40n 42811+40n	1042810+40n 1042811+40n
[Md.407]	Cam axis current value per cycle	42812+40n 42813+40n	1042812+40n 1042813+40n
[Md.408]	Cam reference position	42814+40n 42815+40n	1042814+40n 1042815+40n
[Md.409]	Cam axis feed current value	42816+40n 42817+40n	1042816+40n 1042817+40n
[Md.410]	Execute cam No.	42818+40n	1042818+40n
[Md.411]	Execute cam stroke amount	42820+40n 42821+40n	1042820+40n 1042821+40n
[Md.412]	Execute cam axis length per cycle	42822+40n 42823+40n	1042822+40n 1042823+40n
[Md.420]	Main shaft clutch ON/OFF status	42828+40n	1042828+40n
[Md.421]	Main shaft clutch smoothing status	42829+40n	1042829+40n

A

Item		Buffer memory address	
		Axis 1 to axis 16	Axis 17 to axis 32
[Md.422]	Main shaft clutch slippage (accumulative)	42830+40n 42831+40n	1042830+40n 1042831+40n
[Md.423]	Auxiliary shaft clutch ON/OFF status	42832+40n	1042832+40n
[Md.424]	Auxiliary shaft clutch smoothing status	42833+40n	1042833+40n
[Md.425]	Auxiliary shaft clutch slippage (accumulative)	42834+40n 42835+40n	1042834+40n 1042835+40n

■Synchronous control monitor data: Cam position calculation

Item		Buffer memory address
[Md.600]	Cam position calculation result	53800 53801

Control data

■Synchronous control system control data

Item		Buffer memory address	
		Axis 1 to axis 16	Axis 17 to axis 32
[Cd.380]	Synchronous control start	36320	1036320
[Cd.381]	Synchronous control analysis mode	36322	1036322

■Synchronous encoder axis control data

j: Synchronous encoder axis No. - 1 (j: Axis No. - 17 for axis 17 to axis 32)

Item		Buffer memory address	
		Axis 1 to axis 16	Axis 17 to axis 32
[Cd.320]	Synchronous encoder axis control start	35040+10j	1035040+10j
[Cd.321]	Synchronous encoder axis control method	35041+10j	1035041+10j
[Cd.322]	Synchronous encoder axis current value setting address	35042+10j 35043+10j	1035042+10j 1035043+10j
[Cd.323]	Synchronous encoder axis error reset	35044+10j	1035044+10j
[Cd.324]	Connection command of synchronous encoder via CPU	35045+10j	1035045+10j
[Cd.325]	Input value for synchronous encoder via CPU	35046+10j 35047+10j	1035046+10j 1035047+10j

■Control data for synchronous control

n: Axis No. - 1 (n: Axis No. - 17 for axis 17 to axis 32)

Item		Buffer memory address	
		Axis 1 to axis 16	Axis 17 to axis 32
[Cd.400]	Main shaft clutch command	44080+20n	1044080+20n
[Cd.401]	Main shaft clutch control invalid command	44081+20n	1044081+20n
[Cd.402]	Main shaft clutch forced OFF command	44082+20n	1044082+20n
[Cd.403]	Auxiliary shaft clutch command	44083+20n	1044083+20n
[Cd.404]	Auxiliary shaft clutch control invalid command	44084+20n	1044084+20n
[Cd.405]	Auxiliary shaft clutch forced OFF command	44085+20n	1044085+20n
[Cd.406]	Synchronous control change request	44086+20n	1044086+20n
[Cd.407]	Synchronous control change command	44087+20n	1044087+20n
[Cd.408]	Synchronous control change value	44088+20n 44089+20n	1044088+20n 1044089+20n
[Cd.409]	Synchronous control reflection time	44090+20n	1044090+20n

■Cam operation control data: Cam data operation

Item		Buffer memory address
[Cd.600]	Cam data operation request	45000 [RD77MS] 600000 [RD77GF]
[Cd.601]	Operation cam No.	45001 [RD77MS] 600001 [RD77GF]
[Cd.602]	Cam data first position	45002 [RD77MS] 600002 [RD77GF]
[Cd.603]	Number of cam data operation points	45003 [RD77MS] 600003 [RD77GF]
[Cd.604]	Cam data format	45004 [RD77MS] 600004 [RD77GF]
[Cd.605]	Cam resolution/coordinate number	45005 [RD77MS] 600005 [RD77GF]
[Cd.606]	Cam data starting point	45006 [RD77MS] 600006 [RD77GF]
[Cd.607]	Cam data value *1	45008 to 53199 [RD77MS] 600008 to 862147 [RD77GF]

A

*1 The item details on the cam data are shown below.

• Data for rotary cutter (central reference) [RD77GF]

Details	Buffer memory address
Resolution	600008 600009
Auto-generation option	600010
Synchronous section acceleration ratio	600011
Sheet length	600012 600013
Sheet synchronous width	600014 600015
Synchronous axis length	600016 600017
Synchronous position adjustment	600018 600019
Acceleration/deceleration width	600020 600021
Number of cutter	600022
Asynchronous speed result	600023

• Easy stroke ratio cam data [RD77GF]

Details	Buffer memory address
Resolution	600008 600009
Cam axis length per cycle	600010 600011
Cam data starting point	600012 600013
Number of sections	600014
Section 1	Cam curve type
	End point
	Stroke
⋮	⋮
Section 32	Cam curve type
	End point
	Stroke

• Advanced stroke ratio cam data for auto-generation [RD77GF]

Details		Buffer memory address
Resolution		600008 600009
Cam axis length per cycle		600010 600011
Cam stroke amount		600012 600013
Unit setting		600014
Cam data starting point		600016 600017
Number of sections		600018
Section 1	Cam curve type	600020
	End point	600022 600023
	Stroke	600024 600025
	Curve applicable range (P1)	600026
	Curve applicable range (P2)	600027
	Acceleration/deceleration range compensation (Range L1)	600028
	Acceleration/deceleration range compensation (Range L2)	600029
	⋮	⋮
Section 360	Cam curve type	603610
	End point	603612 603613
	Stroke	603614 603615
	Curve applicable range (P1)	603616
	Curve applicable range (P2)	603617
	Acceleration/deceleration range compensation (Range L1)	603618
	Acceleration/deceleration range compensation (Range L2)	603619



■Cam operation control data: Cam auto-generation

Item		Buffer memory address
[Cd.608]	Cam auto-generation request	53200 [RD77MS] 862200 [RD77GF]
[Cd.609]	Cam auto-generation cam No.	53201 [RD77MS] 862201 [RD77GF]
[Cd.610]	Cam auto-generation type	53202 [RD77MS] 862202 [RD77GF]
[Cd.611]	Cam auto-generation data ^{*1}	53204 to 53779 [RD77MS] 862204 to 866295 [RD77GF]

*1 The item details on the auto-generation parameter are shown below.

- Cam auto-generation data for rotary cutter [RD77MS]

Details	Buffer memory address
Resolution	53204
Sheet length	53206 53207
Sheet synchronous width	53208 53209
Synchronous axis length	53210 53211
Synchronization starting point	53212 53213
Synchronous section acceleration ratio	53214

- Cam auto-generation data for rotary cutter (central reference) [RD77GF]

Details	Buffer memory address
Resolution	862204 862205
Auto-generation option	862206
Synchronous section acceleration ratio	862207
Sheet length	862208 862209
Sheet synchronous width	862210 862211
Synchronous axis length	862212 862213
Synchronous position adjustment	862214 862215
Acceleration/deceleration width	862216 862217
Number of cutter	862218
Asynchronous speed result	862219

• Easy stroke ratio cam data for auto-generation [RD77GF]

Details		Buffer memory address
Resolution		862204 862205
Cam axis length per cycle		862206 862207
Cam data starting point		862208 862209
Number of sections		862210
Section 1	Cam curve type	862212
	End point	862214 862215
	Stroke	862216 862217
⋮	⋮	⋮
Section 32	Cam curve type	862398
	End point	862400 862401
	Stroke	862402 862403

• Advanced stroke ratio cam data for auto-generation [RD77GF]

Details		Buffer memory address
Resolution		862204 862205
Cam axis length per cycle		862206 862207
Cam stroke amount		862208 862209
Unit setting		862210
Cam data starting point		862212 862213
Number of sections		862214
Section 1	Cam curve type	862216
	End point	862218 862219
	Stroke	862220 862221
	Curve applicable range (P1)	862222
	Curve applicable range (P2)	862223
	Acceleration/deceleration range compensation (Range L1)	862224
	Acceleration/deceleration range compensation (Range L2)	862225
	⋮	⋮
Section 360	Cam curve type	865806
	End point	865808 865809
	Stroke	865810 865811
	Curve applicable range (P1)	865812
	Curve applicable range (P2)	865813
	Acceleration/deceleration range compensation (Range L1)	865814
	Acceleration/deceleration range compensation (Range L2)	865815



■Cam operation control data: Cam position calculation

Item		Buffer memory address
[Cd.612]	Cam position calculation request	53780
[Cd.613]	Cam position calculation: Cam No.	53781
[Cd.614]	Cam position calculation: Stroke amount	53782 53783
[Cd.615]	Cam position calculation: Cam axis length per cycle	53784 53785
[Cd.616]	Cam position calculation: Cam reference position	53786 53787
[Cd.617]	Cam position calculation: Cam axis current value per cycle	53788 53789
[Cd.618]	Cam position calculation: Cam axis feed current value	53790 53791

Appendix 2 Sample Program of Synchronous Control of the RD77MS

The following shows a sample program of executing synchronous control on the axis 1 with the axis 4 as an input axis using 4-axis modules. (The axis 4 is configured as the virtual servo amplifier.)

1. Set MR-J4(W)-B(-RJ) on the axis 1 and the virtual servo amplifier on the axis 4 in the "System Configuration" window.

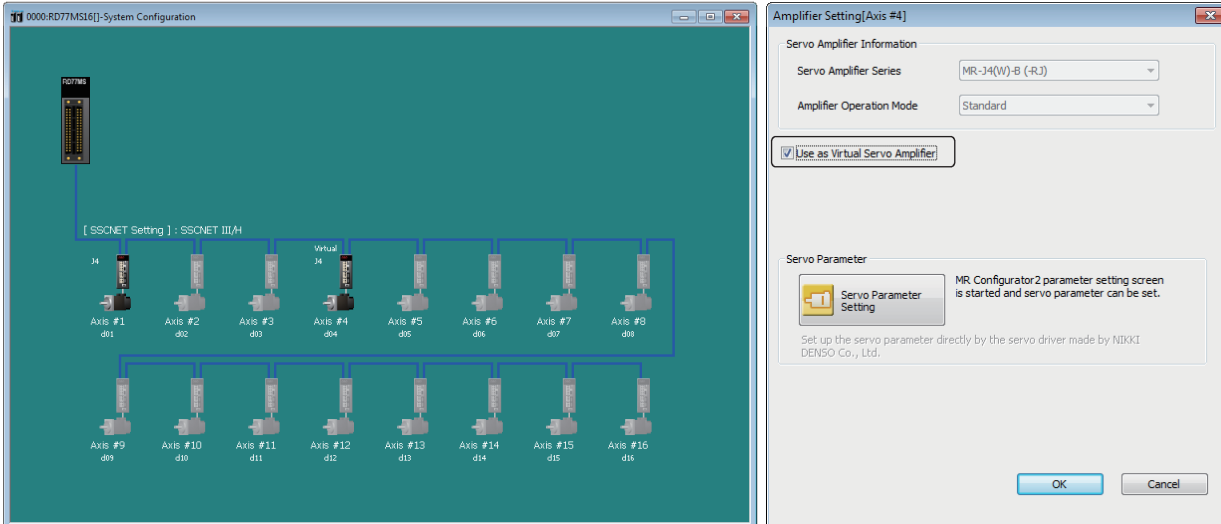

2. Set the axis 4 as the servo input axis in the "Input Axis Parameter" window.

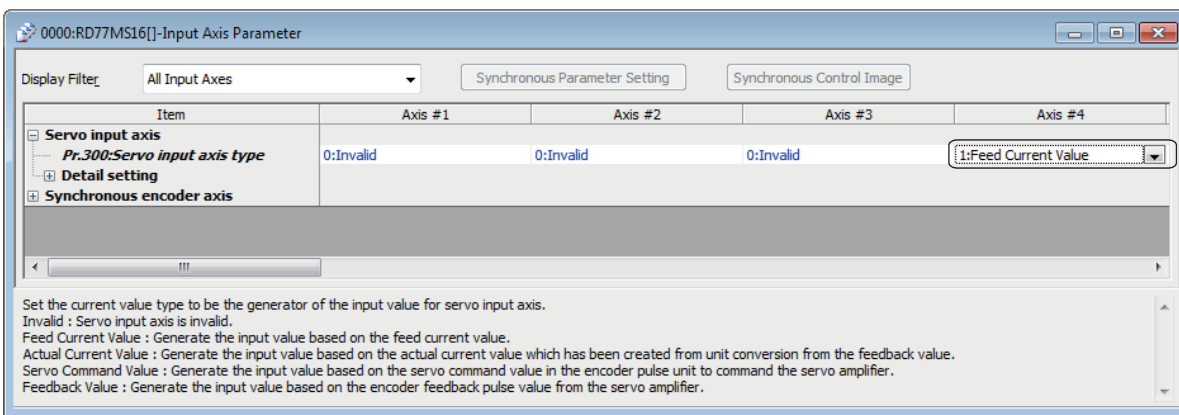

3. Create the cam data (cam No.1).

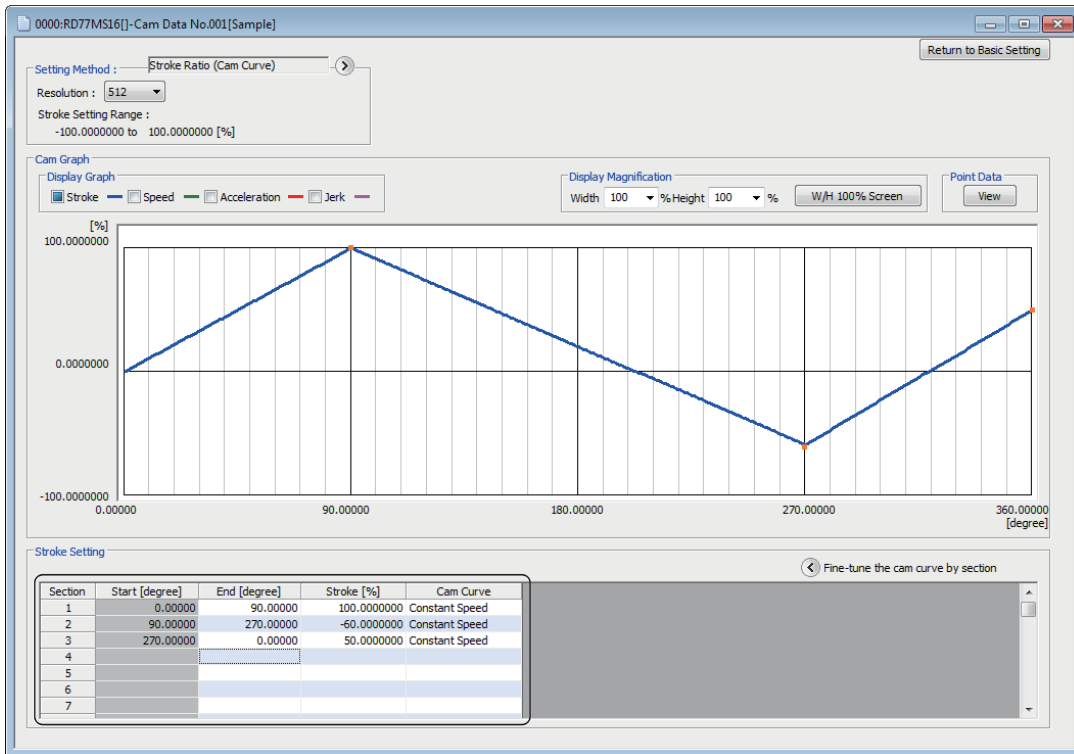

4. Set the synchronous parameter of the axis 1.

Item	Axis #1
Synchronous control module setting	
Set each module parameter.	
Main shaft	
Main input axis	1:Servo Input Axis
Pr. 400:Type	4
Pr. 400:Axis No.	
Sub input axis	0:Invalid
Pr. 401:Type	0
Pr. 401:Axis No.	
1:Input+	
0:No Input	
Main shaft composite gear	
Pr. 402:Main	
Pr. 402:Sub	
Main shaft gear	
Pr. 403:Numerator	1
Pr. 404:Denominator	1
Main shaft clutch	
Auxiliary shaft	0:Invalid
Pr. 418:Type	0
Pr. 418:Axis No.	
Auxiliary shaft composite gear	
Auxiliary shaft gear	
Auxiliary shaft clutch	
Speed change gear	
Output axis	
Cam axis cycle unit	1:Use Unit in This Setting
Pr. 438:Unit setting selection	2:degree
Pr. 438:Unit	3
Pr. 438:Number of decimal places	
Pr. 442:Cam axis length per cycle change setting	1:Valid
Pr. 439:Cam axis length per cycle	360.000 degree
Pr. 441:Cam stroke amount	100000 pulse
Pr. 440:Cam No.	1
Pr. 444:Cam axis phase compensation advance time	0 μs
Pr. 445:Cam axis phase compensation time constant	10 ms
Pr. 446:Synchronous control deceleration time	0 ms
Pr. 447:Output axis smoothing time constant	0 ms
Synchronous control initial position parameter	Set the parameter for the initial alignment when starting the synchronous control.

5. Create the program to start synchronous control.

The sample program when head I/O No. of the Simple Motion module is set to 00H is shown below.

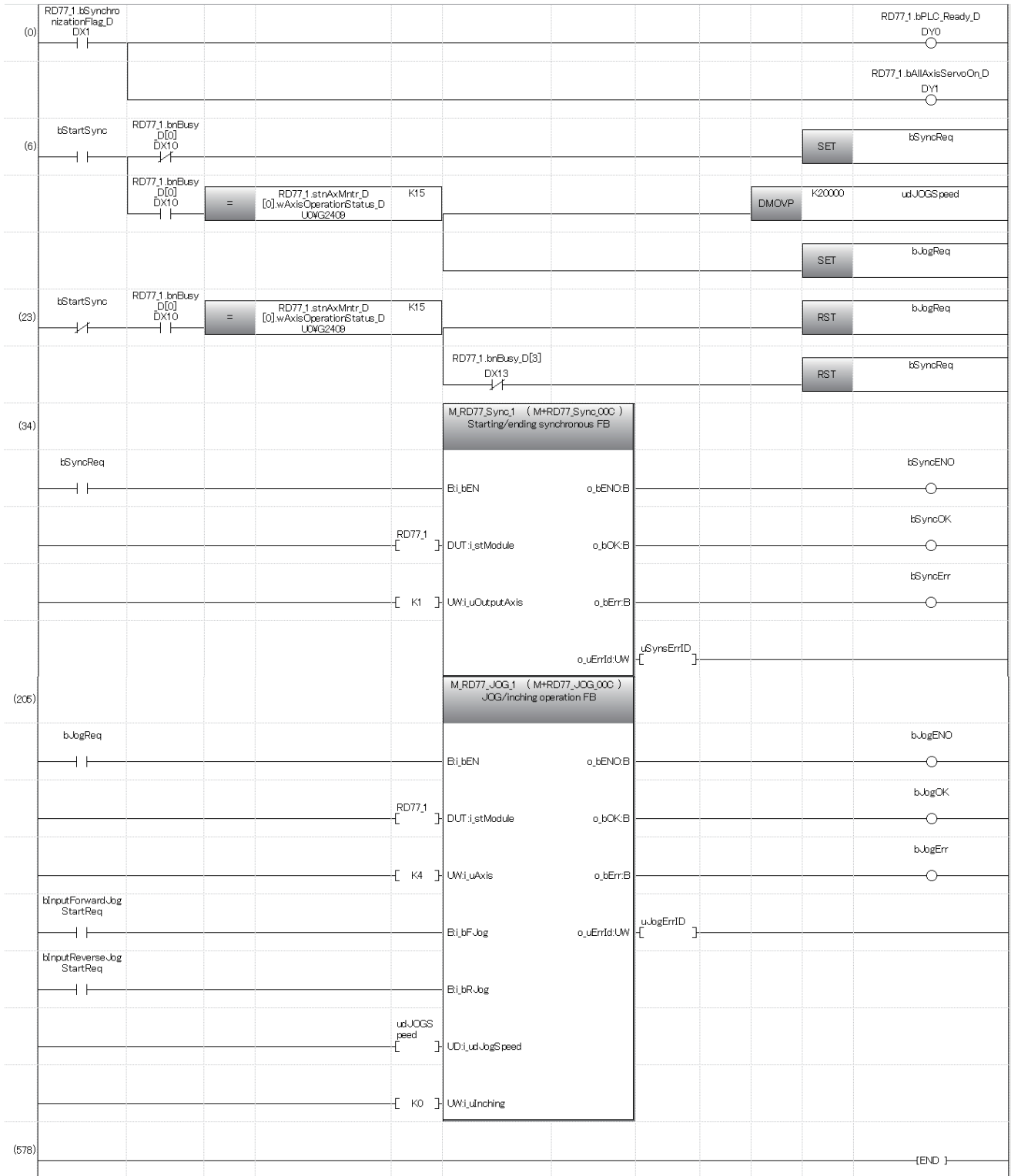

Classification	Label name	Description																																																																
Module label	RD77_1.bSynchronizationFlag_D	Synchronization flag																																																																
	RD77_1.bPLC_Ready_D	PLC READY																																																																
	RD77_1.bAllAxisServoOn_D	All axis servo ON																																																																
	RD77_1.bnBusy_D[0]	Axis 1 BUSY																																																																
	RD77_1.stnAxMntr_D[0].wAxisOperationStatus_D	Axis 1 Axis operation status																																																																
	RD77_1.bnBusy_D[3]	Axis 4 BUSY																																																																
Global label, Local label	<p>Defines the global label or the local label as follows. The settings of Assign (Device/Label) are not required for the label that the assignment device is not set because the unused internal relay and data device are automatically assigned. The following table shows an example for the global label.</p> <table border="1"> <thead> <tr> <th></th> <th>Label Name</th> <th>Data Type</th> <th>Class</th> </tr> </thead> <tbody> <tr><td>1</td><td>bStartSync</td><td>Bit</td><td>VAR_GLOBAL</td></tr> <tr><td>2</td><td>bSyncReq</td><td>Bit</td><td>VAR_GLOBAL</td></tr> <tr><td>3</td><td>uDJGSpeed</td><td>Double Word [Unsigned]/Bit String [32-bit]</td><td>VAR_GLOBAL</td></tr> <tr><td>4</td><td>bJogReq</td><td>Bit</td><td>VAR_GLOBAL</td></tr> <tr><td>5</td><td>bSyncEND</td><td>Bit</td><td>VAR_GLOBAL</td></tr> <tr><td>6</td><td>bSyncOK</td><td>Bit</td><td>VAR_GLOBAL</td></tr> <tr><td>7</td><td>bSyncErr</td><td>Bit</td><td>VAR_GLOBAL</td></tr> <tr><td>8</td><td>uSyncErrID</td><td>Word [Unsigned]/Bit String [16-bit]</td><td>VAR_GLOBAL</td></tr> <tr><td>9</td><td>bJogEND</td><td>Bit</td><td>VAR_GLOBAL</td></tr> <tr><td>10</td><td>bJogOK</td><td>Bit</td><td>VAR_GLOBAL</td></tr> <tr><td>11</td><td>bInputForwardJogStartReq</td><td>Bit</td><td>VAR_GLOBAL</td></tr> <tr><td>12</td><td>bInputReverseJogStartReq</td><td>Bit</td><td>VAR_GLOBAL</td></tr> <tr><td>13</td><td>bJogErr</td><td>Bit</td><td>VAR_GLOBAL</td></tr> <tr><td>14</td><td>uJogErrID</td><td>Word [Unsigned]/Bit String [16-bit]</td><td>VAR_GLOBAL</td></tr> <tr><td>15</td><td></td><td></td><td>...</td></tr> </tbody> </table>			Label Name	Data Type	Class	1	bStartSync	Bit	VAR_GLOBAL	2	bSyncReq	Bit	VAR_GLOBAL	3	uDJGSpeed	Double Word [Unsigned]/Bit String [32-bit]	VAR_GLOBAL	4	bJogReq	Bit	VAR_GLOBAL	5	bSyncEND	Bit	VAR_GLOBAL	6	bSyncOK	Bit	VAR_GLOBAL	7	bSyncErr	Bit	VAR_GLOBAL	8	uSyncErrID	Word [Unsigned]/Bit String [16-bit]	VAR_GLOBAL	9	bJogEND	Bit	VAR_GLOBAL	10	bJogOK	Bit	VAR_GLOBAL	11	bInputForwardJogStartReq	Bit	VAR_GLOBAL	12	bInputReverseJogStartReq	Bit	VAR_GLOBAL	13	bJogErr	Bit	VAR_GLOBAL	14	uJogErrID	Word [Unsigned]/Bit String [16-bit]	VAR_GLOBAL	15			...
	Label Name	Data Type	Class																																																															
1	bStartSync	Bit	VAR_GLOBAL																																																															
2	bSyncReq	Bit	VAR_GLOBAL																																																															
3	uDJGSpeed	Double Word [Unsigned]/Bit String [32-bit]	VAR_GLOBAL																																																															
4	bJogReq	Bit	VAR_GLOBAL																																																															
5	bSyncEND	Bit	VAR_GLOBAL																																																															
6	bSyncOK	Bit	VAR_GLOBAL																																																															
7	bSyncErr	Bit	VAR_GLOBAL																																																															
8	uSyncErrID	Word [Unsigned]/Bit String [16-bit]	VAR_GLOBAL																																																															
9	bJogEND	Bit	VAR_GLOBAL																																																															
10	bJogOK	Bit	VAR_GLOBAL																																																															
11	bInputForwardJogStartReq	Bit	VAR_GLOBAL																																																															
12	bInputReverseJogStartReq	Bit	VAR_GLOBAL																																																															
13	bJogErr	Bit	VAR_GLOBAL																																																															
14	uJogErrID	Word [Unsigned]/Bit String [16-bit]	VAR_GLOBAL																																																															
15			...																																																															

MEMO

A

INDEX

A

Auxiliary shaft axis No.	101,102
Auxiliary shaft clutch command	109
Auxiliary shaft clutch control invalid command	109
Auxiliary shaft clutch control setting	103,104
Auxiliary shaft clutch forced OFF command	109
Auxiliary shaft clutch OFF address	104,107
Auxiliary shaft clutch ON address	103,107
Auxiliary shaft clutch ON/OFF status	136,139
Auxiliary shaft clutch reference address setting	103,106
Auxiliary shaft clutch slippage (accumulative)	136,139
Auxiliary shaft clutch smoothing method	104,108
Auxiliary shaft clutch smoothing status	136,139
Auxiliary shaft clutch smoothing time constant	104,108
Auxiliary shaft gear	
Denominator	101,102
Numerator	101,102

C

Cam auto-generation cam No.	79,80
Cam auto-generation data	79,81
Cam auto-generation request	79,80
Cam auto-generation type	79,80
Cam axis current value per cycle	135,138
Cam axis current value per cycle (Initial setting)	147,149
Cam axis cycle unit setting	127,128
Cam axis feed current value	135,138
Cam axis length per cycle	127,128
Cam axis length per cycle change setting	127,129
Cam axis phase compensation advance time	127,129
Cam axis phase compensation amount	135,138
Cam axis phase compensation time constant	127,130
Cam axis position restoration object	147,148
Cam data first position	74,75
Cam data format	74,76
Cam data operation request	74,75
Cam data starting point	74,76
Cam data value	75,77
Cam No.	127,129
Cam position calculation	
Cam axis current value per cycle	162,163
Cam axis feed current value	162,163
Cam axis length per cycle	162,163
Cam No.	162,163
Cam reference position	162,163
Stroke amount	162,163
Cam position calculation request	162,163
Cam position calculation result	164
Cam reference position	135,138
Cam reference position (Initial setting)	147,149
Cam resolution/coordinate number	74,76
Cam stroke amount	127,129
Composite auxiliary shaft gear	101,102
Composite main shaft gear	92,93

Connection command of synchronous encoder via CPU	55,58
Current value after composite main shaft gear	135,137
Current value per cycle after auxiliary shaft gear	135,138
Current value per cycle after auxiliary shaft gear (Initial setting)	147,149
Current value per cycle after main shaft gear	135,138
Current value per cycle after main shaft gear (Initial setting)	147,149

E

Execute cam axis length per cycle	136,138
Execute cam No.	136,138
Execute cam stroke amount	136,138

I

Input value for synchronous encoder via CPU	55,58
---	-------

M

Main input axis No.	92
Main shaft clutch command	100
Main shaft clutch control invalid command	100
Main shaft clutch control setting	94,96
Main shaft clutch forced OFF command	100
Main shaft clutch OFF address	95,98
Main shaft clutch ON address	94,98
Main shaft clutch ON/OFF status	136,138
Main shaft clutch reference address setting	94,97
Main shaft clutch slippage (accumulative)	136,139
Main shaft clutch smoothing method	95,99
Main shaft clutch smoothing status	136,139
Main shaft clutch smoothing time constant	95,99
Main shaft gear	
Denominator	93
Numerator	93
Movement amount before auxiliary shaft clutch OFF	104,108
Movement amount before auxiliary shaft clutch ON	103,107
Movement amount before main shaft clutch OFF	95,99
Movement amount before main shaft clutch ON	94,98

N

Number of cam data operation points	74,76
---	-------

O

Operation cam No.	74,75
Output axis smoothing time constant	127,130

R

Resolution of synchronous encoder via CPU . . . 47,51

S

Servo input axis current value 33
Servo input axis phase compensation advance time
. 30,31
Servo input axis phase compensation amount . . . 34
Servo input axis phase compensation time constant
. 30,31
Servo input axis rotation direction restriction . . 30,32
Servo input axis rotation direction restriction amount
. 34
Servo input axis smoothing time constant 30,31
Servo input axis speed 34
Servo input axis type 30
Setting method of cam axis current value per cycle
. 147,148
Setting method of cam reference position . . 147,148
Setting method of current value per cycle after auxiliary
shaft gear. 147,148
Setting method of current value per cycle after main shaft
gear. 147,148
Slippage amount at auxiliary shaft clutch OFF
. 104,108
Slippage amount at auxiliary shaft clutch ON
. 104,108
Slippage amount at main shaft clutch OFF. . . . 95,99
Slippage amount at main shaft clutch ON 95,99
Speed change gear. 124
Speed change gear smoothing time constant. . . 124
Speed change ratio
 Denominator 124
 Numerator. 124
Sub input axis No. 92
Synchronous control change command 131,132
Synchronous control change request 131
Synchronous control change value 131,133
Synchronous control deceleration time 127,130
Synchronous control reflection time. 131,134
Synchronous encoder axis
 Link device count direction setting 52,53
 Link device start number. 52,53
 Link device type. 52,53
 Ring counter maximum value 52,53
 Ring counter minimum value 52,53
Synchronous encoder axis control method. . . . 55,57
Synchronous encoder axis control start 55,56
Synchronous encoder axis current value 59
Synchronous encoder axis current value per cycle
. 59
Synchronous encoder axis current value setting address
. 55,57
Synchronous encoder axis error No 59,61
Synchronous encoder axis error reset 55,57
Synchronous encoder axis length per cycle . . . 46,49
Synchronous encoder axis phase compensation
advance time 46,50
Synchronous encoder axis phase compensation amount
. 59,60
Synchronous encoder axis phase compensation time
constant. 46,50
Synchronous encoder axis rotation direction restriction
. 46,51

Synchronous encoder axis rotation direction restriction
amount 59,60
Synchronous encoder axis smoothing time constant
. 46,50
Synchronous encoder axis speed 59,60
Synchronous encoder axis start request
 Link device bit specification 52,54
 Link device logic setting 52,54
 Link device start number 52,54
 Link device type 52,54
Synchronous encoder axis status 59,60
Synchronous encoder axis type 46,47
Synchronous encoder axis unit conversion
 Denominator 46,48
 Numerator 46,47
Synchronous encoder axis unit setting 46,47
Synchronous encoder axis warning No. 59,61

REVISIONS

*The manual number is given on the bottom left of the back cover.

Revision date	*Manual number	Description
June 2014	IB(NA)-0300249ENG-A	First edition
February 2015	IB(NA)-0300249ENG-B	<ul style="list-style-type: none"> ■Added functions MR-JE-B ■Added or modified parts RELEVANT MANUALS, TERMS, Section 1.1, 2.2, 3.1, 4.1, 4.2, 4.3, 4.5, 4.7, 4.8, 5.1, 5.5, Appendix 1
May 2015	IB(NA)-0300249ENG-C	<ul style="list-style-type: none"> ■Added or modified parts Section 1.1, 2.1
March 2016	IB(NA)-0300249ENG-D	<ul style="list-style-type: none"> ■Added models RD77GF4, RD77GF8, RD77GF16 ■Added functions Synchronous encoder via link device ■Added or modified parts SAFETY PRECAUTIONS, INTRODUCTION, RELEVANT MANUALS, TERMS, Chapter 1, Section 1.1, 1.2, 1.3, Chapter 2, Section 2.1, 2.2, 3.1, 3.2, Chapter 4, Section 4.1, 4.2, 4.3, 4.5, 4.7, 4.8, 4.9, Chapter 5, Section 5.3, 5.4, 5.5, Appendix 1, Appendix 2, WARRANTY
December 2016	IB(NA)-0300249ENG-E	<ul style="list-style-type: none"> ■Added models RD77GF32 ■Added or modified parts SAFETY PRECAUTIONS, RELEVANT MANUALS, TERMS, Chapter 1, Section 1.1, 1.2, 1.3, Chapter 2, Section 2.1, 2.2, 3.1, 3.2, Chapter 4, Section 4.1, 4.2, 4.3, 4.5, 4.6, 4.7, 4.8, Chapter 5, Section 5.2, 5.3, 5.4, Appendix 1, Appendix 2
June 2018	IB(NA)-0300249ENG-F	<ul style="list-style-type: none"> ■Added functions MR-JE-BF ■Added or modified parts SAFETY PRECAUTIONS, RELEVANT MANUALS, TERMS, Section 2.1, 2.2, 3.1, 4.8, 4.9

Japanese manual number: IB-0300248-G

This manual confers no industrial property rights of any other kind, nor does it confer any patent licenses. Mitsubishi Electric Corporation cannot be held responsible for any problems involving industrial property rights which may occur as a result of using the contents noted in this manual.

©2014 MITSUBISHI ELECTRIC CORPORATION

WARRANTY

Please confirm the following product warranty details before using this product.

1. Gratis Warranty Term and Gratis Warranty Range

If any faults or defects (hereinafter "Failure") found to be the responsibility of Mitsubishi occurs during use of the product within the gratis warranty term, the product shall be repaired at no cost via the sales representative or Mitsubishi Service Company.

However, if repairs are required onsite at domestic or overseas location, expenses to send an engineer will be solely at the customer's discretion. Mitsubishi shall not be held responsible for any re-commissioning, maintenance, or testing on-site that involves replacement of the failed module.

[Gratis Warranty Term]

The gratis warranty term of the product shall be for one year after the date of purchase or delivery to a designated place. Note that after manufacture and shipment from Mitsubishi, the maximum distribution period shall be six (6) months, and the longest gratis warranty term after manufacturing shall be eighteen (18) months. The gratis warranty term of repair parts shall not exceed the gratis warranty term before repairs.

[Gratis Warranty Range]

- (1) The range shall be limited to normal use within the usage state, usage methods and usage environment, etc., which follow the conditions and precautions, etc., given in the instruction manual, user's manual and caution labels on the product.
- (2) Even within the gratis warranty term, repairs shall be charged for in the following cases.
 1. Failure occurring from inappropriate storage or handling, carelessness or negligence by the user. Failure caused by the user's hardware or software design.
 2. Failure caused by unapproved modifications, etc., to the product by the user.
 3. When the Mitsubishi product is assembled into a user's device, Failure that could have been avoided if functions or structures, judged as necessary in the legal safety measures the user's device is subject to or as necessary by industry standards, had been provided.
 4. Failure that could have been avoided if consumable parts (battery, backlight, fuse, etc.) designated in the instruction manual had been correctly serviced or replaced.
 5. Failure caused by external irresistible forces such as fires or abnormal voltages, and Failure caused by force majeure such as earthquakes, lightning, wind and water damage.
 6. Failure caused by reasons unpredictable by scientific technology standards at time of shipment from Mitsubishi.
 7. Any other failure found not to be the responsibility of Mitsubishi or that admitted not to be so by the user.

2. Onerous repair term after discontinuation of production

- (1) Mitsubishi shall accept onerous product repairs for seven (7) years after production of the product is discontinued. Discontinuation of production shall be notified with Mitsubishi Technical Bulletins, etc.
- (2) Product supply (including repair parts) is not available after production is discontinued.

3. Overseas service

Overseas, repairs shall be accepted by Mitsubishi's local overseas FA Center. Note that the repair conditions at each FA Center may differ.

4. Exclusion of loss in opportunity and secondary loss from warranty liability

Regardless of the gratis warranty term, Mitsubishi shall not be liable for compensation to:

- (1) Damages caused by any cause found not to be the responsibility of Mitsubishi.
- (2) Loss in opportunity, lost profits incurred to the user by Failures of Mitsubishi products.
- (3) Special damages and secondary damages whether foreseeable or not, compensation for accidents, and compensation for damages to products other than Mitsubishi products.
- (4) Replacement by the user, maintenance of on-site equipment, start-up test run and other tasks.

5. Changes in product specifications

The specifications given in the catalogs, manuals or technical documents are subject to change without prior notice.

TRADEMARKS

Ethernet is a registered trademark of Fuji Xerox Co., Ltd. in Japan.

Microsoft and Windows are either registered trademarks or trademarks of Microsoft Corporation in the United States and/or other countries.

The company names, system names and product names mentioned in this manual are either registered trademarks or trademarks of their respective companies.

In some cases, trademark symbols such as [™] or [®] are not specified in this manual.

IB(NA)-0300249ENG-F(1806)MEE

MODEL: RD77-U-ADV-E

MODEL CODE: 1XB016

mitsubishi electric corporation

HEAD OFFICE : TOKYO BUILDING, 2-7-3 MARUNOUCHI, CHIYODA-KU, TOKYO 100-8310, JAPAN
NAGOYA WORKS : 1-14, YADA-MINAMI 5-CHOME, HIGASHI-KU, NAGOYA, JAPAN

When exported from Japan, this manual does not require application to the
Ministry of Economy, Trade and Industry for service transaction permission.

Specifications subject to change without notice.